

# Chelan County PUD



**Transmission & Distribution**

# Material Stock Catalog





## New Material Evaluation Procedures

Originator: DSmith      Date: 5/10/2007

Approval: R Phillips      Date: 4/25/2012

Page 1 of 4

Revision: Updated contact info

STD Committee: 4/25/2012

### 1. New Material Evaluation

1.1. Recognizing that new materials may provide improvement in design, construction, and maintenance for more cost effective construction, the District will evaluate such materials so that their use can be properly implemented and determined if they meet District Standards.

### 2. Scope

2.1. The Material Evaluation procedures outlined herein are applicable to all new materials submitted for consideration to the District for use in T&D construction and maintenance projects.

2.2. New materials are those, which have never been used or have been used on a limited basis without sufficient documentation or performance evaluation, except those specified on special contract documents.

### 3. Standards Committee

3.1. The Standards Engineer is responsible for administering this policy through the T&D Standards Committee. The Standards Committee is comprised of representative of the following areas.

- Engineering Standards
- Customer Service Engineering
- T&D Warehousing
- Purchasing District
- Electric Shop
- T&D Operations Supervisors
- T&D Journeyman Linemen
- Transmission, Substation or Distribution Engineers

### 4. Procedure

4.1. The Standards Department has been charged with the responsibility of coordinating the evaluations of new materials. The request for evaluation may be made by contractors, manufacturers, suppliers, consultants or District personnel, hereinafter referred to as the vendor.

4.2. The vendor is required to supply requisite information demonstrating the properties and performance of the material. At a minimum, the submission shall include the following:



## New Material Evaluation Procedures

Originator: DSmith      Date: 5/10/2007

Approval: R Phillips      Date: 4/25/2012

Page 2 of 4

Revision: Updated contact info

STD Committee: 4/25/2012

4.2.1. One copy of the completed form "T & D Material Evaluation" located on the last page of this document.

4.2.2. Pertinent technical data and test results which support use of the material and a statement identifying the uses and the cost benefit versus alternate materials.

4.2.3. If there are safety considerations or other restrictions or limitations on the use of the material, they should be stated and supplied also.

4.2.4. Additionally, if the material is a material developed through engineering design, the engineering calculations should be submitted.

4.2.5. Any additional information, material brochures, testing reports, etc., that you feel is pertinent to the evaluation of your material/procedure

4.2.6. Please do not submit any samples at this time. Should field or laboratory testing be needed you will be contacted and the samples requested.

### 4.3. Initial Evaluation

4.3.1. The submission will be reviewed by the T & D Standards Engineer. Materials not considered acceptable for further evaluation will be rejected at this point without further evaluation and the vendor so notified. Materials with questionable benefit or limited application by the District will be put on hold and the vendor so notified. Some materials require field-testing to fully understand their benefits. Should this be the case, the material/procedure will be moved to a "Long Range Evaluation Process" and its progress monitored.

4.3.2. All chemical products must be accompanied by a MSDS.

4.3.3. Our evaluation may include a review of technical and test data, visual inspection of the item, discussion in Standards Committee(s), field evaluation by electrical workers, inquiries to other utilities, and laboratory testing.

4.3.4. Some items require approval by our Environmental or Safety departments. The process may take several months.

4.3.5. Vendors will be informed of our decision at the end of the process.



## New Material Evaluation Procedures

Originator: DSmith      Date: 5/10/2007

Approval: R Phillips      Date: 4/25/2012

Page 3 of 4

Revision: Updated contact info

STD Committee: 4/25/2012

4.3.6. Materials with potential benefit and application will have the findings and recommendations presented to the T & D Standards Committee for action.

#### 4.4. Standards Committee Evaluation

4.4.1. The Committee shall further evaluate the information furnished and determine if any additional information, reference, sample material or material, testing or clarification is needed.

4.4.2. With complete information, the Committee shall evaluate and make recommendations as follows:

- APPROVED
- NOT APPROVED
- MATERIAL MEETS CURRENT SPECIFICATIONS
- NON - INTEREST or LIMITED USE ITEM

4.5. The vendor will be notified of the recommendation.

4.6. Acceptance of a material is in no way to be construed as a commitment to purchase, recommend, or specify a particular material.

### 5. Implementation

5.1. Upon request of the design personnel, the Standards Engineer will add the appropriate mfg part numbers to the existing Material Catalog Sheet or develop a new Material Catalog Sheet.

5.2. If appropriate, the Districts estimating system will be modified to allow inclusion of this material into T & D projects.

5.3. The use of the material is the responsibility of the project engineers.

### 6. Updating / Re-evaluating

6.1. As do several other area electric utilities, we generally do not re-evaluate items that have failed testing or have otherwise been rejected or removed from approval until a period of three (3) years has elapsed. Any exceptions to this policy are at our sole discretion.

6.2. The most current copies of all material specifications or catalog sheets are available on our web site.

6.3. You may always phone or e-mail to ask questions. The Standards Department tries to be helpful and fair, and we endeavor to approve as many qualified suppliers of products as is practical.





# New Material Evaluation Procedures

Originator: DSmith      Date: 5/10/2007

Approval: R Phillips      Date: 4/25/2012

Page 4 of 4

Revision: Updated contact info

STD Committee: 4/25/2012

## T & D Material Evaluation Form

Manufacturer \_\_\_\_\_ Mfr's. Cat. No. \_\_\_\_\_

Chelan County PUD Stock Number (if known) \_\_\_\_\_

Material Specification / Catalog Number (if known) \_\_\_\_\_

Applicable Industry Standards (ANSI, IEEE, NEMA, etc) \_\_\_\_\_

Description of item/application: \_\_\_\_\_

Current Users: (Attach additional sheets if necessary)

1. Contact Name \_\_\_\_\_ Phone Number: \_\_\_\_\_ Utility: \_\_\_\_\_

2. Contact Name \_\_\_\_\_ Phone Number: \_\_\_\_\_ Utility: \_\_\_\_\_

Material Safety Data Sheet Required and Attached \_\_\_\_\_

Estimated price \$ \_\_\_\_\_ per \_\_\_\_\_ Usual delivery time \_\_\_\_\_

Manufacturer's Representative: Name \_\_\_\_\_

(You may attach business card) Firm \_\_\_\_\_

Address: \_\_\_\_\_

Tel \_\_\_\_\_

Fax \_\_\_\_\_

e-mail \_\_\_\_\_

*This portion for Chelan County PUD use only*

Date Received \_\_\_\_\_ Date to field reviewer \_\_\_\_\_

Comments \_\_\_\_\_

Date review completed \_\_\_\_\_ Reviewer Initials: \_\_\_\_\_

Approved? Yes \_\_\_ No \_\_\_ by Standards.

Additional comments/reason if not approved \_\_\_\_\_

\_\_\_\_\_ Date mfr's. rep. notified: \_\_\_\_\_

**“OR EQUAL” DEFINITION**Originator:  
**DSmith**Date: **5/30/2007**Approval:  
**DSmith**Date: **5/30/2007**

Page 1 of 1

Revision: **NEW**STD Committee: **5/30/2007**

Application: This document defines the Approved Manufactures Part Numbers and “OR EQUAL” relationship.

**Definition of "Or Equal":**

1. **OR EQUAL** - Contractor-proposed substitution of specific materials or processes that are deemed by the District, in its sole discretion, to be equal in every material respect.
2. Offers of substitution for items described in the Contract Documents as "Or Equal" will be considered only upon the written request of the Contractor, and no requests for substitutions will be acknowledged or considered from suppliers, distributors, manufacturers, or Subcontractors or any other source. Requests for approval of substitution shall be made by following District Standards #0000.01 “New Material Evaluation Procedure”.
3. **NO PURCHASE SHALL BE MADE OR INSTALLATION PERFORMED BY CONTRACTOR WITHOUT APPROVAL OF THE DISTRICTS STANDARDS DEPARTMENT.**

**INSTRUCTIONS**  
**How to Use The Material Catalog**Originator: **DSmith**      Date: **7/6/2007**Approval: **DSmith**      Date: **7/6/2007**

Page 1 of 1

Revision: **NEW**

Approved

**1. Introduction**

1.1. The *Material Catalog* lists all items that District regularly stocks in warehouses and includes product descriptions organized by product categories and approved manufactures catalog numbers.

1.2. This information is updated on a daily basis and is used for Purchase Requisitions.

**2. Adobe Portable Document Format (PDF)**

The web site documents are published in the Adobe® Portable Document Format (PDF). You will need to download and install a free copy of Adobe Acrobat Reader to view the documents. Go to <http://www.adobe.com/products/acrobat/readstep2.html> if you have not already installed Acrobat Reader.

**3. Document Features:****3.1. Bookmark**

On the left side of the page is a section entitled “Bookmarks”. These bookmarks allow you to jump to a particular section or page easily.

**3.2. Search**

You can access the search function by mouse clicking on the binocular icon. Using this function, you can search for:

- Maximo Stock Number
- Manufactures Name
- Manufactures Catalog Number
- Any text or number

3.3. Printing: You can print all two hundred pages or any single page. The default is printing all pages so be careful.



# CONNECTORS

Originator: DSmith

Date: 7/9/2007

Approval: DSmith

Date: 7/9/2007

Page 1 of 1

Revision: **NEW**

Stds Committee Approval:  
**Approved**



# CONNECTORS

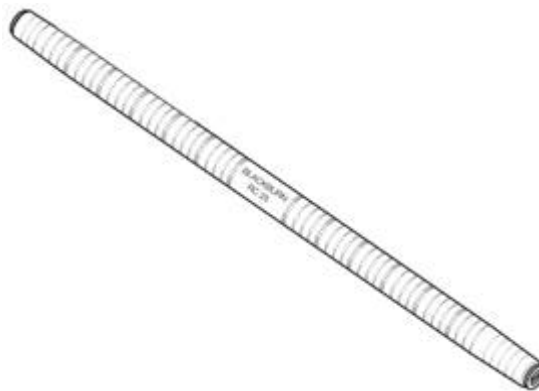
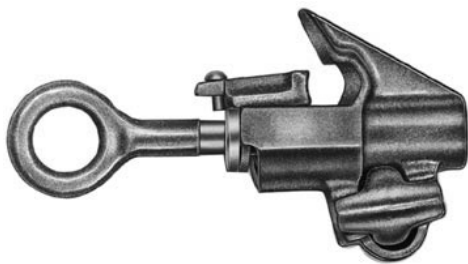



**Clamp, Cushion Grip, Suspension Shoe**

Originator: Randy Kono

Date: 10/13/11

Approval: J. Flader

Date: 5/14/13

Page 1 of 1

Revision: **Revised manufacturer Catalog #**

Stds Committee Approval:  
**Approved**

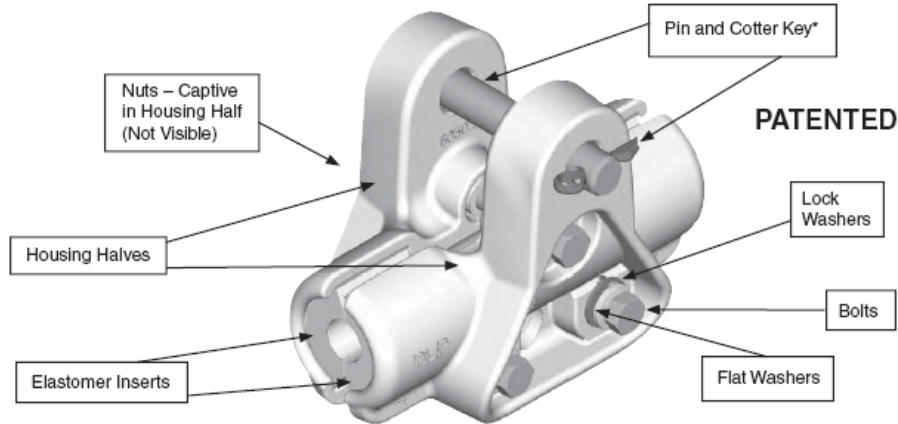

**Application:** CUSHION-GRIP Suspensions are intended for use on all aluminum based (AAC, ACSR) conductors, and are designed to reduce the static and dynamic stresses at the support point so that the conductor is protected against the effects of oscillations. The conductor is cushioned by field proven, integral elastomer inserts, which guard against abrasion, wear, and fatigue.

**Common Name:** CUSHION-GRIP Suspension Shoe

**Approved Manufacturers:** Preformed Line Products

PUD IDENTIFICATION		MANUFACTURER CATALOG NUMBER
Stock Description	Stock No.	Preformed Line Products
Clamp, Cushion Grip, Suspension, 336 ACSR 26/7, "Linnet"	014493	CGS-1096
Clamp, Cushion Grip, Suspension, 477 ACSR 26/7, "Hawk"	014493	CGS-1096
Clamp, Cushion Grip, Suspension, 636 AAC 37 Strand, "Orchid"	014492	CGS-1097
Clamp, Cushion Grip, Suspension, 636 ACSR 26/7, "Grosbeak"	014492	CGS-1097
Clamp, Cushion Grip, Suspension, 795 ACSR 26/7, "Drake"	014492	CGS-1097
Clamp, Cushion Grip, Suspension, 954 AAC 37 Strand, "Magnolia"	014492	CGS-1097
Clamp, Cushion Grip, Suspension, 1272 ACSR 45/7, "Bittern"	014487	CGS-1098
Clamp, Cushion Grip, Suspension, 1780 ACSR 84/19, "Chukar"	014488	CGS-1121

**Notes:**

- The maximum line angle for a Cushion-Grip Suspension clamp is 30°
- The maximum vertical load on a Cushion-Grip Suspension clamp is 25,000#
- Rated for 125° C continuous operation



### Clamp, Cushion Grip, Trunnion

Originator: Randy Kono

Date: 10/13/11

Approval: J. Mitchell

Date: 06/07/12

Page 1 of 1

Revision: **Updated size range**

Stds Committee Approval:  
**Approved**

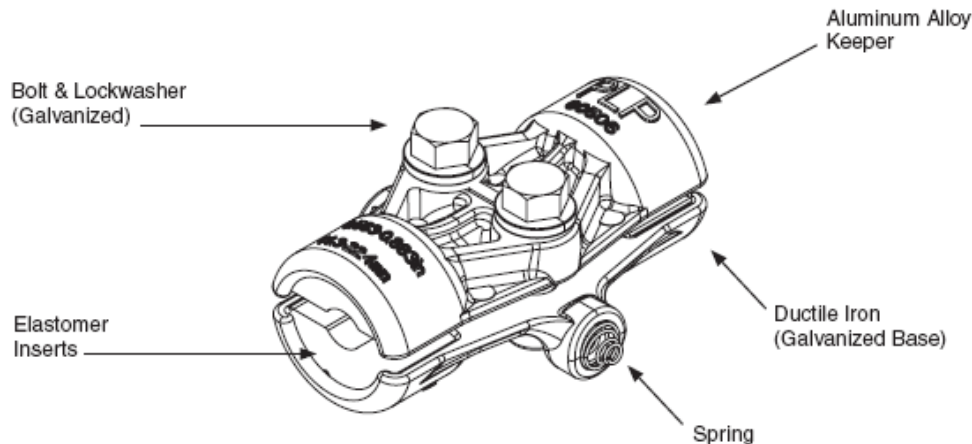

**Application:** The CUSHION-GRIP Support is intended for use on all aluminum based (AAC, ACSR) conductors, and is designed to reduce the static and dynamic stresses at the support point so that the conductor is protected against the effects of oscillations. The conductor is cushioned by field proven, integral elastomer inserts, which guard against abrasion, wear, and fatigue.

**Common Name:** CUSHION-GRIP Trunnion Clamp

**Approved Manufacturers:** Preformed Line Products

PUD IDENTIFICATION		MANUFACTURER CATALOG NUMBER
Stock Description	Stock No.	Preformed Line Products
Clamp, Cushion Grip, Support, AAC, ACSR Dia. .564" to .883"	014489	CGS-2101
Clamp, Cushion Grip, Support, AAC, ACSR Dia. .884" to 1.196"	014491	CGS-2102

**Notes:**

- The maximum line angle for a Cushion-Grip Suspension clamp is 30°
- The maximum load on a Cushion-Grip clamp is 5,000#
- Rated for 125° C continuous operation



**Clamp, Ground Rod**

Originator: DSmith

Date: 7/7/2006

Approval: DSmith

Date: 6/20/2007

Page 1 of 1

Revision: **NEW**

Stds Committee Approval:  
**Approved**

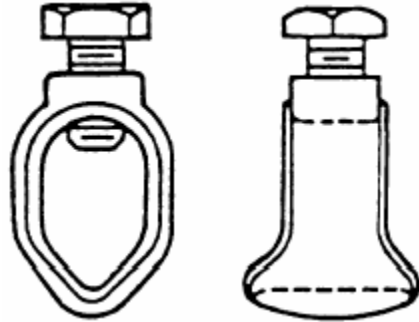

**Application:** Ground rod clamp is used to connect the pole ground wire to either copper jacketed or galvanized ground rod. Unit shall be capable of being torqued to 75 foot-lbs without breaking.

**Specification:** The ground rod clamp shall be suitable for connecting wire ranging from #6 to #2 AWG solid Copper to a ground rod.

**Material:** Ground rod clamp shall be manufactured from a cast bronze alloy. Ground rod clamp shall be supplied with a bolt manufactured from a non-ferrous metal.

**Bolt:** Shall have 9/16 inch hexagonal head

**Packaging and Marking:** Items shall be suitably packaged to prevent damage. The container shall be convenient for handling and storage. Manufacturer's name or symbol and catalog number shall be on each part and its packaging.

**Approved Manufacturers:**

PUD IDENTIFICATION		MANUFACTURER CATALOG NUMBER	
Stock Description	Stock No.	Eritech (ESP)	Wilcor
CLAMP GRND ROD - 5/8	014000	HDC58	WAG 5/8 HGR
CLAMP GRND ROD - 3/4	014040	HDC34	(T&B JAB34H)



**STIRRUPS, COMPRESSION HOTLINE**

Originator: DSmith

Date: 7/7/06

Approval: DSmith

Date: 6/20/2007

Page 1 of 1

Revision: **NEW**

Stds Committee Approval:  
**Approved**

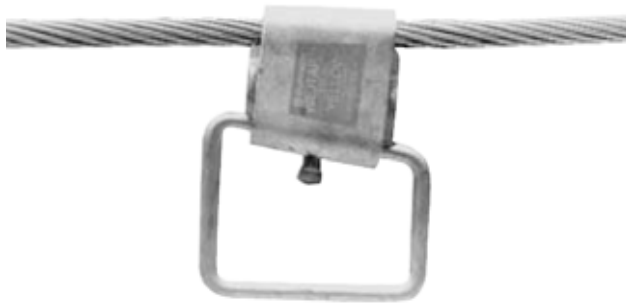

**Application:** WEJTAB Stirrups use an aluminum alloy wedge that is power-driven between the conductor and a "C" shaped tempered aluminum alloy spring-body. The stirrup is a smaller size conductor for connecting OH hotline taps and provide a quick, easy, and reliable method to protect overhead aluminum lines from arcing damage.

PUD IDENTIFICATION		MANUFACTURER CATALOG
Stock No.	Stock Description	Burndy
032005	STIRRUP, WEJTAP, #5, #4, #2 ACSR, AAC AND CU BAIL SIZE: #2 (RED) WITH POWER BOOSTER	WSS2PB
032010	STIRRUP, WEJTAP, CABLE 1, 1/0, 2/0 ACSR, AAC AND CU BAIL SIZE: #2 (BLUE) WITH POWER BOOSTER	WSM1PB
032015	STIRRUP, WEJTAP, 3/0-4/0 ACSR, AAC AND CU BAIL SIZE: #2 (BLUE) WITH POWER BOOSTER	WSM3PB
032020	STIRRUP, WEJTAP, 336 ACSR, AAC AND CU BAIL SIZE: 1/0 (YELLOW) WITH POWER BOOSTER	WSL1PB
032025	STIRRUP, WEJTAP, 556 ACSR, AAC AND CU BAIL SIZE: 2/0 (YELLOW) WITH POWER BOOSTER	WSL8PB
032030	STIRRUP, WEJTAP, 636 ACSR, AAC AND CU BAIL SIZE: #2/0 (WITH POWER BOOSTER)	WSL11PB
032035	STIRRUP, WEJTAP, 795 ACSR, AAC AND CU BAIL SIZE: #2/0 (WITH POWER BOOSTER)	WSL12PB





**HOTLINE TAP-OFF CLAMP, BRONZE**

Originator: DSmith

Date: 7/7/06

Approval: DSmith

Date: 6/20/2007

Page 1 of 1

Revision: **NEW**

Stds Committee Approval:  
**Approved**



**Application:** Used to connect equipment to small diameter copper primary conductor with a shotgun.

**Material:** Bronze alloy

**Packaging and Marking:** Items shall be suitably packaged to prevent damage. The container shall be convenient for handling and storage. Manufacturer's name or symbol and catalog number shall be on each part or (and) its packaging.

PUD IDENTIFICATION		MANUFACTURER CATALOG NUMBER
Stock No.	Stock Description	Hubbell
014100	CLAMP, HOT LINE, BRONZE, TAP AND MAIN: .128" -.414", #8SOL-#2/0(19) CU	GH100L



**CLAMPS, HOTLINE  
TAP & STIRRUPS, ALUMINUM**

Originator: DSmith

Date: 7/20/2006

Approval: DSmith

Date: 1/17/2008

Page 1 of 2

Revision: **Revised Main & Tap Sizes**

Stds Committee Approval:

**Approved**

Aluminum overhead hotline clamp

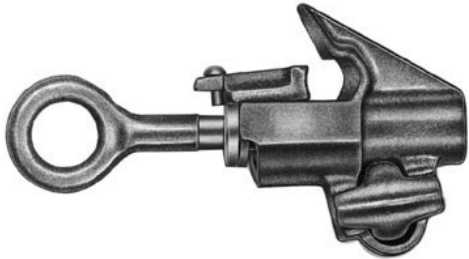

Aluminum overhead primary stirrup clamp



**Application:** For connecting Overhead taps to primary energized conductor with a lineman shotgun. Suitable for use on Aluminum, ACSR, and armor rod covered aluminum or ACSR conductor.

**Specification:**

Material: Body and Keeper – Aluminum Alloy – Tin Plated  
 Eyebolt – Bronze – Tin Plated  
 Eye stem – Bronze alloy, forged  
 Spring (on eye stem) Stainless Steel  
 The tap nut for the small & medium sizes shall be 9/16".  
 Each Item shall be individually packaged.

**Packaging and Marking:** Each Item shall be individually packaged to prevent damage. The container shall be convenient for handling and storage. Manufacturer's name or symbol and catalog number shall be on each part or (and) its packaging.

**Approved Manufacturers:**

PUD IDENTIFICATION		MANUFACTURER CATALOG NUMBER	
Stock Description	Stock No.	Hubbell	Mfg #2
014150	Clamp, Hot Line, Small, Tin Plated, 2/0 - #8, ACSR, AAC, Cu	S1520AGP	
014170	Clamp, Hot Line, Medium, Tin Plated Al, #6 - 397 AAC Main, #6-4/0 AAC, Cu, ACSR	AH4GP	
014190	Clamp, Hot Line, Large, Tin Plated Al, Main #4/0 – 636 Acc, ACSR, Tap #4-350 AAC, Cu, ACSR	S1540AGP	
014255	Clamp, Stirrup, Al, Hotline Connector, Single Clamp, #8sol-#2/0acsr Or AAC, Tap-Cu Loop #4	AHLS-022016-E	
014256	Clamp, Stirrup, Al, Hotline Connector, Dbl Clamp, #4/0-397acsr, #4/0-477 AAC, Tap-Cu Loop	AHLS-397021-E	
014257	Clamp, Stirrup, Al, Hotline Connector, Dbl Clamp, 397-954acsr, 450-1033.5 AAC Tap-Cu Loop	AHLS-954022-E	



**SPLIT BOLT**

Originator: DSmith

Date: 7/7/06

Approval: DSmith

Date: 6/20/2007

Page 1 of 1

Revision: **NEW**

Stds Committee Approval:  
**Approved**



**Application:** Used .to mechanically join two copper conductors together.

**Specifications:**

Material: Highly conductive copper alloy

Finish: Plain copper finish

**Packaging and Marking:** Items shall be suitably packaged to prevent damage. The container shall be convenient for handling and storage. Manufacturer's name or symbol and catalog number shall be on each part or (and) its packaging.

**Approved Manufacturers:**

PUD IDENTIFICATION		MANUFACTURER CATALOG NUMBER	
Stock No.	Stock Description	Burndy	ILSCO
015790	SPLIT BOLT, CU, MAIN/TAP #6SOL-#8SOL CU	KS-17	IK-8



**DEADEND CLAMPS,  
Bolted Straight-Line Spring-Loaded  
Side Opening**

Originator: D. Smith

Date: 8/29/06

Reviewed: D. Smith

Date: 8/11/2008

Page 1 of 1

Revisions: Changed Small Unit to accommodate 266ACSR, Removed Tin Plated Requirement due to sole source conflict.

Stds Committee Approval:  
**9/20/06**

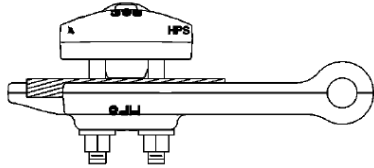

Figure 1 - Straight Line - Small

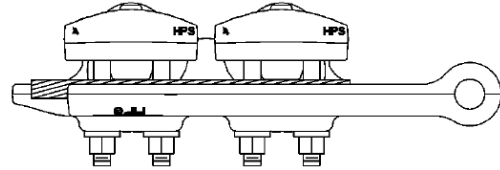
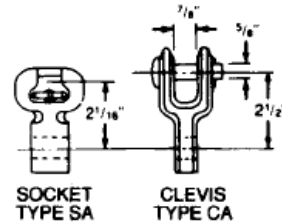

Figure 2 - Straight Line - Large



**Application:** Used for dead ending overhead AAC, AAAC, and ACSR conductor onto 15KV Insulators. May be used in conjunction with socket or clevis connection to the insulator (Must be ordered separate).  
**Not For Copper Conductor**

Recommended torque on 1/2" U-Bolts is 45 ft-lb.

**Specification:**

- Body & Keeper – 356-T6 Aluminum Alloy
- Hardware – Galvanized Steel
- Sockets & Clevises – Ductile iron, Galvanized (Ordered Separate)
- Spring and Cotter Pin – Stainless Steel
- Keeper is Spring Loaded

**Packaging and Marking:** Items shall be suitably packaged to prevent damage. The container shall be convenient for handling and storage. Manufacturer's name or symbol and catalog number shall be on each part or (and) its packaging.

**Approved Manufacturers:**

PUD IDENTIFICATION				MANUFACTURER CATALOG NUMBER	
Stock Description	Fig	Stock No.	Ult. Str (lbs)	MacLean	Hubbell
Clamp, Dead End, Straight Line, Spring Loaded Side Opening, <b>Small</b> #6ACSR/#4AAC To 336AAC	1	013810	8000	ASO-684-1-N	ASOD6841N
Clamp, Dead End, Straight Line, Spring Loaded Side Opening, <b>Large</b> 336ACSR/AAC To 900ACSR/954AAC	2	013880	12000	ASO-1160-2-N	ASOD11602N



**DEADEND CLAMPS,  
 Bolted Quadrant Style - Iron**

Originator: DSmith

Date: 6/20/2007

Approval: DSmith

Date: 6/20/2007

Page 1 of 1

Revision: **NEW**

Stds Committee Approval:  
**Approved**

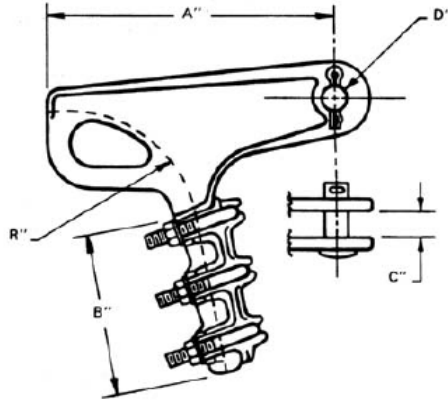

**Application:** Used for dead ending overhead ACSR conductor onto insulators.

**Specification:**

- Body & Keeper – 356-T6 Aluminum Alloy
- Hardware – Galvanized Steel
- Sockets & Clevises – Ductile iron, Galvanized
- Spring and Cotter Pin – Stainless Steel
- Keeper is Spring Loaded

**Packaging and Marking:** Items shall be suitably packaged to prevent damage. The container shall be convenient for handling and storage. Manufacturer's name or symbol and catalog number shall be on each part or (and) its packaging.

**Approved Manufacturers:**

PUD IDENTIFICATION		MANUFACTURER CATALOG NUMBER	
Stock Description	Stock No.	MacLean	Hubbell
CLAMP, DE, STRAIGHT LINE, IRON, #6-2/0ACSR, #6STR-4/0SOL CU	013820	SDE-46-F	MDE-46N
CLAMP, DE, STRAIGHT LINE, IRON, #2-336ACSR, #1-350AL	013830	ASO-684-2N	-----
CLAMP, DE, QUAD, IRON, .30"- .68"	013855	FQD-68-3-S	-----



**OVERHEAD SECONDARY SETSCREW BAR WITH STUD.**

Originator: DSmith

Date: 7/20/2006

Approval: DSmith

Date: 1/4/2008

Page 1 of 1

Revision: **NEW**

Stds Committee Approval:

**9/22/06**

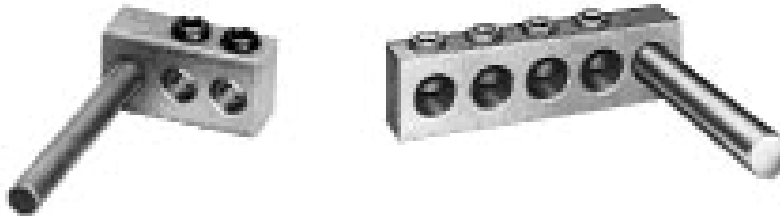

**Application:** Used to provide multiple taps from an overhead transformers eyebolt secondary terminal.

**Specification:**

Material: 6061-T6 aluminum alloy

Finish: Clear plated for low contact resistance

**Packaging and Marking:** Items shall be suitably packaged to prevent damage. The container shall be convenient for handling and storage. Manufacturer's name or symbol and catalog number shall be on each part or (and) its packaging.

**Approved Manufacturers:**

PUD IDENTIFICATION		MANUFACTURER CATALOG NUMBER		
Stock No.	Stock Description	HOMAC	CMC	UTILCO
040100	Overhead Secondary Setscrew Bar With Stud, 2 Pos, #6-250aac/Cu, 1/2"X4" Stud	ABP 240	NP2-250I	PTT 2-250
040101	Overhead Secondary Setscrew Bar With Stud, 4 Pos, #6-250aac/Cu, 1/2"X4" Stud	ABP 440	NP4-250I	PTT 4-250
040102	Overhead Secondary Setscrew Bar With Stud, 2 Pos, #12-350aac/Cu, 5/8"X4" Stud	ABP 2350	NP2-350I	PTT 2-350
040104	Overhead Secondary Setscrew Bar With Stud, 4 Pos, #12-350aac/Cu, 5/8"X4" Stud	ABP 4350	NP4-350I	PTT 4-350
040106	Overhead Secondary Setscrew Bar With Stud, 4 Pos, #6-500aac/Cu, 3/4"X4" Stud	ABP 4500	NP4-500I	PTT 4-500
040110	Overhead Secondary Setscrew Bar With Stud, 6 Pos, #12-350aac/Cu, 5/8"X4" Stud	ABP 6350	-----	-----



**SET SCREW AL BAR, ABOVE GRADE,  
FOR CU OR AL SECONDARY CABLE**

Originator: DSmith

Date: 1/4/2008

Approval: DSmith

Date: 1/4/2008

Page 1 of 1

Revision: Moved slip fit connectors to 1019.08

Stds Committee Approval:

**Approved**



**Application:** Used for providing multiple set screw terminations for Pole Mounted Transformers and other above grade Use.

**Specification:**

- Dual-rated connectors for aluminum or copper conductors
- Clear plated for low-contact resistance.
- Fully tested to ANSI C119.4 for Class 'A'

connectors.

- Supplied with radial-tipped set-screws.
- Connector fabricated from 6061-T6 aluminum alloy for conductivity and strength.
- Includes Oxide Inhibitor grease in all conductor holes.

**Packaging and Marking:** Each unit individually wrapped and labeled for ease of identification and cleanliness. Manufacturer's name or symbol and catalog number shall be on each part or (and) its packaging.

**Approved Manufacturers:**

PUD IDENTIFICATION		MANUFACTURER CATALOG NUMBER		
Item No.	Item Description	CMC	UTILCO	HOMAC
015322	CONNECTOR, SET SCREW AL BAR, ABOVE GRADE, 4 POSITION, #6-250 CU OR AL	UP4-250XB	PED-4-250 RH	ABC440
015223	CONNECTOR, SET SCREW AL BAR, ABOVE GRADE, 6 POSITION, #6-250 CU OR AL	UP6-250XB	PED-6-250 RH	ABC640
015324	CONNECTOR, SET SCREW AL BAR, ABOVE GRADE, 4 POSITION, #12-350 CU OR AL	UP4-350XB	PED-4-350 RH	ABC-4-350
015328	CONNECTOR, SET SCREW AL BAR, ABOVE GRADE, 6 POSITION, #12-350 CU OR AL	UP6-350XB	PED-6-350 RH	ABC6350



**TWO BOLT CONNECTOR**

Originator: DSmith

Date: 7/20/2006

Approval: DSmith

Date: 6/20/2007

Page 1 of 1

Revision: **NEW**

Stds Committee Approval:  
**Approved**



**Application:** Used to mechanically fasten two copper conductors together. Can be used on AAC or ACSR also.

**Specifications:**

Material: Utility Grade TIN Plated Bronze

**Packaging and Marking:** Items shall be suitably packaged to prevent damage. The container shall be convenient for handling and storage. Manufacturer's name or symbol and catalog number shall be on each part or (and) its packaging.

**Approved Manufacturers:**

PUD IDENTIFICATION		MANUFACTURER CATALOG NUMBER
Stock No.	Stock Description	Blackburn
015740	CONNECTOR, TWO BOLT, MAIN 800-600CU, TAP 800-#2CU	2B800PW
015750	CONNECTOR, TWO BOLT, MAIN 1000-750CU, TAP 1000-#2CU	2B1000PW





**Bolted Vise Type Tap  
 Connector for Copper Conductor**

Originator: DSmith

Date: 7/7/2006

Approval: J Mitchell

Date: 8/23/2011

Page 1 of 1

Revision: Removed Richards from #1 sol and #2 str

Stds Committee Approval: Approved



**Application:** Vise type connectors are used to tap copper conductors. For copper to copper connections-Splice, Loop dead-end or service entrance tap or grounding connections. This type of connector can be installed or removed "hot" with use of a special hot stick.

**Specification:**

Material: Body—Copper Alloy

Hardware—Stainless Steel or Silicon Bronze al

**Packaging and Marking:** Items shall be suitably packaged to prevent damage. The container shall be convenient for handling and storage. Manufacturer's name or symbol and catalog number shall be on each part or (and) its packaging.

**Approved Manufacturers:**

PUD IDENTIFICATION		MANUFACTURER CATALOG NUMBER		
Stock Description	Stock No.	Fargo	Richards	MacLean
Connector, Bronze Vise Type, Cu #6sol #8 Str	015600	GC-5006		
Connector, Bronze Vise Type Cu #4sol #4 Str	015610	GC-5004	VC5	BVC-4
Connector, Bronze Vise Type Cu #2sol	015630	GC-5002		
Connector, Bronze Vise Type Cu #1sol #2 Str	015640	GC-5002S		BVC-2S
Connector, Bronze Vise Type Cu #3/0sol #2/0	015660	GC-5020S	VC10S	BVC-20S
Connector, Bronze Vise Type Cu #4/0sol #4/0 Str	015670	GC-5040	VC12	BVC-040
Connector, Bronze Vise Type, 750kcm Cu	015730	GC-5075		



**CONNECTORS, BOLTED, ALUMINUM VISE TYPE**

Originator: DSmith

Date: 7/13/2006

Approval: DSmith

Date: 6/20/2007

Page 1 of 1

Revision: **NEW**

Stds Committee Approval:

9/22/06



**Application:** Recommended for aluminum or aluminum to copper distribution, service or tap connections. Units are supplied with a neoprene grommets for "hot" work. Grommet holds spacer bar in place during installation.

**Specification:**

Material: Body—Aluminum alloy

Spacer—Aluminum

Hardware—Stainless steel "SS" or Aluminum Alloy (std.)

**Packaging and Marking:** Items shall be suitably packaged to prevent damage. The container shall be convenient for handling and storage. Manufacturer's name or symbol and catalog number shall be on each part or (and) its packaging.

**Approved Manufacturers**

Stock No.	PUD IDENTIFICATION Stock Description	MANUFACTURER CATALOG NUMBER	
		Hubbell	Blackburn
015700	CONNECTOR, AL, VISE W/GROMMETS MAIN #6-336ACSR, TAP #6SOL 397AL OR CU	GA9401GL	
015702	CONNECTOR, AL, VISE MAIN AND TAP, #4-#6	GA9003GL	
015704	CONNECTOR, AL, VISE W/GROMMETS MAIN #6 1/0ACSR, TAP #6 #2/0STR OR CU	GA9020GLSS	
015710	CONNECTOR, TWO BOLT, AL, VISE W/GROMMETS MAIN #4/0-477ACSR, TAP 250-600 STR AL OR CUw/grommets, 2-bolt	GA-9520-GL	2B500PW



**BRAIDED JUMPER, TINNED COPPER**

Originator: DSmith

Date: 7/7/06

Approval: DSmith

Date: 6/20/2007

Page 1 of 1

Revision: **NEW**

Stds Committee Approval:  
**Approved**

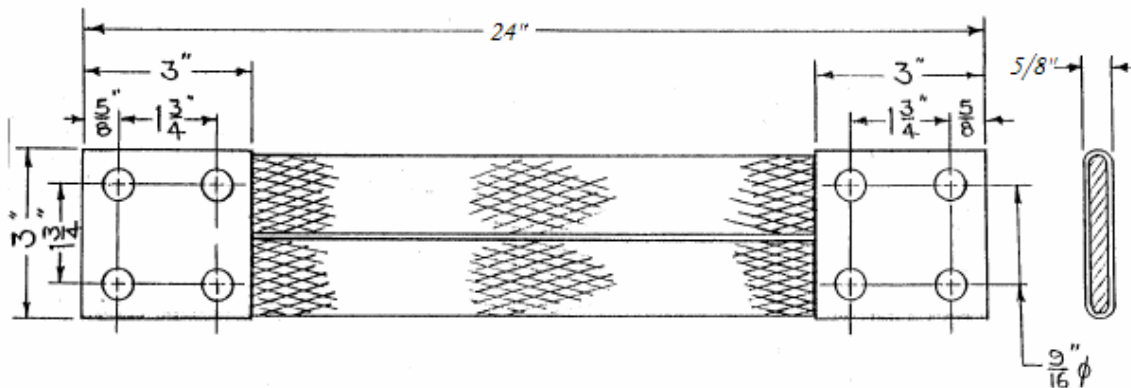

**Application:** Used to jumper between secondary nema connectors of overhead transformers for banking purposes. .

**Specifications:**

Material: Tinned Copper

**Packaging and Marking:** Items shall be suitably packaged to prevent damage. The container shall be convenient for handling and storage. Manufacturer's name or symbol and catalog number shall be on each part or (and) its packaging.

**Approved Manufacturers:**

PUD IDENTIFICATION		MANUFACTURER CATALOG NUMBER
Stock Description	Stock No.	SEFCOR
CONNECTOR, JUMPER, BRAIDED 24"L	022350	XB4N-1168-24



**BUSHING, OVERHEAD POLE-MOUNT  
 TRANSFORMER**

Originator: DSmith      Date: 7/7/06

Approval: DSmith      Date: 7/7/06

Page 1 of 1

Revision: **NEW**

Stds Committee Approval:  
**Approved**

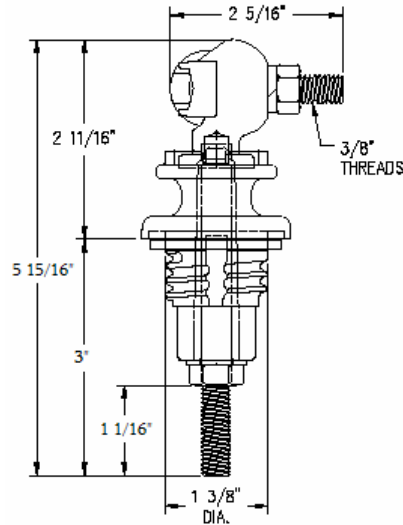

**Application:** Replacement single bolt clamp type bushing for overhead transformers. .

**Specifications:**

Material: Polymer insulator, polyester bushing

**Packaging and Marking:** Items shall be suitably packaged to prevent damage. The container shall be convenient for handling and storage. Manufacturer's name or symbol and catalog number shall be on each part or (and) its packaging.

**Approved Manufacturers:**

PUD IDENTIFICATION		MANUFACTURER CATALOG NUMBER
Stock Description	Stock No.	H-J Enterprises
INSULATOR, BUSHING, XFMR SECONDARY POLE MOUNT 25KVA REPLACEMENT	100461	AS1001-007



**SLEEVES, NICOPRESS**

Originator: DSmith

Date: 7/21/2006

Approval: DSmith

Date: 6/20/2007

Page 1 of 1

Revision: **NEW**

Stds Committee Approval:  
**Approved**



**Application:** Nicopress Splicing Sleeves are used to splice a wide range of conductors which include copper, copper covered steel, Copperweld copper, galvanized steel and Amerductor. Each sleeve is marked with catalog number, conductor size and installation tool groove.

**Packaging and Marking:** Items shall be suitably packaged to prevent damage. The container shall be convenient for handling and storage. Manufacturer's name or symbol and catalog number shall be on each part or (and) its packaging.

**Approved Manufacturers:**

	PUD IDENTIFICATION	MANUFACTURER CATALOG NUMBER
Stock No.	Stock Description	Joslyn Mfg
029560	SLEEVE, COMP, TENSION, #6 SOLID CU (NICO), LENGTH-2 1/4"	1-162J
029630	SLEEVE, COMP, TENSION, #8 SOLID CU (NICO), 2"	1-128J
029650	SLEEVE, COMP, TENSION, #4 SOL CU, (NICO), 2 1/2"	1-204P
029710	SLEEVE, COMP, TENSION, #2 SOL, #4 STR CU (NICO), 2 3/4"	1-258-X
029820	SLEEVE, COMP, TENSION, #2 STR, CU (NICO), 3", #2 STR CU	1-6A-P
030730	SLEEVE, COMP, #8A CU WELD, SPLIT	R1-8AP
030820	SLEEVE, COMP, TENSION, #6A CU WELD, (NICO), 5 1/2"	1-16A-P
030850	SLEEVE, COMP, #6A CU WELD, SPLIT, 4"	R1-6A-P
030890	SLEEVE, COMP, TENSION, 4A CU WELD, (NICO), 5 3/4", 4A CU WELD	1-4A-X
030910	SLEEVE, COMP, TENSION, #6 CRAPO, (NICO), 6 3/4", #6 CRAPO	5-203/3-S



**SLEEVES, COMPRESSION  
FULL TENSION**

Originator: DSmith      Date: 7/7/06

Approval: DSmith      Date: 7/7/06

Revision: **NEW**  
Spelling error

Stds Committee Approval:  
**Approved**



**Application:** Used to splice Overhead conductor under full tension.

**Ordering Description:** List requirements as needed to describe the properties of the item. If necessary, use blanks ( ) in description and add any of the following.

Dimensions:

Strength: Shall be capable of holding 90% of Conductor Strength

Material: Aluminum Alloy

**Packaging and Marking:** Items shall be suitably packaged to prevent damage. The container shall be convenient for handling and storage. Manufacturer's name or symbol and catalog number shall be on each part or (and) its packaging.

**Approved Manufacturers:**

PUD IDENTIFICATION		MANUFACTURER CATALOG NUMBER
Stock Description	Stock No.	Alcoa
SLEEVE, COMP, JUMPER, 336KCM ACSR	022200	5020.781
SLEEVE, COMP, JUMPER, 636KCM ACSR	022300	5027.106
SLEEVE, COMP, JUMPER, 336KCM AAC	029320	5076.688
SLEEVE, COMP, JUMPER, 350KCM AAC	029340	5076.719
SLEEVE, COMP, JUMPER, 477KCM AAC	029360	5020.812
SLEEVE, COMP, JUMPER, 4/0 ACSR	032980	5075.609
SLEEVE, COMP, JUMPER, 4/0 ACSR ANGLE	033000	975.2
SLEEVE, COMP, JUMPER, 795 ACSR	087400	5030.116



**SLEEVES, ACSR  
FULL TENSION COMPRESSION  
One Piece**

Originator: DSmith

Date: 11/13/06

Approval: DSmith

Date: 11/17/2010

Page 1 of 1

Revision: **NEW**

Stds Committee Approval:  
**Approved**

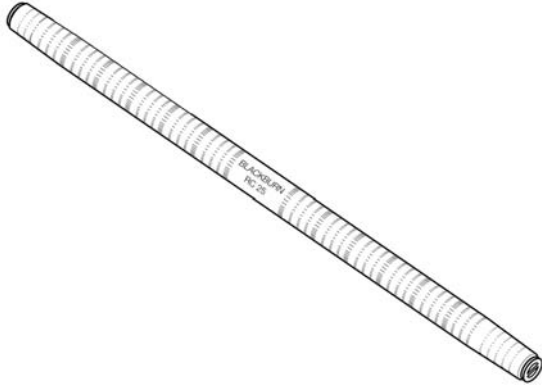

**Application:** One Piece Unit used to splice ACSR overhead conductor in full tension.

**Packaging and Marking:** Items shall be suitably packaged to prevent damage. The container shall be convenient for handling and storage. Manufacturer's name or symbol and catalog number shall be on each part or (and) its packaging.

**Specification:**

- o Have a positive center stop and tapered ends.
- o Installed with compression dies from Burndy or Kerney.
- o Prefilled with tension joint compound
- o Meets industry requirements for full tension splicing per EEI TDJ-162 (ANSI C119.4) All compression joints shall be designed for full tension use, achieving a minimum of 95% of the ASTM rated strength of the conductor on which they are used
- o Material: Aluminum

**Approved Manufacturers:**

PUD IDENTIFICATION		MANUFACTURER CATALOG NUMBER		
Stock Description	Stock No.	Burndy	Hubbell	Blackburn
SLEEVE, COMP, TENSION, AL, #6 ACSR	047842	YSS6RG2		
SLEEVE, COMP, TENSION, AL, #4 ACSR	029080	YDS4RL	FTR4	RC4BB
SLEEVE, COMP, TENSION, AL, #1/0 ACSR	030190	YDS25RL	FTR10	RC10
SLEEVE, COMP, TENSION, AL, #2/0 ACSR	030250	YDS26RL	FTR205	RC20
SLEEVE, COMP, TENSION, AL, #4/0 ACSR	030311	YDS28RLY	FTR40	RC40



**SLEEVES, SERVICE WIRE NEUTRAL SPLICE  
 PARTIAL TENSION COMPRESSION  
 ONE PIECE**

Originator: DSmith

Date: 11/13/06

Approval: DSmith

Date: 12/2/2008

Page 1 of 1

Revision: Moved 030160 to 1019.11 category

Stds Committee Approval:  
**Approved**

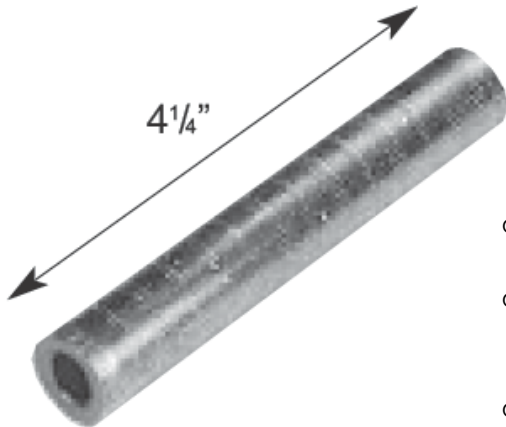

**Application:** One Piece Unit used to splice Service Wire Neutral overhead conductor at partial tension. Not For Copper to Copper

**Specification:**

- Has a positive center stop to facilitate equal crimping and is installed with compression dies from Burndy or Kerney.
- Prefilled with electrical joint compound. Marked with catalog number, conductor size and die reference. Meets performance requirements of ANSI C119.4.
- **Material:** Aluminum
- 

**Packaging and Marking:** Items shall be suitably packaged to prevent damage. The container shall be convenient for handling and storage. Manufacturer's name or symbol and catalog number shall be on each part or/and its packaging.

○

Stock No.	PUD IDENTIFICATION Stock Description	MANUFACTURER CATALOG NUMBER				
		Hubbell	Burndy	HOMAC	CMC	Kearney
029090	Sleeve, Comp, Partial Tension, Al, #4 ACSR Neutral Messenger, Orange - Orange	VANS-4-4		SNG44	NCL4	30009
029140	Sleeve, Comp, Tension, Al, #2 ACSR Neutral Messenger, Red - Red	VANS-1-1		SNG22	NCL2	30010
030190	Sleeve, Comp, Partial Tension, Al, #1/0 ACSR Neutral Messenger, Yellow - Yellow	VANS 1/0-1/0	YSD25R25R	SNG 00	NCL1/0	30715
030250	Sleeve, Comp, Partial Tension, Al, #2/0 ACSR Neutral Messenger, Gray - Gray	VAUS 2020	YSD26R26R	-	-	36060
029280	Sleeve, Comp, Partial Tension, Al, #4/0 ACSR Neutral Messenger, Pink - Pink	VAUS 4040	YCS28A	-	-	49528





**Sleeve, Insulated  
Nontension Service  
"Firecrackers"**

Originator: dsmith

Date: 7/17/2006

Approval: dsmith

Date: 7/25/2007

Page 1 of 1

Revision: **Revised – Added new items.**

Stds Committee Approval:

**Approved**



**Application**

Service entrance sleeves are for any combination of copper, aluminum, ACSR, compressed and compact conductors, in non-tension use. Pre-filled with PENETROX joint compound and capped. Sleeves shall have a center divider to prevent migration of moisture from the service to the service entrance conductors.

**Common Name:** Firecrackers

**Details:**

Stk #	Color Code A-B	Conductor Range A	Conductor Range B	Die
047840	Blue - Blue	6 ACSR, 6 STR, 4 Solid	6 ACSR, 6 STR, 4 Solid	5/8
047850	Orange-Orange	4 ACSR, 4 STR., 2 Sol.	4 ACSR, 4 STR., 2 Sol.	5/8
047860	Red-Red	2 ACSR, 1-2 STR.	2 ACSR, 1-2 STR.	5/8
047880	Red-Orange	2 ACSR, 1-2 STR.	4 ACSR, 3-4 STR., 2 SOL.	5/8
047885	Red-Yellow	2 ACSR, 1-2 STR.	1/0 ACSR, 2/0 STR., 1/0 STR.	5/8
047875	Yellow-Yellow	1/0 ACSR, 2/0 STR., 1/0 STR.	1/0 ACSR, 2/0 STR., 1/0 STR.	840
047870	Grey-Grey	2/0 ACSR, 2/0 STR., 3/0 STR.	2/0 ACSR, 2/0 STR., 3/0 STR.	840
047890	Pink-Gray	4/0 ACSR , 4/0 STR.	2/0 ACSR, 2/0 STR., 3/0 STR.	840
047895	Pink-Pink	4/0 ACSR , 4/0 STR.	4/0 ACSR , 4/0 STR.	840

**Approved Manufacturers:**

Stock No.	Maximo Description	Manufacturer Catalog Number		
		Blackburn	Burndy	Homac
047840	Sleeve, Insulated Nontension Service, #6ACSR, #6STR, #4Sol <b>Blue – Blue</b>	ICS64-1	ES4W4W	UBB66
047850	Sleeve, Insulated Nontension Service, #4ACSR, #4STR, #2Solid, <b>Orange - Orange</b>	ICS68-1	ES2W2W	UOO44
047860	Sleeve, Insulated Nontension Service, #2ACSR, #2STR <b>Red – Red</b>	ICS73-1	ES2R2R	URR22
047880	Sleeve, Insulated Nontension Service, #2ACSR To #4ACSR, <b>Red-Orange</b>	ICS72-1	ES2R2W	U1N24
047885	Sleeve, Insulated Nontension Service, #2ACSR To 1/0ACSR, <b>Red-Yellow</b>	ICS77-1	ES25R2R	U1N102
047875	Sleeve, Insulated Nontension Service, 1/0ACSR, 1/0STR <b>Yellow - Yellow</b>	IKL36	ES25R25R	U1N1010
047870	Sleeve, Insulated Nontension Service, #2/0ACSR, #2/0 STR <b>Grey – Gray</b>	IKL54	NONE	X1N2020
047890	Sleeve, Insulated Nontension Service, #4/0ACSR To #2/0ACSR, <b>Pink-Grey</b>	IKL67	NONE	X1N4020
047895	Sleeve, Insulated Nontension Service, #4/0ACSR, #4/0STR <b>Pink-Pink</b>	IKL69	NONE	X1N4040



**Conductors, Compression,  
Tap, H-Type Wide Range  
for AL/AL or AL/CU**

Originator: DSmith

Date: 6/21/2007

Approval: DSmith

Date: 10/1/2008

Page 1 of 1

Revision: added Burndy YHN600 for #015550 & Changed description of 015560

Stds Committee: **Approved**

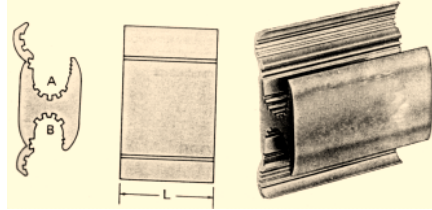

**Application:** The "H" type wide range compression connector is used to make tap connections at secondary voltages. The connector can be used for joining aluminum or copper using "O" or "D" dies in standard tools.

**Ordering Description:** Compression tap connector, wide range for aluminum and/or copper conductor. Stranded wire range (A groove) to (B groove).

**Strength:** Shall Connectors shall meet Class 2 Requirements of ANSI Standard C119.4, latest revision.

**Material:** Connectors shall be made of E.C. grade aluminum and be prefilled with approved inhibitor. Interior surfaces of conductor grooves shall be serrated to grip conductors.

**Compression Dies:** Connectors shall be suitable for installation using 5/8 BG (or) "O" or "D" dies.

**Packaging and Marking:** Connectors shall be individually packaged in a container suitable for easy handling and storage. Each container shall be marked with manufacturer's name, catalog number, wire ranges and die codes. The universal code number shall appear in "Shadow Form" on the face of the box or on the box flap.

**Approved Manufacturers:**

PUD IDENTIFICATION		MANUFACTURERS CATALOG NUMBER			
Stock Description	Stock No	Burndy	Cooper	Utilco	Homac
HTAP, COMP #1-#6 ACSR/AL/CU	015400	YHO100	506-82	HT1	OB44
HTAP, COMP #2 ACSR/AL/CU	015405	YHO150	508-82	HT2	OB101
HTAP, COMP #3 ACSR/AL/CU	015410	YHD200	502-82		DB202
HTAP, COMP #4 ACSR/AL/CU	015420	YHD300	504-82	HT4	DB2020
HTAP, COMP #5 ACSR/AL/CU	015500	YHD250	503-82	HT5	DB404
HTAP, COMP #6 ACSR/AL/CU	015440	YP28U26	-----		
HTAP, COMP #7 ACSR/AL/CU	015510	YHD400	507-82	HT7	DB4040
HTAP, COMP #4/0-#400 MAIN, #4/0-#2/0 TAP	015520	YHN450	-----	-----	-----
HTAP, COMP #4/0-#500 MAIN, #6-#2/0 TAP	015530	YHN500	-----	-----	-----
HTAP, COMP #250-#500 MAIN, #3/0-#4/0 TAP	015540	YHN550	-----	-----	-----
HTAP, COMP #266-#500 MAIN, #266-#350 TAP	015550	YHN600	-----	-----	-----
HTAP, COMP #3/0-#4/0 MAIN, #2/0 SOL/STR TAP	015505	YHD350	505-82	HT6	DB4020
HTAP, COMP 556-795ACSR MAIN, 1/0-336ACSR TAP	015560	YHR800	-----	-----	-----



**CRIMPIT, COMPRESSION  
COPPER "C-TAPS"  
FOR COPPER**

Originator: DSmith

Date: 10/8/2007

Approval: DSmith

Date: 10/8/2007

Page 1 of 1

Revision:

Stds Committee: **Approved**



**Application:** The "C" Type copper CRIMPIT™ connector is a range-taking C shape compression connector for making tap or parallel copper connections from #12 sol. to 4/0 strand conductor. It's primary usage is for connecting copper neutral busses.

**Packaging and Marking:** Connectors shall be individually packaged in a container suitable for easy handling and storage. Each container shall be marked with manufacturer's name, catalog number, wire ranges and die codes. The universal code number shall appear in "Shadow Form" on the face of the box or on the box flap.

**Approved Manufacturers:**

PUD IDENTIFICATION		MANUFACTURERS CATALOG NUMBER			
Stock Description	Stock No	Burndy	Cooper	Utilco	Homac
CRIMPIT, COPPER "C-TAPS", #2 SOL/STR CU MAIN, #2 SOL/STR CU TAP	015580	YC2C2	-----	-----	-----
CRIMPIT, COPPER "C-TAPS", #6SOL-#4STR CU MAIN, #6SOL/STR CU TAP	015590	YC4C6	-----	-----	-----
CRIMPIT, COPPER "C-TAPS", #6SOL-#4STR CU MAIN, #4SOL/STR CU TAP	015595	YC4C4	-----	-----	-----



**TAP, TEE, CABLE TO 4 HOLE PAD  
Transmission**

Originator: DSmith

Date: 7/7/2006

Approval: DSmith

Date: 6/22/2007

Page 1 of 1

Revision: **NEW**

Stds Committee Approval:  
**Approved**

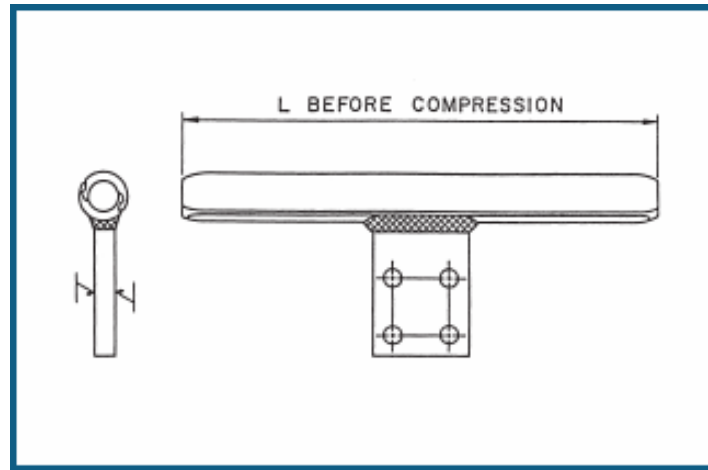

**Application:** Tee Tap is a permanent or temporary drop specifically designed for ACSR and ACSS/TW conductors. It is fabricated from a specially tempered aluminum that will transfer elevated current and dissipate increased heat more efficiently.

**Packaging and Marking:** Items shall be suitably packaged to prevent damage. The container shall be convenient for handling and storage. Manufacturer's name or symbol and catalog number shall be on each part or (and) its packaging.

**Approved Manufacturers:**

PUD IDENTIFICATION		MANUFACTURER CATALOG NUMBER
Stock No.	Stock Description	ALCOA
087650	Tap, Tee, Cable To 4 Hole Pad, 4/0 ACSR	#5375
087660	Tap, Tee, Cable To 4 Hole Pad, 336.4 ACSR	#5320.3
087665	Tap, Tee, Cable To 4 Hole Pad, 336.4 AAC	#5376
087670	Tap, Tee, Cable To 4 Hole Pad, 636 ACSR	#5327.3
087675	Tap, Tee, Cable To 4 Hole Pad, 636 AAC	#5324.3
087680	Tap, Tee, Cable To 4 Hole Pad, 795 ACSR	#5330.3



**SPLICE OH, ACSR  
FULL TENSION PREFORMED**

Originator: DSmith

Date: 11/13/06

Approval: DSmith

Date: 8/29/2007

Page 1 of 1

Revision: **NEW**

Stds Committee Approval:  
**Approved**



**Application:** This is a three piece component system designed to splice ACSR overhead conductor in full tension. Rated holding strengths are 100% of the conductor rated breaking strength.

**Packaging and Marking:** Items shall be suitably packaged to prevent damage. The container shall be convenient for handling and storage. Manufacturer's name or symbol and catalog number shall be on each part or (and) its packaging.

**Approved Manufacturers:**

PUD IDENTIFICATION		MANUFACTURER CATALOG NUMBER	
Stock No.	Stock Description	PREFORMED	
031420	SPLICE, FULL TENSION PREFORMED, #4ACSR 6/1, (CORE BLACK, OUTER ORANGE)	FTS-5100	
031580	SPLICE, FULL TENSION PREFORMED, 795ACSR 26/7, (CORE BLACK, FILLER BLACK, OUTER ORANGE)	FTS-5122	



**SLEEVES, SPLIT REPAIR, ACSR  
Transmission**

Originator: DSmith

Date: 7/21/2006

Approval: DSmith

Date: 6/22/2007

Page 1 of 1

Revision: **NEW**

Stds Committee Approval:  
**Approved**

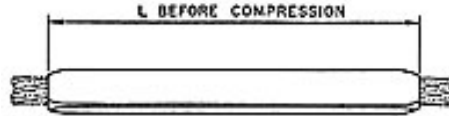

**Application:** The ALCOA 5200 Series Repair Sleeve is designed for ACSR conductors. The repair sleeve incorporates an improved design of interlocking extrusions, providing a permanent grip on the conductor when compressed. The repair sleeve will restore 95% of the rated strength of the conductor with up to one-third of the outer aluminum strands damaged.

**Packaging and Marking:** Items shall be suitably packaged to prevent damage. The container shall be convenient for handling and storage. Manufacturer's name or symbol and catalog number shall be on each part or (and) its packaging.

**Approved Manufacturers:**

PUD IDENTIFICATION		MANUFACTURER CATALOG NUMBER
Stock No.	Stock Description	ALCOA
029390	SLEEVE, COMP, SPLIT REPAIR, 477KCM ACSR TO 636KCM ACSR 24AH DIE	5224.3
030400	SLEEVE, COMP, SPLIT REPAIR, #4/0, 74AH DIE	5274.1
030490	SLEEVE, COMP, SPLIT REPAIR, 266KCM, 20AH DIE	5276
030510	SLEEVE, COMP, SPLIT REPAIR, 336KCM, 20AH DIE	5220.3
030580	SLEEVE, COMP, SPLIT REPAIR, 636KCM, 30AH DIE	5337.3
087410	SLEEVE, COMP, SPLIT REPAIR, 477-795KCM, 30AH DIE	5230.3
087460	SLEEVE, COMP, SPLIT REPAIR, 1272KCM (45/7), 36AH DIE	5236.3



**SLEEVE, COMPRESSION/TENSION, AAC  
Transmission**

Originator: DSmith

Date: 7/7/06

Approval: DSmith

Date: 6/22/2007

Page 1 of 1

Revision: **NEW**

Stds Committee Approval:  
**Approved**



**Application:** The 7000 Series Compression Joint is specifically designed for AAC conductors. The aluminum joint is fabricated from Alcoa seamless drawn aluminum. All compression joints are designed for full tension use, achieving a minimum of 95% of the ASTM rated strength of the conductor on which they are used.

For die size sections 30AH and above, the end tapers of the compression portions of all compression accessories are supplied with a high voltage finish.

**Packaging and Marking:** Items shall be suitably packaged to prevent damage. The container shall be convenient for handling and storage. Manufacturer's name or symbol and catalog number shall be on each part or (and) its packaging.

**Approved Manufacturers:**

PUD IDENTIFICATION		MANUFACTURER CATALOG NUMBER
Stock Description	Stock No.	ALCOA
SLEEVE, COMP, TENSION 336KCM AAC19STR, 76AH DIE	029310	7076.688
SLEEVE, COMP, TENSION 477KCM AAC19STR, 20AH DIE	029380	7020.812
SLEEVE, COMP, TENSION 636KCM AAC 37STR, 24AH DIE	029400	7024.969
SLEEVE, COMP, TENSION 954KCM AAC 37STR, 30AH DIE	029460	7030.122





**SLEEVES, ACSR  
 ALCOA FULL TENSION  
 Transmission**

Originator: DSmith

Date: 3/13/2007

Approval: DSmith

Date: 10/22/2014

Page 1 of 1

Revision: **NEW**

Std's Committee Approval:  
**Approved**

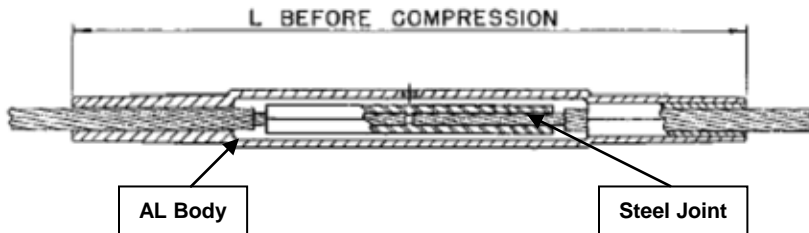

**Application:** Used to splice ACSR overhead conductor in full tension.

**Specification:** These compression joint assembly are two piece units consisting of an aluminum body with a separate steel core and shall be specifically designed for ACSR conductors. The aluminum body shall be fabricated from seamless drawn aluminum. All compression joints shall be designed for full tension use, achieving a minimum of 95% of the ASTM rated strength of the conductor on which they are used.

**Packaging and Marking:** Items shall be suitably packaged to prevent damage. The container shall be convenient for handling and storage. Manufacturer's name or symbol and catalog number shall be on each part or (and) its packaging.

**Approved Manufacturers:**

PUD IDENTIFICATION		MANUF CATALOG NUMBER	
Stock No.	Stock Description	ALCOA	T & B
030340	Sleeve, Comp, Tension, AL BODY, 4/0 (6/1) ACSR, 75AH DIE	8075.609	
030370	Sleeve, Comp, Tension, STL JOINT, 4/0 (6/1), 75SH DIE	4075.228	
030430	Sleeve, Comp, Tension, AL BODY, 266(26/7), 76AH DIE	8076.688	
030460	Sleeve, Comp, Tension, STL JOINT, 266(26/7), 76SH DIE	4076.246	
030520	Sleeve, Comp, Tension, AL BODY, 336(26/7), 20AH DIE	8020.781	
030530	Sleeve, Comp, Tension, STL JOINT, 336(26/7), 10SH DIE	4010.277	
030540	Sleeve, Comp, Tension, STL JOINT, 336(30/7), 10SH DIE	4010.332	
030550	Sleeve, Comp, Tension, AL BODY, 636(26/7), 27AH DIE	8027.106	
030640	Sleeve, Comp, Tension, STL JOINT, 636(26/7), 12SH DIE	4012.386	
087180	Sleeve, Comp, Tension, AL BODY, 397(26/7), 20AH DIE	8029.844	
087200	Sleeve, Comp, Tension, STL JOINT, 397(26/7), 10SH DIE	4010.301	
087240	Sleeve, Comp, Tension, AL BODY, 477(26/7), 24AH DIE	8024.938	
087260	Sleeve, Comp, Tension, STL JOINT, 477(26/7), 12SH DIE	4012.332	
087360	Sleeve, Comp, Tension, AL BODY, 795(26/7), 30AH DIE	8030.116	
087420	Sleeve, Comp, Tension, AL BODY, 1272(45/7), 36AH DIE	8036.147	
087440	Sleeve, Comp, Tension, STL JOINT, 1272(45/7), 16SH DIE	4012.351	





**TERMINAL PAD, COMPRESSION**

Originator: DSmith

Date:6/21/2007

Approval: DSmith

Date:10/22/2008

Page 1 of 2

Revision: Updated Mfg Part Number

Stds Committee Approval:  
**Approved**



**Application:** Used to transition between conductor and NEMA 1, 2 or 4 hole pads. Due to Compression tooling restrictions only use Hubbell/Anderson lugs for the larger sizes. Suitable for AAC, ACSR, or Copper Conductor as shown.

**Specification:** Material: Aluminum, tinned aluminum or Bronze

**Packaging and Marking:** Items shall be suitably packaged to prevent damage. The container shall be convenient for handling and storage. Manufacturer's name or symbol and catalog number shall be on each part or (and) its packaging.

Stock No.	Maximo Stock Description	MANUFACTURER CATALOG NUMBER
033224	Terminal Lug, Comp, 4/0 2-Hole 1/2", Bronze	AMP, #276762-1
050360	Terminal Lug, Comp, #2, Tin Plated Al, 1-Hole, 3/8" Bolt Size, With Oxide Inhibitor	Homac AL 2-38
050370	Terminal Lug, Comp, #2 Tin Plated Al, 2-Hole, 1/2" Bolt, With Oxide Inhibitor	Hubbell VAUL-1-12BN-TP
050380	Terminal Lug, Comp, #1/0, Tin Plated Al, 2-Hole, 1/2" Bolt, With Oxide Inhibitor	Hubbell VAUL-1/0-12BN-TP
050390	Terminal Lug, Comp, #2/0, Tin Plated Al, 2-Hole, 1/2" Bolt, With Oxide Inhibitor	Hubbell VAUL-2/0-12BN-TP
050420	Terminal Lug, Comp, #4/0, Tin Plated Al, 2-Hole, 1/2" Bolt, With Oxide Inhibitor	Hubbell VAUL-4/0-12BN-TP
050422	Terminal Lug, 4/0 Cu, Two Hole NEMA, Copper	Burndy YGHA28-2N
050424	Terminal Lug, 4/0 Cu, Two Hole NEMA, Tin Plated Aluminum	Burndy YAV282NFXB



**TERMINAL PAD, COMPRESSION**

Originator: DSmith

Date:6/27/2014

Approval: J. Mitchell

Date:6/27/2014

Revision: Updated description for 050460r

Stds Committee Approval:

**Approved**

Stock No.	Maximo Stock Description	MANUFACTURER CATALOG NUMBER
050440	Terminal Lug, Comp, 336kcm, Tin Plated Al, 2-Hole, 1/2" Bolt, With Oxide Inhibitor	Hubbell VAUL-350-12BN-TP
050445	Terminal Lug, Comp, 336.4 ACSR, Tin Plated Al, 2-Hole, All Purpose	PENN-UNION #KVL-RO33D1
050450	Terminal Lug, Comp, 500kcm, Tin Plated Al, 2-Hole, 1/2" Bolt, With Oxide Inhibitor	Hubbell VAUL-500-12BN-TP
050451	Terminal Lug, Comp, 500kcm, Tin Plated Al, 2-Hole	Burndy #YAK34A2G2
050452	Terminal Lug, Comp, 500kcm, Tin Plated Al, 2-Hole	Burndy #YAK34A2G1
050460	Terminal Lug, Comp, 750kcm, Tin Plated Al, 2-Hole	Hubbell VAUL-750-12BN-TP
050480	Terminal Lug, Comp, 750, Tin Plated Al, 2-Hole	Homac 750 NTN
050485	Terminal Lug, Comp, 750, Tin Plated Al, 2-Hole	Hubbell ALCF-800B
050490	Terminal Lug, Comp, 750kcm To 1000kcm, Tin Plated Al, 2-Hole, 1/2" Bolt, With Oxide Inhibitor	Hubbell VAUL-1000-12BN-TP
050495	Terminal Lug, Comp, 750kcm to 1000kcm Tin Plated Al, 4-Hole, Short Barrel, 1/2" Bolt, With Oxide Inhibitor	CCLS-1216C



**Deadend, Compression, Jumper Terminals, 15°,  
ACSR & AAC Conductors**

Originator: Jennifer Smith

Date: 10/17/2008

Approval: Jennifer Smith

Date: 10/17/2008

Page 1 of 1

Revision: **NEW**

Stds Committee Approval:  
**Approved**

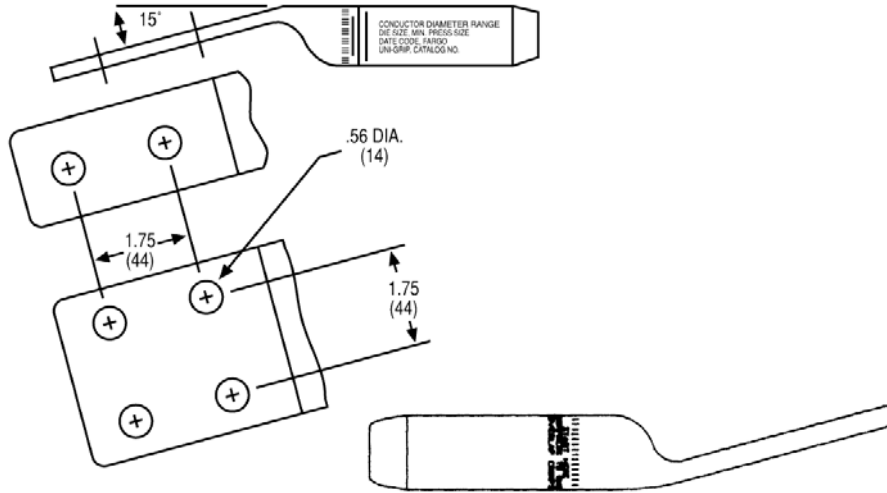

**Application:** Jumper terminals are to be used with Deadend bodies. Jumper terminals are prefilled with inhibitor. Tongue holes have NEMA spacing.

**Common Name:** Paddles

**Approved Manufacturers:** Anderson, Alcoa

PUD IDENTIFICATION		MANUFACTURER CATALOG NUMBER	
Stock Description	Stock No.	Alcoa	Anderson
Deadend, Compression, Jumper Terminal, 15°, 336 AAC 19 Strand, "Tulip"	030285	TF07	JTF07
Deadend, Compression, Jumper Terminal, 15°, 336 ACSR 26/7, "Linnet"	030286	TF08	JTF08
Deadend, Compression, Jumper Terminal, 15°, 397 ACSR 26/7, "Ibis"	030287	TF09	JTF09
Deadend, Compression, Jumper Terminal, 15°, 477 ACSR 26/7, "Hawk" or 636 AAC 37 Strand, "Orchid"	030288	TF10	JTF10
Deadend, Compression, Jumper Terminal, 15°, 636 ACSR 26/7, "Grosbeak"	030289	TF11	JTF11
Deadend, Compression, Jumper Terminal, 15°, 795 ACSR 26/7, "Drake" or 954 AAC 37 Strand, "Magnolia"	030290	TF12	JTF12
Deadend, Compression, Jumper Terminal, 15°, 1272 ACSR 45/7, "Bittern"	030291	TF15	JTF15
Deadend, Compression, Jumper Terminal, 15°, 1780 ACSR 84/19, "Chukar"	030292	TF17	JTF17



**TERMINAL PADS, BOLT-ON, BRONZE**

Originator: DSmith

Date: 6/21/2007

Approval: J Mitchell

Date: 1/11/2013

Page 1 of 1

Revision: Revised verbage.

Stds Committee Approval: Approved



**Application:** Used to connect conductor to a transformer stud terminal or a NEMA 4 hole paddle.

**Specifications:**

Material: Bronze

**Packaging and Marking:** Items shall be suitably packaged to prevent damage. The container shall be convenient for handling and storage. Manufacturer's name or symbol and catalog number shall be on each part or (and) its packaging.

**Approved Manufacturers:**

PUD IDENTIFICATION		MANUFACTURER CATALOG NUMBER
Stock Description	Stock No.	Anderson
TERMINAL, BOLT ON, BRONZE, STRAIGHT T	032940	SF-1-B-2-3



**TERMINAL PADS, WEJTAP, 2-HOLE PADDLE**

Originator: DSmith

Date: 6/21/2007

Approval: DSmith

Date: 10/8/2007

Page 1 of 1

Revision: **NEW**

Stds Committee Approval:  
**Approved**



**Application:** Used to connector conductor to a NEMA four paddle such as a overhead switch. Brundy Ampact tool is used to install each unit.

**Packaging and Marking:** Items shall be suitably packaged to prevent damage. The container shall be convenient for handling and storage. Manufacturer's name or symbol and catalog number shall be on each part or (and) its packaging.

**Shipping:** Special Shipping Instructions

**Approved Manufacturers:**

PUD IDENTIFICATION		MANUFACTURER CATALOG NUMBER
Stock No.	Stock Description	Burndy
033228	TERMINAL, WEJTAP, 2-HOLE PADDLE, #6STR-266 ACSR, #6STR 300AL	WCAB30R-2N
033232	TERMINAL, WEJTAP, 2-HOLE PADDLE, 266-556 ACSR	WCAY39R-2N
033236	TERMINAL, WEJTAP, 2-HOLE PADDLE, 605-1033 ACSR	WCAY49R-2N



**TAPS, COMPRESSION, WEJTAP AND POWER BOOSTER**

Originator: DSmith

Date: 2/13/2015

Approval: J. Mitchell

Date: 2/17/2015

Page 1 of 2

Revision:  
Removed STK# 032635

Stds Committee Approval:  
**9/22/06**



**Application:** WEJTAP connectors use an aluminum alloy wedge that is power-driven between the run and the tap cables locking them into a "C" shaped tempered aluminum alloy spring-body. The spring-body maintains pressure throughout the life of the connection to ensure reliability during severe electrical and climatic conditions.

Specification: The District has standardized on Burndy as a sole source for this product due to tooling issues.

**Packaging and Marking:** Items shall be suitably packaged to prevent damage. The container shall be convenient for handling and storage. Manufacturer's name or symbol and catalog number shall be on each part or (and) its packaging.

**Approved Manufacturers: Burndy Only**

Stock #	DESCRIPTION	Burndy
032604	WEJTAP, YELLOW RUN (ACSR, AAC) 795, TAP (ACSR, AAC, CU) 266.8, 250	WCY78 PB
032622	WEJTAP, YELLOW RUN 1033.5, 954 ACSR, 1033 AAC, TAP 795KCM ACSR, 795/954 AAC, 1000 CU	WCY87 PB
032639	WEJTAP, 250-450KCM STR CU TO 5/8" GROUND ROD	2-276337-3
032561	WEJTAP, BLUE, RUN (ACSR, AAC) #2, 1/0, #2/0, TAP (ACSR, AAC, CU) #2, 1/0	WCB10 PB
032574	WEJTAP, BLUE, RUN (ACSR, AAC) #2/0, 3/0, 4/0, TAP (ACSR, AAC, CU) #2, 1/0, #2/0	WCB11 PB
032571	WEJTAP, BLUE, RUN #4/0 ACSR/AAC, TAP #4ACSR/ AAC/CU	WCB16 PB
032577	WEJTAP, BLUE, RUN 3/0/4/0 ACSR/AAC, TAP #2/0/3/0 ACSR/ AAC/CU	WCB18 PB
032580	WEJTAP, BLUE, RUN #4/0 ACSR/AAC, TAP #4/0 ACSR/ AAC/CU	WCB20 PB
032640	WEJTAP, BLUE, RUN 336.4KCM ACSR/AAC, TAP 266.8/336.4KCM ACSR/AAC/CU	WCB47 PB
032568	WEJTAP, RED, RUN #2 ACSR/AAC, TAP #2AAC/CU	WCR30 PB
032565	WEJTAP, RED, RUN #2ACSR/AAC, TAP #4 ACSR/AAC/CU	WCR31 PB



**TAPS, COMPRESSION, WEJTAP AND POWER BOOSTER**

Originator: DSmith

Date: 2/13/2015

Approval: J. Mitchell

Date: 2/13/2015

Revision:  
Removed STK# 032635

Stds Committee Approval:  
**9/22/06**

032562	WEJTAP, RED, RUN, #6, #4 ACSR/AAC, TAP #6 ACSR/AAC/CU	WCR33 PB
032619	WEJTAP, YELLOW, RUN 954/1033.5KCM ACSR/AAC, TAP #2 ACSR/AAC/CU	WCY100 PB
032625	WEJTAP, YELLOW, RUN 397.5KCM AAC, TAP #2AAC/CU	WCY50 PB
032583	WEJTAP, YELLOW, RUN 397.5KCM AAC, TAP 1/0AAC/CU	WCY51 PB
032586	WEJTAP, YELLOW, RUN 397.5KCM AAC, TAP #4/0AAC/CU	WCY54 PB
032584	WEJTAP, YELLOW, RUN 397.5KCM AAC, TAP 336.4/397.5KCM AAC, 350 CU	WCY56 PB
032598	WEJTAP, YELLOW, RUN 556.5KCM ACSR/AAC, TAP 556.5KCM ACSR/AAC	WCY60 PB
032592	WEJTAP, YELLOW, RUN 397.5/556.5KCM ACSR/AAC, TAP 266.8/336.4/397.5KCM ACSR/AAC/CU	WCY62 PB
032587	WEJTAP, YELLOW, RUN 397.5KCM/477KCM/556.5KCM ACSR/AAC, TAP #4/0/266.8KCM ACSR/AAC/CU	WCY63 PB
032616	WEJTAP, YELLOW, DIAMTERS: RUN: 1.133-0.907, TAP 1.142-0.907	WCY73 PB
032607	WEJTAP, YELLOW, RUN 795KCM ACSR, TAP 556.5KCM ACSR	WCY74 PB
032613	WEJTAP, YELLOW, RUN 795KCM ACSR/AAC, TAP 477KCM ACSR, 556.5KCM AAC, 500CU	WCY75 PB
032610	WEJTAP, YELLOW, RUN 795KCM ACSR/AAC, TAP 336.4/397.5KCM ACSR/AAC/CU	WCY77 PB
032601	WEJTAP, YELLOW, RUN 795KCM ACSR/CU, TAP 3/0/4/0 ACSR, #4/0 AAC/CU	WCY79 PB
032589	WEJTAP, YELLOW, RUN 795KCM ACSR/AAC, TAP 1/0/2/0 ACSR/AAC/CU	WCY81 PB
028620	SHELL,WEJTAP POWER BOOSTER, RED	WPBR-BOX25
028615	SHELL,WEJTAP POWER BOOSTER, BLUE	WPBB-BOX25
028630	SHELL,WEJTAP POWER BOOSTER, WHITE	WPBW-BOX25
028625	SHELL,WEJTAP POWER BOOSTER, YELLOW	WPBY-BOX25





**Sleeves, Automatic  
Tension, Copper**

Originator: DSmith

Date: 7/7/2006

Approval: J.Mitchell

Date: 8/13/2014

Page 1 of 1

Revision: CORRECTED ITEM #

Stds Committee Approval:  
**Approved**

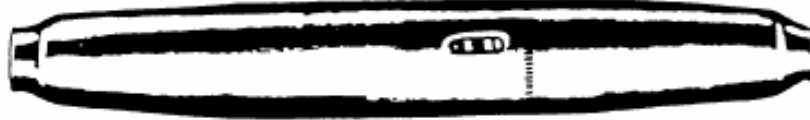

**Application**

Automatic splicing sleeve shall be full tension, straight-line, for splicing copper conductors.

**Salvage Instructions**

Automatic sleeves for copper shall not be reused except to readjust during initial installation.

**Specifications:**

**Construction:** Connectors shall be flare mouth design.

**Strength:** Connector shall be capable of holding conductor to 95% of the conductor breaking strength.

**Material:** Connector shall be constructed of copper tubing with bronze jaws that are inhibitor loaded.

**Packaging & Marking:** Items shall be suitably packaged to prevent damage. The container shall be convenient for handling and storage. Manufacturer's catalog number shall be on each part and its packaging.

**Approved Manufacturers**

PUD IDENTIFICATION		MANUFACTURERS CATALOG #	
Stock Description	Stock No.	Fargo	MacLean
SLEEVE, AUTO, FULL TENSION, #6 SOLID AND #8 STR CU	029530	GL-111	61
SLEEVE, AUTO, FULL TENSION, #4 SOL CU AND 8A CUWELD	029620	GL-112	41
SLEEVE, AUTO, FULL TENSION, #6A CU WELD, #3 SOL CU, #4 STR, CU	030790	GL-113	47
SLEEVE, AUTO, FULL TENSION, #2 SOL CU	029680	GL-114	21
SLEEVE, AUTO, FULL TENSION, 1/0 SOL, CU #1 STR CU, 3A CU WELD	029740	GL-116	101
SLEEVE, AUTO, FULL TENSION, #2/0 SOL CU, 1/0 STR CU	029770	GL-117	107
SLEEVE, AUTO, FULL TENSION, 3/0 SOL CU, #2/0 STR CU	029850	GL-118	207
SLEEVE, AUTO, FULL TENSION, #4/0 SOL CU, 3/0 STR CU	029790	GL-119	307
SLEEVE, AUTO, FULL TENSION, 4/0 STR CU	029880	GL-120	407
SLEEVE, AUTO, FULL TENSION, 250 STR CU	029910	GL-121	250
SLEEVE, AUTO, FULL TENSION, #1 SOL CU, #2 STR CU, #4A CUWELD	030880		27
SLEEVE, AUTO, FULL TENSION, REDUCER, #4CU TO #2CU	030911	GL-150	





**SLEEVE, AUTOMATIC**  
**For ACSR/AAC/AAAC Conductor**

Originator: DSmith

Date: 11/17/2010

Approval: DSmith

Date: 11/17/2010

Page 1 of 1

Revision: **NEW**

Stds Committee Approval:  
**Approved**



**Application:** Used to splice two overhead conductors together. Conductor may be same or different sizes. Initial tension representing 15% of the Conductor Rating is required to assure a permanent low resistance electrical connection. Used on ACSR, AAC and AAAC Conductor.

**Common Name:** Automatic Sleeves

**Specifications:** Each unit shall be rated to hold a minimum of 95% of the rated breaking strength of the conductor. Each unit shall be made of high strength aluminum alloy and contain inhibitor compound.

**Packaging and Marking:** Items shall be suitably packaged to prevent damage. The container shall be convenient for handling and storage. Manufacturer's name or symbol and catalog number shall be on each part or (and) its packaging.

**Approved Manufacturers:**

PUD IDENTIFICATION		Manufacturer Catalog Number				
Stock Description	Stock No.	Color Code	T&B	Hubbell	MacLean	Fargo
Sleeve, Auto, Tension, #4 ACSR/AAC/AAAC	030100	Orange	ATS4	GL402A	7651	
Sleeve, Auto, Tension, #4-#2 ACSR/AAC/AAAC	030913	Red/Orange	ATS42	GL4042A	7652AP	
Sleeve, Auto, Tension, #1/0 - #2/0 ACSR/AAC/AAAC	030220	Gray/Yellow	ATS1020	GL4076A	7654AP	
Sleeve, Auto, Tension, #3/0 - #4/0 ACSR/AAC/AAAC	030310	Pink/Black	ATS3040	GL4098	7656AP	GL-409
Sleeve, Auto, Tension, 266 – 336kcm ACSR/AAC/AAAC	029300	Green/Brown	ATS266336	GL411	7658AP	
Sleeve, Auto, Tension, 636kcm AAC	029420	Natural	-----	GL1333A	-----	



**STRANDVISE**

Originator: Jeff Flader

Date: 1/25/2012

Approval: Jeff Mitchell

Date: 1/25/2012

Revision: **NEW**

Stds Committee Approval:



**Application:** For deadend applications with overhead or down guy wire.

**Common Name:** Strandvise

**Specification:** Shall be designed to hold a minimum of 90% of rated breaking strength of the strand used.

**Ordering Description:**

- Strandvise, 6m Guy, Automatic W/Solid Bail, 13.87" W/Bail, Wire Range .215-.270, 1/4"
- Strandvise, 12.5m Guy, Automatic W/Solid Bail, 18" W/Bail, Wire Range .325-.392, 3/8"
- Strandvise, 25m Guy, Automatic W/Solid Bail, 16.3" or 20.5" W/Bail, Wire Range .455"-.520", 1/2"

**Packaging and Marking:** Items shall be suitably packaged to prevent damage. The container shall be convenient for handling and storage. Manufacturer's name or symbol and catalog number shall be on each part or (and) its packaging.

**Approved Manufacturers:**

PUD IDENTIFICATION		MANUFACTURER CATALOG NUMBER	
Stock Description	Stock No.	MACLEAN	HUBBELL
STRANDVISE, 6M GUY, AUTOMATIC W/SOLID BAIL, 13.87"	032210	5200	GDE5200
STRANDVISE, 12.5M GUY, AUTOMATIC W/SOLID BAIL, 18"	032230	5202	GDE5202
STRANDVISE, 25M GUY, AUTOMATIC W/SOLID BAIL, 16.31"	034444	5204	
STRANDVISE, 25M GUY, AUTOMATIC W/SOLID BAIL, 20.5"	032250	5204-L	



**STRANDLINK**

Originator: DSmith

Date: 7/7/06

Approval: J Mitchell

Date:  
1/25/2012  
1/25/2012  
2

Page 1 of 1

Revision: **Updated Description**

Stds Committee Approval:  
**Approved**



**Application:** An automatic full-tension splice for steel guy wire may be used to repair guy wire that is broken or moved. Do not salvage.

**Common Name:** Pickle

**Specification:** Automatic full tension splice for (size) steel guy wire. Splice shall be designed to hold a minimum of 90 percent of the rated breaking strength of the guy wire.

Breaking Strength of Steel Guy Wire	
1/4 inch	5,000 lbs
3/8 inch	16,000 lbs
1/2 inch	25,000 lbs

**Material:** Body: 6061-T6 aluminum alloy; Jaws: 1010 steel, case hardened; Spring: Hard drawn tinned steel.

**Packaging and Marking:** Each guy splice shall be filled with corrosion inhibiting compound and individually packaged to prevent damage. The container shall be convenient for handling and storage. Manufacturer's name or symbol, catalog number and guy wire size shall be permanently marked on each item.

**Approved Manufacturers:**

PUD IDENTIFICATION		Manufacturer Catalog Number	
Stock Description	Stock No	MacLean	Hubbell
Strandlink, 6m guy, 1/4"	032050	5040	GLS5040
Strandlink, 12.5m guy, 3/8"	032070	5042	GLS5042
Strandlink, 25m guy, 1/2"	032090	5044	



**CONNECTOR, BOLTED STATION BUS, STUD  
NEMA 4 HOLE PAD**

Originator: DSmith

Date: 7/7/06

Approval: DSmith

Date: 6/27/2007

Page 1 of 1

Revision: **NEW**

Stds Committee Approval:  
**Approved**

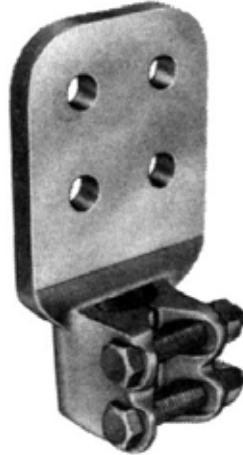

**Application:** Used to connect equipment stud terminals/Station Bus to NEMA four hole paddle.

**Specification:** Material: Bronze alloy

**Packaging and Marking:** Items shall be suitably packaged to prevent damage. The container shall be convenient for handling and storage. Manufacturer's name or symbol and catalog number shall be on each part or (and) its packaging.

**Approved Manufacturers:**

PUD IDENTIFICATION		MANUFACTURER CATALOG NUMBER		
Stock Description	Stock No.	Anderson	Gibbons	Joslyn
Connector, Stud To NEMA 4 Hole Pad	046270	HDSF10-1-3-3/8-14	GB1386	80-110/87D



Connections, Ground - Exothermic

Originator: DSmith

Date: 5/10/2005

Approval: DSmith

Date: 7/9/2007

Page 1 of 1

Revision: Added Figure Identifier

Stds Committee Approval:  
**5/14/05**

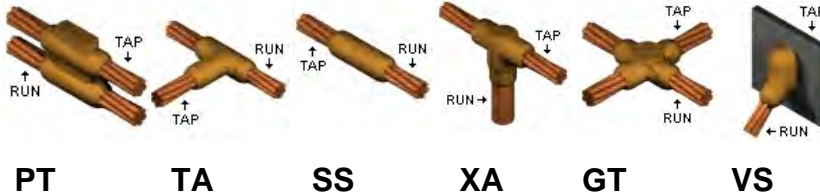

Weld Material

**Application:**

Consists of a mold filled with weld material and then ignited to produce a permanent, low resistance connection in substations. Connections shall suitable for exposure to the elements or direct burial without degradation over the lifetime of the grounding system.

**General and Safety Instructions:**

1. Welding material is an exothermic mixture and reacts to produce hot molten material with temperatures in excess of 1400°C (2500°F) and a localized release of smoke. These materials are not explosive. Ignition temperatures are in excess of 900°C (1650°F) for welding material.
2. Make connections in conformance with Manufactures instructions and all governing codes.

**Packaging and Marking:** Items shall be suitably packaged to prevent damage. The container shall be convenient for handling and storage. Manufacturer's name or symbol and catalog number shall be on each part or (and) its packaging.

**Current Approved Manufacturers:**

Stock No.	Maximo Description	Fig	MFG CATALOG NUMBER		
			CADWELD	Weld Metal Type	Unit
11329	Connector Mold, Exothermic, Tee, 350 Run - 4/0 Tap	TA	TAC3D2Q	150	Each
11330	Connector Mold, Exothermic, Splice, 350 Run – 350 Tap	SS	SSC3D,	150	Each
11449	Connector Mold, Exothermic ,4/0 Cable-Flat Steel Surface	VS	VSC3D	200	Each
11450	Connector Mold, Exothermic, 4/0 Cable-2" Pipe Surface	VS	VSC2QV2	115	Each
080006	Connector Mold, Exothermic, 4/0 Cable To 3/4" Ground Rod	GT	GTC182Q	115	Each
080004	Connector Mold, Exothermic, Cross, 4/0 Run - 4/0 Tap	XA	XAC2Q2Q	200	Each
080000	Connector Mold, Exothermic, Parallel, 4/0 Run - 4/0 Tap	PT	PTC2Q2Q	200	Each
080008	Connector Mold, Exothermic, Splice, 4/0 Run - 4/0 Tap	SS	SSC2Q	90	Each
080002	Connector Mold, Exothermic, Tee, 4/0 Run - 4/0 Tap	TA	TAC2Q2Q	150	Each
080009	Connector, Mold, Exothermic, 4/0 Cable To 2-3/8" Steel Pipe	VS	VSC2QV2.5	115	Each
165246	Connector, Exothermic, Weld Metal #90		90	n/a	Box of 20
100401	Connector, Exothermic, Weld Metal #115		115	n/a	Box of 20
147235	Connector, Exothermic, Weld Metal #150		150	n/a	Box of 20
147236	Connector, Exothermic, Weld Metal #200		200	n/a	Box of 20
100402	Connector, Exothermic, Weld Metal #250		250	n/a	Box of 20



# CONNECTORS Underground

Originator: DSmith

Date: 7/11/2007

Approval: DSmith

Date: 7/11/2007

Page 1 of 1

Revision: **NEW**

Stds Committee Approval:  
**Approved**



# CONNECTORS Underground

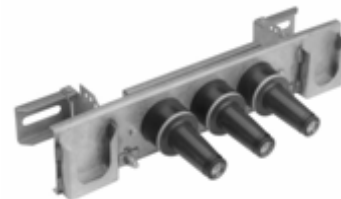



**Terminations, UG 15kV Cable,  
 COLD SHRINK**

Originator: DSmith

Date: 7/2/2007

Approval: DSmith

Date: 10/8/2008

Page 1 of 1

Revision: Changed 9" to 6" stinger

Stds Committee Approval:  
**Approved**

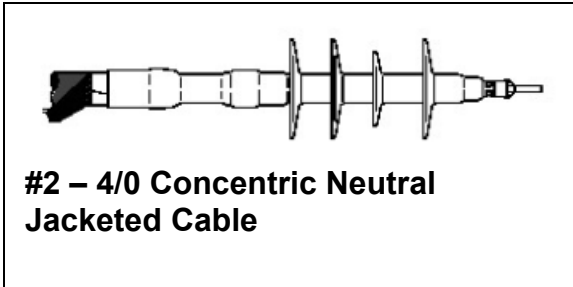

**#2 - 4/0 Concentric Neutral Jacketed Cable**

**Application:** This primary cable terminator shall provide a weather tight seal to connect 15 kV jacketed concentric neutral cables or tape shield neutral cables to overhead distribution facilities. It shall be suitable for Indoor & outdoor installations.

**Specification:** This skirted termination kit shall be designed for jacketed UG cable, and contain all necessary components for cable termination including silicone molded rubber termination, connectors (if specified), rubber tape, clips, springs, ground braids (if required), silicone grease and 1 instruction sheet.

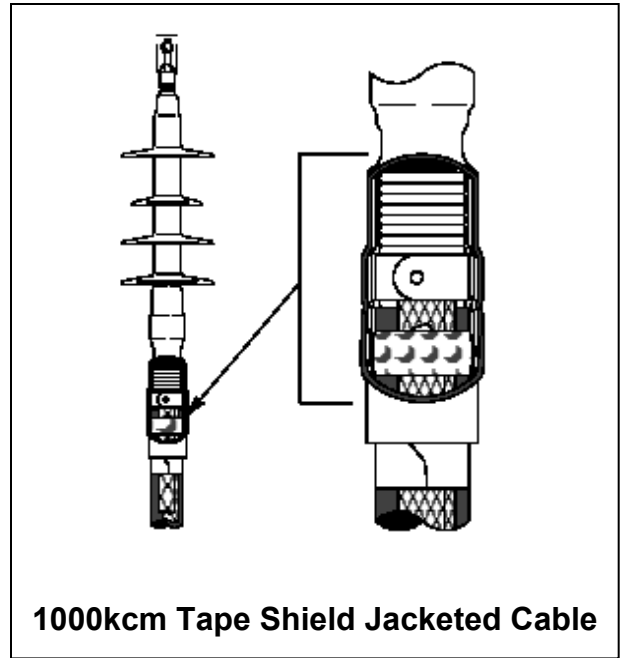

**1000kcm Tape Shield Jacketed Cable**

The insulators shall be pre-stretched around a spiral -wound, plastic core. When the terminator is slipped over a properly prepared cable and the core is removed, the terminator immediately shrinks to the cable's dimensions. The result is a void-free, flexible seal without special tools or torches.

**Packaging and Marking:** Items shall be suitably packaged to prevent damage. The container shall be convenient for handling and storage. Manufacturer's name or symbol and catalog number shall be on each part or (and) its packaging.

**Approved Manufacturers:**

Stock No.	PUD IDENTIFICATION Stock Description	MANUFACTURER CATALOG NUMBER	
		3M	MFG 2
049050	TERM, CABLE, 15KV #2 AL JKT CU CN, COLD SHRINK SILICONE RUBBER KIT, 110kV BIL W/ 6" STINGER	7642-S-2-2	
049280	TERM KIT, CABLE, 15KV #4/0 AL JKT CU CN, COLD SHRINK SILICONE RUBBER KIT, 110kV BIL W/ 6" STINGER	7642-S-2-4/0	
049290	TERM, 15KV CABLE, 750-1000 KCM AL, CU TAPE SHIELD, COLD SHRINK, 150KV BIL, NO CONNECTOR, 3 PER KIT	7655-S-HSG-4	





**SLEEVES/SPLICES, UG 15Kv CABLE**

Originator: DSmith      Date: 7/7/06

Approval: DSmith      Date: 8/7/2008

Revision: Moved 600V splices to 1019.11

Stds Committee Approval:  
**Approved**



**UG 15kV Cable Splice, Cold Shrink**



**UG 15kV Splice, one piece**

**Application:** Used to splice underground secondary or primary cable.

**Packaging and Marking:** Items shall be suitably packaged to prevent damage. The container shall be convenient for handling and storage. Manufacturer's name or symbol and catalog number shall be on each part or (and) its packaging.

**Approved Manufacturers:**

PUD IDENTIFICATION		MANUFACTURER CATALOG NUMBER	
Stock Description	Stock No.	3M	Other
SPLICE, ONE-PC. W/ COMP INSERT, 9.5"L, #2AL 15kV UG	048500	5411-CI-21	COOPER SP15A002
SPLICE, ONE-PC. W/ COMP INSERT, 11.1"L, 1/0 15kV UG	048600	5411-CI-1/0	
SPLICE, ONE-PC. W/ COMP INSERT, 11.1"L, #1 15kV UG	048610	5411-CI-21	
SPLICE, ONE-PC. W/ COMP INSERT, 11.1"L, 4/0 15kV UG	048620	5412-CI-4/0	
SPLICE, 1000KCM, 19"L, 15Kv UG, 600amp	048680	5516-1000-AL	
SPLICE, STRAIGHT LINE, COND. SHLD., .625"-.735"	048700		ELASTIMOLD: 25SFAB1AX
SPLICE, RED IN LINE, TYPE A KIT, 15kV, 600AMP, 11"L	048850		ELASTIMOLD: 25SFB1AX
SPLICE, IN LINE KIT, 15KV, 3PH SOLID, ARMORED CABLE, 63"L, #2-4/0	048900		RAYCHEM: SMO-AE1024 HVA- 3-1521
SPLICE, IN LINE CABLE REPAIR, 15KV, 16"L, #1STR W/ CN, #1-1/0SOL W/ CN	048505	5411R-CIR-21	





**CABLE SEALING KITS & CAPS**

Originator: DSmith

Date: 7/25/2006

Approval: DSmith

Date: 6/27/2007

Page 1 of 1

Revision: **NEW**

Stds Committee Approval:  
**Approved**

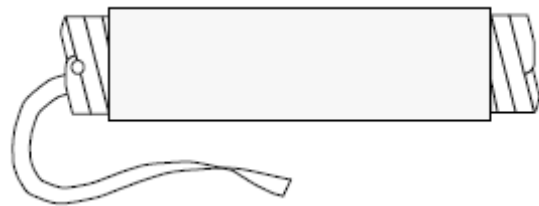

**Cold Shrink Cable Sealing Kit**



**Cap, Cable End Seal**

**Application:** Used to seal jacketed primary cable when installing elbows or to seal the end of the primary cable still remaining on the reel.

**Packaging and Marking:** Items shall be suitably packaged to prevent damage. The container shall be convenient for handling and storage. Manufacturer's name or symbol and catalog number shall be on each part or (and) its packaging.

**Shipping:** Special Shipping Instructions

**Approved Manufacturers:**

PUD IDENTIFICATION		MANUFACTURER CATALOG NUMBER		
Stock Description	Stock No.	3M	T&B	Homac
CONNECTOR, CABLE SEALING KIT, COLD SHRINK, 15KV, 5"L, #2-4/0 JACKETED	048200	8452	200ECS	-
CONNECTOR, CABLE SEALING KIT, COLD SHRINK, 15KV, 6.5"L, 2/0-1000KCM JACKETED	048300	8453	600ECS	-
CAP, CABLE END SEAL, 1000MCM, 3"L, 1.86"-2.23", RUBBER	047050	-	-	CAP-150



**Elbow, 15kV 200 Amp Loadbreak  
With Test Point and  
Integrated Jacket Seal**

Originator: D. Smith

Date: 9/14/2010

Approval: J. Mitchell

Date: 11/30/11

Page 1 of 1

Revision: Removed Elastimold from approved standards due to operational problems.  
Updated Cooper Catalog Number. Removed Hubbell. Changed title.

Stds Committee Approval:  
**Approved**



**Application:** The 200 amp loadbreak separable elbow-bushing connector is suitable for connecting URD underground cable to URD transformers and switchgear. It provides a grounded, deadfront, submersible cable connection. Loadbreak and load make operations require the aid of a live-line tool (shotgun stick with elbow puller).

**Specification:** The loadbreak elbow will be supplied with voltage test point and pulling eye. The elbow male contact rod and the threaded cable compression connector shall be designed to assure a secure, low resistance connection. Bi-metallic construction is required for the connector, with aluminum crimp tube and copper threaded to accept copper contact rod. The connector shall be prefilled with inhibitor. The loadbreak elbow shall meet all the requirements of ANSI/IEEE 386 - latest revision. A method of sealing the elbow to the URD cable shall be provided by a built in jacket seal.

**Voltage Rating:** The elbow and bushing shall be capable of closing on or opening full phase-to-phase voltage.

**Current Rating:** The elbow and bushing shall be capable of conducting 200 amps continuously and 10,000 amps for 10 cycles momentary or during fault closure at maximum phase-to-phase voltage.

**Packaging and Marking:** Items shall be suitably packaged to prevent damage in separate polyethylene bags. The container shall be convenient for handling and storage. Manufacturer's name or symbol and catalog number shall be on each part or (and) its packaging.

**Approved Manufacturers:**

PUD IDENTIFICATION		MANUFACTURER CATALOG NUMBER	
Stock Description	Stock No.	Cooper	Hubbell
Elbow, #2 str 15kv, 200amp, Loadbreak W/Test Point and Integrated Jacket Seal.	044950	LEJ215AB04T	215LEJ43T
Elbow, #1/0 str - #2/0 Solid, 15kv, 200amp, Loadbreak W/Test Point and Integrated Jacket Seal	045110	LEJ215AB06T	215LEJ45T
Elbow, #4/0 str, 15kv, 200amp, Loadbreak W/Test Point And Integrated Jacket Seal	045250	LEJ215DD09T	215LEJ58T



**ELBOW, 600AMP, 15Kv,  
NON-LOAD BREAK  
UG CABLE TERMINATION SYSTEM**

Originator: DSmith

Date: 4/10/2007

Approval: DSmith

Date: 4/10/2009

Page 1 of 3

Revision: **NEW**

Stds Committee Approval:  
**Approved**

**Application:** The 600Amp 15kV rated LRTP Deadbreak Termination System is designed to connect medium voltage UD cable to switchgear, transformers, sectionalizing cabinets and UD vault applications. It is fully compliant with IEEE-386 Standard and mates with bushing components that also comply with the IEEE-386 Standard.

The LRTP system uses a threaded compression lug allowing the LRTP to be threaded into the T-body forming an integral termination system. The LRTP system is ideal for applications where the termination will be moved to achieve a visible break and ground. The integral termination system, T-body and LRTP as one unit, makes it easier to install and remove from the mating bushing interface. This interface allows for live test, phasing and visible ground. In addition, it can be used to add a tap, or install an Arrester Elbow to protect the system from voltage surges.

**Common Name:** Hammer Heads

# LRTP Elbow Termination System

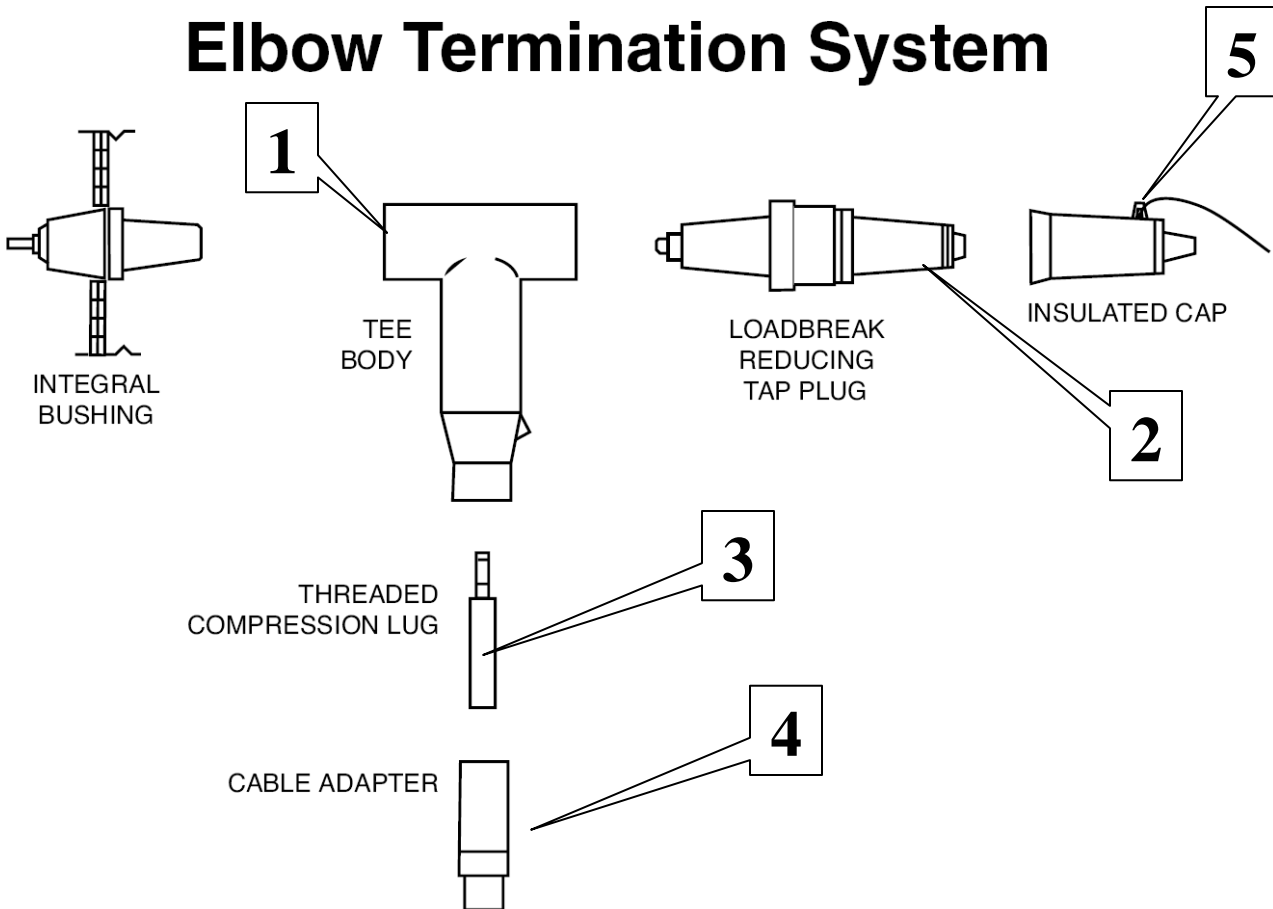



**ELBOW, 600AMP, 15Kv,  
NON-LOAD BREAK  
UG CABLE TERMINATION SYSTEM**

Originator: DSmith

Date: 4/10/2007

Approval: DSmith

Date: 4/10/2009

Page 2 of 3

Revision: **NEW**

Stds Committee Approval:  
**Approved**

Item #	Application	
1	<b>T-Body</b> - The Deadbreak Elbow is designed to terminate power cables with copper or aluminum conductors ranging in sizes from #2 AWG to 1250MCM. It may be installed on any 600 amp rated (aluminum) or 900 amp rated (copper) deadbreak apparatus bushing that meets IEEE Standard 386 latest revision for Separable Insulated Connectors.	
2	<b>LRTP</b> - The 600/900 amp LRTP is designed to tap a 200 amp loadbreak interface device to an existing 600/900 amp deadbreak using a bolted connection. A common application is for grounding and isolating 600/900 amp systems. The LRTP is fault-close rated to 10,000 amps and complies with IEEE 386.	
3	<b>Connector Compression</b> , Copper Top Threaded This is a bimetal compression connector that is thread with a 15/16 hole.	
4	<b>Cable Adapters</b> accommodate power cable insulation diameters from 0.530 to 1.935 inches	
5	<b>Insulating Protective Cap</b> - The insulating cap isolates unused 600 amp interfaces.	
6	<b>Connecting Plug</b> is required exclusively for applications involving the joining or connecting of two or more molded 600 elbows. Wrench holes are provided to tighten the Connecting Plug into a 600 or 900 amp Deadbreak Elbow by using a standard spanner wrench.	
7	<b>Basic Insulating Plug with Cap</b> - The Basic Insulating Plug is required to secure the molded rubber 600 amp elbow in place.	
8	The <b>Torque Tool</b> is required to check the torque of a 15 kV Class T-OP II deadbreak connector or bushing adapter when it is installed on a 600 A bushing interface. It is precision calibrated and shotgun stick operable.	
9	<b>T-WRENCH</b> , The T-Wrench is used to install the Loadbreak Reducing Tap Plug into the Bushing Extender.	
10	<b>SHIELD ADAPTERS/SEALING AND GROUNDING KIT</b> Used for cold shrink sealing and grounding tape shielded cables.	



**ELBOW, 600AMP, 15Kv,  
NON-LOAD BREAK  
UG CABLE TERMINATION SYSTEM**

Originator: DSmith

Date: 4/10/2007

Approval: J Mitchell

Date: 11/30/2011

Page 3 of 3

Revision: **Updated Cooper Catalog #'s**

Stds Committee Approval:

**Approved**

**Approved Manufacturers:**

PUD IDENTIFICATION		MANUFACTURER CATALOG NUMBER			
Item	Stock Description	Stock No.	Hubbel	Elastimold	Cooper
1	Elbow, Tee Body W/Test Point, 15kv/25kv, 600amp, (Hammerhead)	045350	625TBT		DT625T
2	Plug, Load Reducing Tap, Load Break W/Extended Stud, 15kv, 200amp (LRTP For Hammerhead)	047020	615LRTP		LRTP615
3	Connector, Compression, Copper Top #1000 Al With 15/16" Threaded Hole For Hammerhead	044530	625LUGB41T	04601-410	CC6C27T
3	Connector, Compression, Copper Top 750kcm Al & Copper With 15/16" Threaded Hole For Hammerhead	044520	625LUGB38T	#04601-380	CC6C25T
3	Connector, Compression, Copper Top #4/0 Al With 15/16" Threaded Hole For Hammerhead	044460	625LUGB27T		CC6C16T
4	Cable Adapter, 1000 kcm, For Hammerhead Elbow, 1.58"	040530	625CAM	655C-A-N	CA625GG
4	Cable Adapter, 750 kCM, For Hammerhead Elbow 1.37 – 1.43	040500	625CAM		CA625FF
4	Cable Adapter, 15kV, 175mil #4/0 CN (0.93"), For Hammerhead Elbow	040400	625CAH	655 CA-GB	CA625CC
5	Insulating Protective Cap	041850	625IC		DPC625UT
6	Connecting Plug	046900	625CP		DCP625A
7	Basic Insulating Plug with Cap (w/o Stud)	047000	625BIP		DIP625A
8	Wrench Torque Tool For 600 Amp 15kV Hammerhead Interfaces	041655			TQHD625
9	T-Wrench for Hammerheads	Tool Rm			TWRENCH
10	Grounding Adapter for Drain Wire Tape shield Cable - 1000kcm Al Or Cu	041900		30MAKA	
11	Grounding Adapter for Drain Wire Tape shield Cable - 750kcm Al Or Cu	041870	2637326B17M	21 MA-JB	
12	Basic Insulating Plug w/cap and stud	046950		600DP	DIP625AS
13	Cold Shrink Adapter Kit for 350-1000MCM w/copper braid and spring	048250			SA3

**Packing and Marking:** Items shall be suitably packaged to prevent damage. The container shall be convenient for handling and storage. Manufacturer's name or symbol and catalog number shall be on each part or (and) its packaging.



JUNCTION BARS, 15KV FOR  
600A AND 200A SEPARABLE CONNECTORS

Originator: DSmith

Date: 7/20/2006

Approval: DSmith

Date: 7/9/2007

Page 1 of 3

Revision: **NEW**

Stds Committee Approval:  
**Approved**

PUD IDENTIFICATION			MANUFACTURER CATALOG NUMBER		
Item #	Stock Description	Stock No.	Thomas & Betts	Cooper Power	Patton & Cooke
1	Junction Bar, 15kV, Four 200A Load Break junctions with stainless steel mounting bracket and two parking stands.	041440	164J4CS842	LJ215C4B	
2	Junction Bar, 15kV, two 600A and four 200A positions with stainless steel mounting multiposition bracket and two parking stands.	041441	J662222615 TMA	JB125C1B4W1BPS	JB-1B/4A/1B-11 with multiposition mtg bracket

**Item 1. 600A Deadbreak /200A Loadbreak**

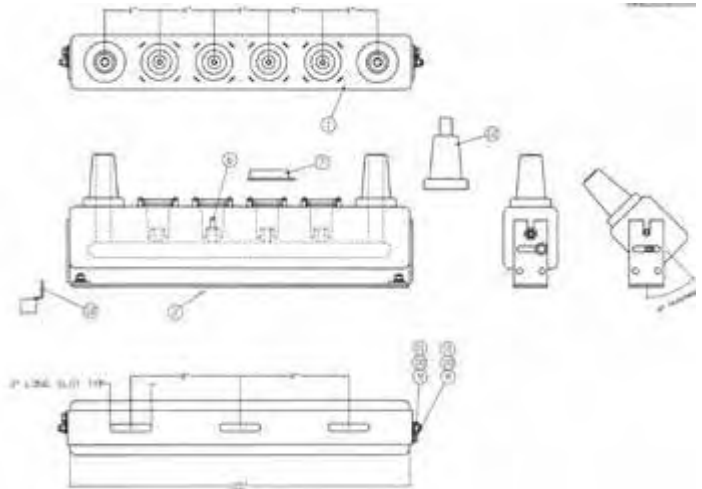

**Application:** Installed in UG sectionalizing vaults and provides transition from 600 amp connections to 200 amp.

**Specification:** Provided with protective covers and universal stainless steel mounting brackets that can provide mounting angles from 0 to 90 degrees. Two single stainless steel parking stands shall be provided per junction bar for mounting on each end. All current carrying components shall be copper. The universal 200Amp bushing wells shall have replaceable electroplated high strength chromium copper studs.

**NOTES:**

These junction bars do not come with 200Amp bushing inserts (Stock #045870), each unit requires four inserts.





JUNCTION BARS, 15KV FOR  
600A AND 200A SEPARABLE CONNECTORS

Originator: DSmith

Date: 7/20/2006

Approval: DSmith

Date: 7/9/2007

Page 2 of 3

Revision: NEW

Stds Committee Approval:  
**Approved**

**Item 2. 200A Load Break**

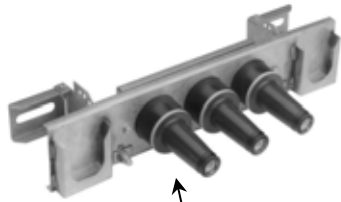

**Note: District requires four junctions:**

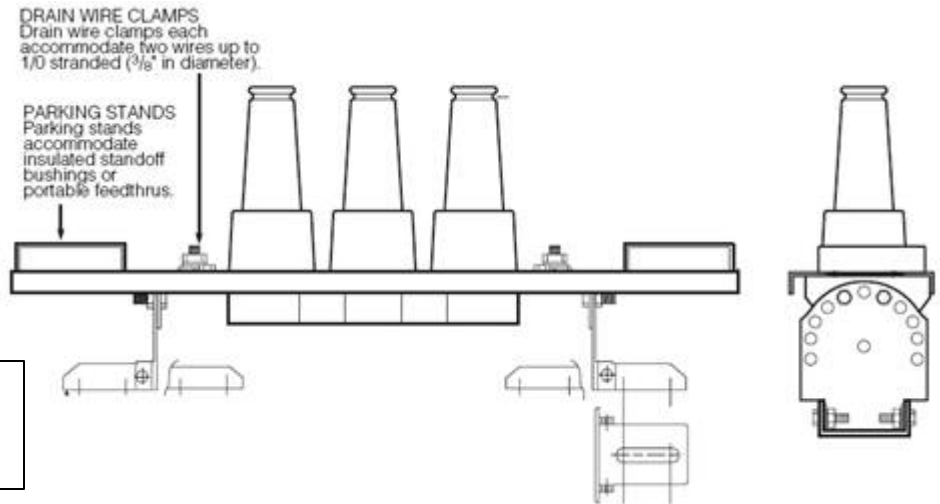

**Application:** Installed in sectionalizing vaults and cabinets to terminate 200 Amp 15kV UG cable.

**Specification:** Multiposition junction bar with 200A bushings. Each unit is provided with protective covers and universal stainless steel mounting brackets that can provide mounting angles from 0 to 90 degrees. All current carrying components shall be copper. Two single stainless steel parking stands shall be provided per junction bar and are mounting on each end. Two drain wire clamps shall be provided. Each shall accommodate two wires up to 1/0 stranded (3/8" diameter).

Each bushing shall include a bright yellow latch indicator ring, located on the circumference of the interface collar for determining if the elbow is properly installed.

**3. GENERAL:**

Class	200 Amp	600 Amp
Operating Voltage (Max continuous line-to ground, 100% insulation system)	8.3kv	8.3kv
BIL	95 BIL	125 BIL
Current @ 90°C Continuous Operating Temperature	200 Amp	600 Amp
Current – Short-Time	10kA sym. 10 cycles	25kA sym. 10 cycles

**Applicable Standards:** All separable connectors shall be designed and manufactured to ANSI/IEEE Standard 386 and tested in accordance with IEEE #48.

**Packaging and Marking:** Items shall be suitably packaged to prevent damage. The container shall be convenient for handling and storage. Manufacturer's name or symbol and catalog number shall be on each part or (and) its packaging.



**JUNCTION BARS, 15KV FOR  
600A AND 200A SEPARABLE CONNECTORS**

Originator: DSmith

Date: 7/20/2006

Approval: DSmith

Date: 7/9/2007

Page 3 of 3

Revision: **NEW**

Stds Committee Approval:  
**Approved**





CAP, LOADBREAK INSULATING  
WITH DRAIN WIRE  
15KV, 200AMP

Originator: DSmith

Date: 6/12/2007

Approval: DSmith

Date: 7/9/2007

Page 1 of 1

Revision: **NEW**

Stds Committee Approval:

**Approved**

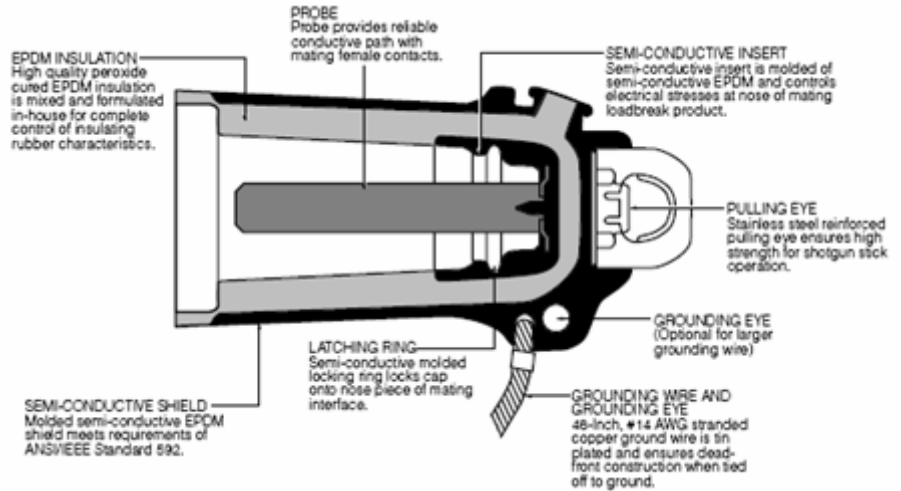

**Application:** Used to Insulated and shield Energized 15kV Bushings.

**Specification:** The Insulated Protective Cap is an accessory device designed to electrically insulate and mechanically seal loadbreak bushing interfaces. When mated to a loadbreak product and the drain wire is attached to ground, the Insulated Protective Cap provides a fully shielded, submersible insulating cover for energized bushings. The cap can be used for permanent or temporary installation on bushings, junctions or feedthru devices that meet the requirements of ANSI/IEEE Standard 386.

Each kit shall contains.

- Protective Cap with stranded copper ground wire
- Silicone Lubricant
- Installation Instruction Sheet

**Applicable Standards:** All separable connectors shall be designed and manufactured to ANSI/IEEE Standard 386 and tested in accordance with IEEE #386.

**Packaging and Marking:** Items shall be suitably packaged to prevent damage. The container shall be convenient for handling and storage. Manufacturer's name or symbol and catalog number shall be on each part or (and) its packaging.

PUD IDENTIFICATION		MANUFACTURER CATALOG NUMBER		
Stock Description	Stock No.	Thomas & Betts	Cooper Power	HUBBELL
CAP, LOADBREAK INSULATING WITH DRAIN WIRE 15KV, 200AMP	041860	167DRG	LPC 215	215ICI



**CONNECTOR, BAR, SLIP FIT  
FOR PADMOUNT TRANSFORMER**

Originator: DSmith

Date: 10/16/2007

Approval: DSmith

Date: 1/4/2008

Page 1 of 1

Revision: NEW SHEET – MOVED ITEMS FROM 1010.27

Stds Committee Approval:

**Approved**

**Application:** Used for providing multiple set screw terminations for padmounted transformers. Designed to slip on the transformer stud and then tightened with two set screws which facilitate changing out the transformer without having to remove all secondary services.



**Specification:**

- Dual-rated connectors for aluminum or copper conductors
- Clear plated for low-contact resistance.
- Fully tested to ANSI C119.4 for Class ‘A’ connectors.
- Supplied with radial-tipped set-screws.
- Connector fabricated from 6061-T6 aluminum alloy for conductivity and strength.
- Includes Oxide Inhibitor grease.

**Packaging and Marking:** Items shall be suitably packaged to prevent damage. The container shall be convenient for handling and storage. Manufacturer’s name or symbol and catalog number shall be on each part or (and) its packaging.

**Approved Manufacturers:**

PUD IDENTIFICATION		MANUFACTURER CATALOG NUMBER			
Item No.	Item Description	CMC	UTILCO	HOMAC	T&B
040140	CONNECTOR, BAR, AL, 4 POS., #12-350 AAC/CU 5/8”-11 SLIP FIT	NSSM 350-4I	PTF4350J	CSW4350	TSB4359D58
040160	CONNECTOR, BAR, AL, 6 POS., #12-350 AAC/CU 5/8”-11 SLIP FIT	NSSM 350-6I	PTF6350J	CSW6350	TSB6359D58
040165	CONNECTOR, BAR, AL, 6 POS., #2-500 AAC/CU 5/8”-11 SLIP FIT	NSSM 500-6IA	NONE	CSW6500-58	TSB6559D58
040170	CONNECTOR, BAR, AL, 6 POS., #2-500 AAC/CU 1”-14 SLIP FIT	NSSM 500-6I	PTF6500J	CSW 6500	TSB6559D51 A



**BUSSBAR, 600V INSULATED  
SUBMERSIBLE**

Originator: DSmith

Date: 7/7/06

Approval: J. Mitchell

Date: 6/27/2014

Page 1 of 1

Revision: Added 8 Pos., #2-750 kcm AAC/CU.

Stds Committee Approval:  
**Approved**



SSBC



**Application:** Used for connecting multiple secondary conductors in a hand hole or secondary vault using twin set screws.

**Specification:**

- Dual-rated connectors for aluminum or copper conductors
- Clear plated for low-contact resistance.
- Fully tested to ANSI C119.4 for Class 'A' connectors.
- Supplied with twin radial-tipped set-screws.
- Connector fabricated from 6061-T6 aluminum alloy for conductivity and strength.
- Watertight – Outlets sealed with EPDM rubber insulating sleeves
- Includes oxide inhibitor.
- 350Kcm size must come supplied with EZ Torque Limiting Screws

**Packaging and Marking:** Items shall be suitably packaged to prevent damage. The container shall be convenient for handling and storage. Manufacturer's name or symbol and catalog number shall be on each part or (and) its packaging.

**Approved Manufacturers:**

PUD IDENTIFICATION		MANUFACTURER CATALOG NUMBER	
Stock Description	Stock No.	HOMAC	CMC
Connector, Submersible, Twin Set Screw, 4 Pos., #6 - 350kcm AAC/CU	050150	UH 4 R	NA
Connector, Submersible, Twin Set Screw, 6 Pos., #6 - 350kcm AAC/CU	050160	UH 6 R	NA
Connector, Submersible, Twin Set Screw, 8 Pos., #6 - 500kcm AAC/CU	050170	UH 500-8 R	NA
Connector, Submersible, Twin Set Screw, 6 Pos., #2 - 750kcm AAC/CU	050165	UH 1000-6 R	SSBC750-6I
Screws, Homac 5/8" EZ Torque Limiting	050453	HA-508-300	
Connector, Submersible, Twin Set Screw, 8 Pos., #2 - 750 kcm AAC/CU	050455	UH 1000-8 R	SSBC750-8I



**CONNECTOR, PADMOUNT XMR SECONDARY  
SET SCREW BAR TO NEMA PADDLE**

Originator: DSmith

Date: 10/16/2007

Approval: DSmith

Date: 1/11/2008

Page 1 of 1

Revision: Changed from 1010.28 to 1019.10

Stds Committee Approval:

9/22/06



**Application:** Used to provide connect multiple secondary conductors to NEMA 4 hole paddles on large Padmount Transformers up to 750KCM.

**Specification:**

- Manufactured from high strength 6061-T6 aluminum alloy – for use with copper or aluminum conductor - Tin Plated
- Rated for 600 volts for reliability
- Range taking for reduced inventory needs
- Clear plated for low contact resistance
- Meets or exceeds ANSI 119.4 Class A specifications
- Includes CO-OX oxide inhibitor in each conductor hole.

**Packaging and Marking:** Items shall be suitably packaged to prevent damage. The container shall be convenient for handling and storage. Manufacturer’s name or symbol and catalog number shall be on each part or (and) its packaging.

**Approved Manufacturers:**

PUD IDENTIFICATION		MANUFACTURER CATALOG NUMBER		
Stock Description	Stock No.	CMC	UTILCO	HOMAC
Connector, 1/0-750kcm Al/Cu, 6 Position	015300	L6D10-750 Tin Plated	USG2-750R106 Tin Plated	ABT-6750TP



**UG SLEEVES AND SPLICES, 600V CABLE**

Originator: DSmith

Date: 12/6/2010

Approval: DSmith

Date: 12/6/2010

Page 1 of 1

Revision:

Stds Committee Approval:  
**Approved**

**Uninsulated UG Sleeve**



**Secondary  
Submersible  
"Flood Seal"**

**Application:** Used to splice either copper or aluminum underground secondary cable. Aluminum compression sleeve with solid center barrier. Designed for commercial and heavy residential services. Installed with standard tooling. Pre-filled with PENETROX™ joint compound, and capped

**Packaging and Marking:** Items shall be suitably packaged to prevent damage. The container shall be convenient for handling and storage. Manufacturer's name or symbol and catalog number shall be on each part or (and) its packaging.

PUD IDENTIFICATION		MANUFACTURER CATALOG NUMBER		
Stock No.	Stock Description	BURNDY	Other	Anderson
030160	SLEEVE, COMP, UNINSULATED UG, #2/0-#1/0	YSD26R25R		VAUS-2/0-1/0
047710	SLEEVE, COMP, UNINSULATED UG, 350-350	YCR32RG7		
047660	SLEEVE, COMP, NONTENSION, #2/0-#2/0	YSD26R26R		VAUS-2/0-2/0
047720	SLEEVE, COMP, UNINSULATED UG,	YCR361RG8		
044557	SLEEVE, COMP, UNINSULATED UG, 1000KCM	YS44A1		
045488	SPLICE COVER, SUBMERSIBLE, "FLOOD SEAL", LENGTH - 12 INCHES, #14 - 500		HOMAC FSS-500L	
048165	SLEEVE COVER, HEATSHRINK, 250-750KCM, 600V		3M - ITSCN20009	
047670	SLEEVE, COMP, UNINSULATED UG, #3/0-2/0	YSD27R26R		VAUS-3/0-2/0
047680	SLEEVE, COMP, UNINSULATED UG, #4/0-#2/0	YSD28R26		VAUS-4/0-2/0
047690	SLEEVE, COMP, UNINSULATED UG, #4/0-#4/0	YSD28R28R		VAUS-4/0-4/0
047695	SLEEVE, COMP, UNINSULATED UG, #4/0-250	YCR291RG4		
047700	SLEEVE, COMP, UNINSULATED UG, #4/0-350	YCR32RG4		
047730	SLEEVE, COMP, UNINSULATED UG, 500-500	YCR361RG10		
047740	SLEEVE, COMP, UNINSULATED UG, 336-336	YCR30RG9		
047750	SLEEVE, COMP, UNINSULATED UG, #1/0-#1/0	YSU25R25R		
047755	SLEEVE, COMP, UNINSULATED UG, #2-#2 (RED)	YSU2R2R		VAUS-1-1
047760	SLEEVE, COMP, UNINSULATED UG, 500-750	YR39A34CAY		
047770	SLEEVE, COMP, UNINSULATED UG, 1/0-2	YSU25R2R		VAUS-1/0-1/0
047780	SLEEVE, COMP, UNINSULATED UG, #2/0-4	YSD26R2R		VAUS-2/0-4
047790	SLEEVE, COMP, UNINSULATED UG, 3/0-1/0	YCR291RG4		VAUS-3/0-1/0
047800	SLEEVE, COMP, UNINSULATED UG, #4/0-1/0	YSD28R25R		VAUS-4/0-1/0
047810	SLEEVE, COMP, UNINSULATED UG, #4/0-#3/0	YSD28R27R		VAUS-4/0-3/0
047820	SLEEVE, COMP, UNINSULATED UG, 350AL-250AL	YCR32RG5		
047830	SLEEVE, COMP, UNINSULATED UG, 700/750	YS39AM1		



# LINE EQUIPMENT

Originator: DSmith

Date: 7/9/2007

Approval: DSmith

Date: 7/9/2007

Page 1 of 1

Revision: **NEW**

Stds Committee Approval:  
**Approved**



# SECTION 1200 LINE EQUIPMENT







**Regulators, Voltage**

Originator: DSmith

Date: 7/9/2007

Approval: DSmith

Date: 7/9/2007

Revision: **NEW**

Stds Committee Approval:  
**Approved**



**Application:** These devices provide for automatic +/- 10% regulation of primary voltage on the Districts distribution system.

**Specifications:** Refer to equipment specification #1211.01 for detail information. This specification covers electrical, mechanical and safety features and characteristics of outdoor, single phase, oil immersed, 60 Hz, 65°C temperature rise by resistance, self cooled and force-air cooled step-type voltage regulators.

The voltage regulators must be completely self contained and provide +/- 10% voltage regulation in thirty-two (32) steps of 5/8% each. The voltage regulator shall be of a sealed tank design that will allow operation at 65°C without increasing the oxidation rate of the oil.

The basic impulse level (BIL) shall be 95 kV. The nominal system voltage will be 12,470 GRD Y/ 7200 volts. Single-phase operation shall be at a nominal voltage of 7200 volts.

**Standards:** - The regulators furnished under this specification shall be designed, manufactured, and tested in accordance with ANSI Standard C57.15, latest revision thereof. That standard shall be a part of this specification

**Shipping:** Refer to equipment specification #1211.01

**Reference:** Refer to Material Catalog #1211.02 for controls information.

**Approved Manufacturers: Cooper, Siemens**

PUD IDENTIFICATION		MANUFACTURER CATALOG NUMBER		
Stock Description	Stock No.	MFG #1	MFG #3	MFG #3
Line Regulator, 1 Phase, 38 kVA, 50AMP	088961			
Line Regulator, 1 Phase, 57 kVA, 75AMP	088962			
Line Regulator, 1 Phase, 76 kVA, 100AMP	088963			
Line Regulator, 1 Phase, 114 kVA, 150AMP	088964			
Line Regulator, 1 Phase, 167 kVA, 219AMP	088965			
Line Regulator, 1 Phase, 250 kVA, 328AMP	088966			
Line Regulator, 1 Phase, 333 kVA, 437AMP	088967			





**Regulators, Voltage**

Originator: DSmith

Date: 7/9/2007

Approval: DSmith

Date: 7/9/2007

Revision: **NEW**

Stds Committee Approval:  
**Approved**

**Approximate Dimensions:**

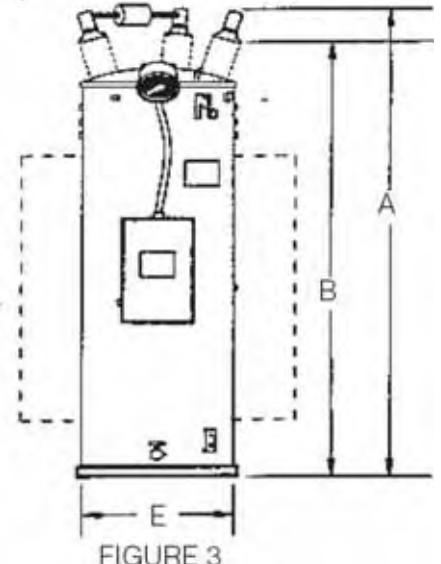
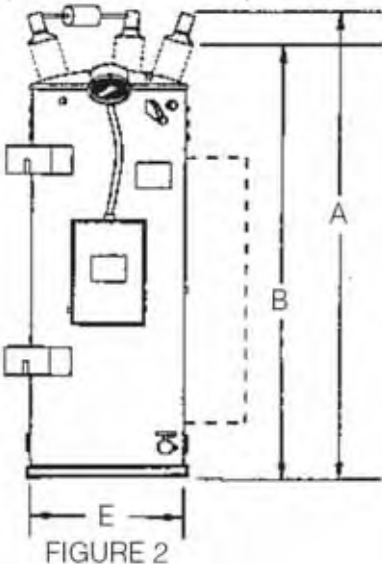
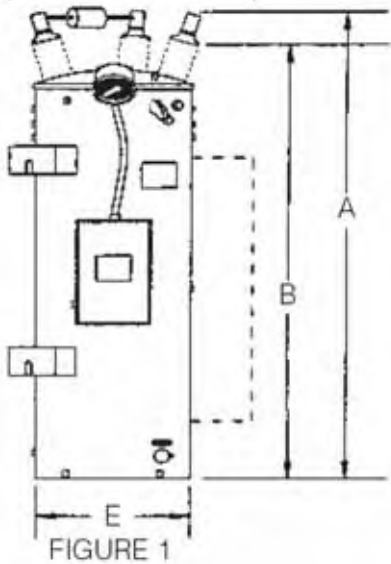
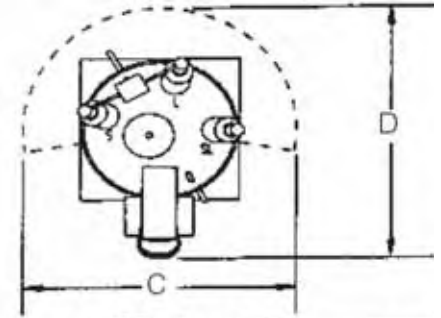
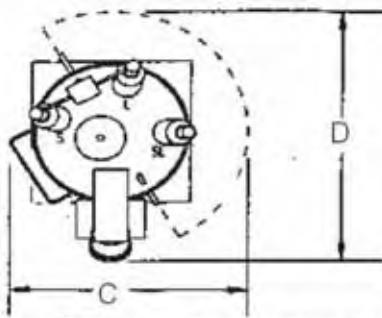
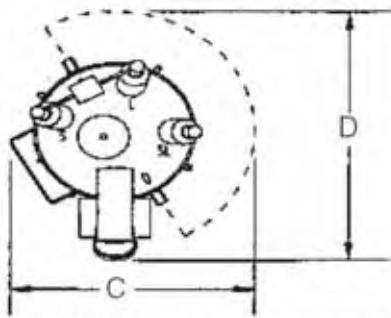

kVA	Load Current (Amps)	Figure	A	B	C	D	E	Oil (Gallons)	Untanking Weight (lbs.)	Total Weight (lbs.)
38	50	1	71	64	24	34	20	50	505	1030
57	75	1	75	68	30	39	20	55	635	1185
76	100	1	75	68	31	41	20	56	665	1265
114	150	1	75	68	35	49	22	71	785	1585
167	219	2	78	72	36	49	22	81	995	1975
250	328	2	84	78	44	56	25	100	1285	2530
333	438	3	97	91	38	61	26	153	1725	3525
416	548	3	102	96	44	61	27	210	2075	4485
500	656	3	100	93	40	67	30	224	2222	4934
667	875	3	100	97	48	68	31	247	3060	5995
833	1093	3	123	119	63	73	35	448	5620	10620



Voltage Regulator Controls

Originator: DSmith

Date: 7/11/2013

Approval: J.Nieborsky

Date: 7/11/2013

Page 1 of 1

Revision: Added CL-7, updated non-stock list

Stds Committee Approval:  
**Approved**

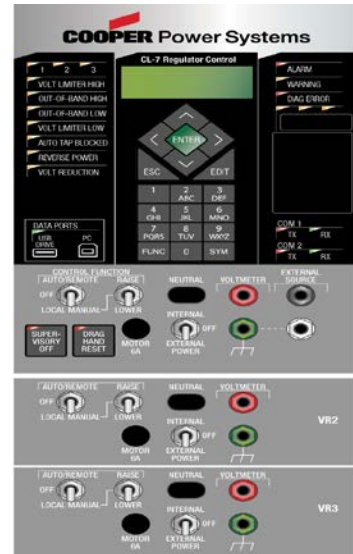

**Application:** These devices are used to control line voltage regulators and provide data for engineering. They provide for automatic +/- 10% regulation of primary voltage on the Districts distribution system.

**Specifications:** Refer to equipment specification #1211.01 for detail information.

**Approved Manufacturers: Cooper**

PUD IDENTIFICATION		MANUFACTURER CATALOG NUMBER		
Stock Description	Stock No.	Cooper	Siemens	MFG #3
Electronic Control, Regulator, Type CL-5A	088976	TBD	TBD	
Electronic Control, Regulator, Type CL-5C	088977	TBD	TBD	
Electronic Control, Regulator, Type CL-5E	088978	TBD	TBD	
Electronic Control, Regulator, Type CL-6A	088980	TBD	TBD	
Electronic Control, Regulator, Type CL-7		TBD	TBD	
Electronic Control, Siemens Old Style (Non Stock)	088981	TBD	TBD	
Electronic Control, Regulator, Type MJ-X (Non Stock)	088979	TBD	TBD	



**Single Phase 15kV Transformer  
Pole Type 25-167kVA**

Originator: DSmith

Date: 12/5/06

Approval: DSmith

Date: 6/27/2007

Page 1 of 1

Revision: **NEW**

Stds Committee Approval:  
**Approved**



**Application:** Overhead pole-type distribution transformers shall be single phase, 60 hz. mineral-oil filled and self-cooled.

**Common Name:** "Overhead POT"

**Material Specifications:** Transformers shall meet Districts Specifications #1212.01

**Size and Ratings:** The transformer shall have a kVA rating of one of the following sizes: 25, 50, 75, 100, or 167 based on not exceeding a 65°C average winding temperature rise. Transformers shall have two primary bushings and rated 95BIL.

Maximum Dimensions and Weights shall not exceed the following values.

Item Number	kVA	Secondary Voltage	Weight (lbs.)	Height* (in.)	Width (in.)**	Depth (in.)***	Secondary Terminals	Category
088816	25	120/240	375	41	23	25	Clamp	Stock
088818	50	120/240	600	45	25	27	Clamp	Stock
088819	75	120/240	875	51	25	27	Clamp	Non Stock
088820	100	120/240	1000	55	32	30	Clamp	Stock
088821	167	120/240	1600	60	38	38	4-hole spade	Min stock
088824	25	277	375	41	23	25	Clamp	Stock
088826	50	277	600	45	25	27	Clamp	Stock
088828	100	277	1000	55	32	30	Clamp	Stock
088829	167	277	1600	60	38	38	4-hole spade	Min Stock

\* Height shall be measured from bottom of tank to top of primary terminal at top of primary bushing.

\*\* Width shall be measured from lifting hook to lifting hook.

\*\*\* Depth shall be measured from mounting bracket to outside of secondary terminal.

**Stocking Category:**

1. Stock – Sufficient stocking level for normal use is carried.
2. Non Stock – No minimum stock level is carried.
3. Min Stock – Normally, only 1–3 units are carried as critical spares. Any use will trigger a reorder.

**Shipping and Identification:** Transformers shall be shipped on a pallet. A tag indicating the kVA size, manufacturer, voltage rating, serial number, actual test data and customer's purchase order number shall be attached to each unit. Units shall be shipped in a closed van so they are delivered clean and free of surface contamination.

**Marking:** The transformer nameplate shall be so labeled to indicate that at the time of manufacture the transformer liquid contained less than one part per million PCB's. Each unit shall be stenciled (2" high minimum) with the rated kVA on the lower face of the transformer.



**Single Phase 15kV Transformer  
Pad Type 25-100kVA**

Originator: DSmith

Date: 12/5/06

Approval: J. Nieborsky

Date: 12/2/2011

Page 1 of 1

Revision: **ELSP part numbers updated**

Stds Committee Approval:

**Approved**

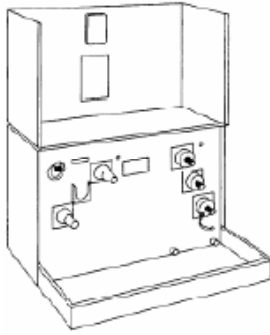

**Application:** Pad-mounted distribution transformers are used to supply single phase, 60 Hz., secondary 120/240 volt electric power

**Common Name:** "PADMOUNT"

**Material Specifications:** Transformers shall meet Districts Specifications #1212.01.

Typical Tank Dimensions:

Item #	kVA	Secondary Voltage	Weight (lbs.)	Height (in.)*	Width (in.)**	Depth (in.)***	Secondary Terminals
088888	15	240/120	650	24	33	29	Stud type – 5/8"-11UNC
088801	25	240/120	650	24	33	29	Stud type – 5/8"-11UNC
088802	50	240/120	750	24	33	32	Stud type – 5/8"-11UNC
088804	100	240/120	1150	30	36	37	Stud type – 1"-14UNC
088805	167	240/120	1300	36	36	40	Stud type – 1"-14UNC

Internal Transformer Fusing

Item #	KVA	Bay-O-Net Fuse (Dual Sensing)	Continuous Rating (Amps)	Current Limiting (ELSP Backup)	ELSP Rating
88888	15	4000358C03	3	(Isolation Link only) 3001861A01M	NA
88801	25	4000358C05	8	<b>CBUC08040C100</b>	<b>40</b>
88802	50	4000358C08	15	<b>CBUC08080C100</b>	<b>80</b>
88803	75	4000358C10	25	<b>CBUC08125C100</b>	<b>125</b>
88804	100	4000358C10	25	<b>CBUC08125C100</b>	<b>125</b>
88805	167	4000358C12	40	<b>CBUC08165D100</b>	<b>165</b>

**Shipping and Identification:** Transformers shall be shipped on a pallet, in a closed van so they are delivered clean and free of surface contamination. A tag indicating the kVA size, manufacturer, voltage rating, serial number, actual test data and customer's purchase order number shall be attached to each unit.

**Marking:** The transformer nameplate shall be so labeled to indicate that at the time of manufacture the transformer liquid contained less than one part per million PCB's. Each unit shall be stenciled (2" high minimum) with the rated kVA on the lower face of the transformer.



**TRANSFORMERS, PADMOUNT  
THREE PHASE 75-2500 kVA**

Originator: DSmith

Date: 10/16/2006

Approval: J. Nieborsky

Date: 12/2/2011

Page 1 of 1

Revision: **ELSP fuse part numbers updated**

Stds Committee Approval:

**Approved**



**Application:** Pad-mounted distribution transformers shall be three phase, 60 Hz., mineral-oil filled and self-cooled and meet Districts Specifications #1212.01.

**Size and Ratings:** Transformers shall be compartmental, pad-mounted, three phase, dead front, loop feed for use with separable high voltage connectors.

**Ratings:** The transformer shall have a kVA rating of 75, 150, 300, 500, 750, 1000, 1500, 2500kva based on not exceeding a 65 °C average winding temperature rise. The low voltage winding shall be 208Y/120 or 480Y/277 volts.

**Typical Dimensions, Does not include cooling fins.**

Item Number	kVA	Secondary Voltage	Weight (lbs.)	Height (in.)	Width (in.)	Depth (in.)	Secondary Terminals
088843	Mini-75	208Y/120	1750	36	44	51.5	Stud type – 5/8”- 11UNC
088848	150	208Y/120	2800	70	66	62	Stud type – 5/8”- 11UNC
088849	150	480Y/277	2800	70	66	62	Stud type – 5/8”- 11UNC
088853	300	208Y/277	3800	70	66	62	Stud type – 1”- 14UNC
088854	300	480Y/277	3800	70	66	62	Stud type – 5/8”- 11UNC
088856	500	208Y/120	5600	70	66	62	6-Hole Spade
088857	500	480Y/277	5600	70	66	62	6-Hole Spade
088858	750	208Y/120	7400	89	70	66	10-Hole Spade - Supported
088859	750	480Y/277	7400	89	70	66	10-Hole Spade – Supported
088861	1000	480Y/277	8200	89	70	66	10-Hole Spade – Supported
088862	1500	480Y/277	10300	89	70	66	10-Hole Spade - Supported
088876	2500	480Y/277	14100	89	70	66	10-Hole Spade - Supported

**Internal Transformer Fusing**

Stock #	Three Phase KVA	Bay-O-Net Fuse (Dual Sensing)	Continuous Ampere Rating	Current Limiting (ELSP Backup)	ELSP Ampere Rating	
088843	088845	75	4000358C05	8	<b>CBUC15030C100</b>	<b>30</b>
088848	088849	150	4000358C08	15	<b>CBUC15080C100</b>	<b>80</b>
088853	088854	300	4000358C10	25	<b>CBUC15100C100</b>	<b>100</b>
088857		500	4000358C12	50	<b>CBUC15150D100</b>	<b>150</b>
088858	088859	750	4000358C14	65	<b>CBUC15125C100*</b>	<b>250</b>
088861		1000	4000358C14	65	<b>CBUC15125C100*</b>	<b>250</b>
088862		1500	4038361C04CB	100	<b>CBUC15125C100*</b>	<b>250</b>
088863		2000	4038361C05CB	125	<b>CBUC15125C100*</b>	<b>250</b>
089007		2500	4038361C05CB	125	<b>CBUC15125C100*</b>	<b>250</b>

\* Two fuses in parallel



# UG MATERIAL

Originator: DSmith

Date: 1/23/2007

Approval: DSmith

Date: 1/23/2007

Page 1 of 1

Revision: **NEW**

Std's Committee Approval:  
**Approved**

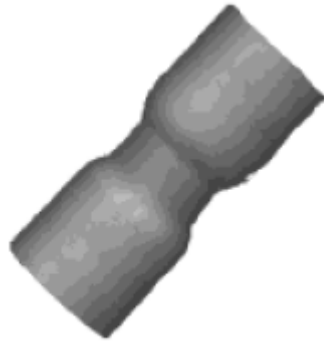

# UNDERGROUND MATERIAL







**CONDUIT, RIGID STEEL**

Originator: DSmith

Date: 7/7/06

Approval: DSmith

Date: 6/27/2007

Page 1 of 1

Revision: **NEW**

Stds Committee Approval:  
**Approved**



**Specification:**

Material: High-Strength Steel

Finish: Hot dipped galvanized, top-coated with a compatible organic layer to inhibit white rust and increase corrosion resistance.

**Packaging and Marking:** Items shall be suitably packaged to prevent damage. The container shall be convenient for handling and storage. Manufacturer's name or symbol and catalog number shall be on each part or (and) its packaging.

**Approved Manufacturers: ALL**

PUD IDENTIFICATION		MANUFACTURER CATALOG NUMBER		
Stock Description	Stock No.	MFG #1	MFG #2	MFG #3
Conduit, Rigid Steel, 2" X 10' Threaded Ends W/ One Coupling	043000	-	-	-
Conduit, Rigid Steel, 2-1/2" X 10' Threaded Ends W/ One Coupling	043020	-	-	-
Conduit, Rigid Steel, 3" X 10' Threaded Ends W/ One Coupling	043040	-	-	-
Conduit, Rigid Steel, 3-1/2" X 10' Threaded Ends W/ One Coupling	043060	-	-	-
Conduit, Rigid Steel, 4" X 10' Threaded Ends W/ One Coupling	043080	-	-	-
Conduit, Rigid Steel, 5" X 10' Threaded Ends W/ One Coupling	043100	-	-	-
Conduit, Rigid Steel, 6" X 10' Threaded Ends W/ One Coupling	043120	-	-	-





**CONDUIT, FLEXIBLE METAL**

Originator: DSmith

Date: 7/19/2006

Approval: DSmith

Date: 6/27/2007

Page 1 of 1

Revision: **NEW**

Stds Committee Approval:  
**Approved**



**Application:** Used in place of rigid steel or rigid PVC.

**Common Name:** SealTite

**Packaging and Marking:** Items shall be suitably packaged to prevent damage. The container shall be convenient for handling and storage. Manufacturer's name or symbol and catalog number shall be on each part or (and) its packaging.

**Shipping:** None

**Approved Manufacturers: ALL**

PUD IDENTIFICATION		MANUFACTURER CATALOG NUMBER		
Stock Description	Stock No.	MFG #1	MFG #3	MFG #3
CONNECTOR, SEALTITE, FLEX	015810	XXXXX	XXXXX	XXXXX
CONNECTOR, STRAIGHT 2", LIQUID	140543	XXXXX	XXXXX	XXXXX



**CHANNEL STRUT, FITTINGS, CLAMPS**

Originator: DSmith

Date: 7/7/06

Approval: J Mitchell

Date: 8/17/11

Revision:

Stds Committee Approval: **Approved**

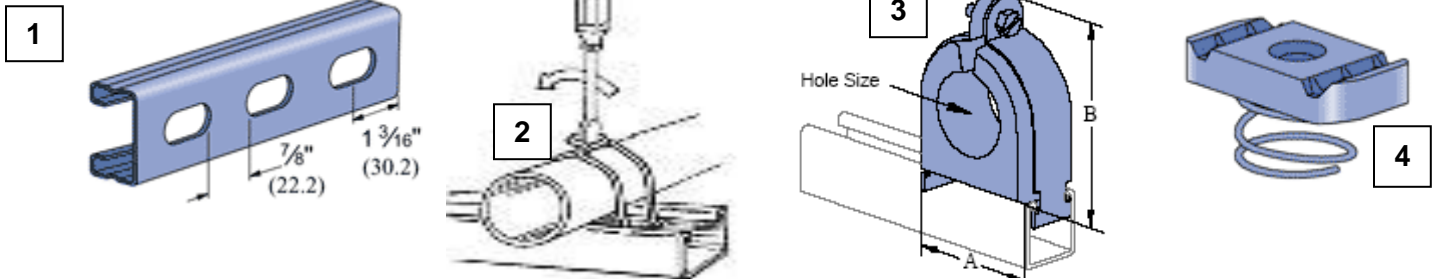

<b>BOLT SIZE</b>	1/4"	5/16"	3/8"	1/2"	5/8"	3/4"
	20	18	16	13	11	10
<b>FOOT LBS.</b>	6	11	19	50	100	125
<b>N·m</b>	8	15	25	70	135	170

**Approved Manufactures**

PUD IDENTIFICATION			MANUFACTURER CATALOG NUMBER			
Stock Description	Stock #	Figure #	Unistrut	Kindorf	Powerstrut	Cooper B-Line
STRUT, CHANNEL, 1-5/8" X 13/16" SLOTTED	050500	1	P4000T	XXXXX		
CLAMP, CONDUIT, 1" GALV	042440	2		P200-1		
CLAMP, CONDUIT, 2" GALV	042450	2		P200-2		
CLAMP, CONDUIT, 2-1/2" GALV	042460	2		P200-21/2		
CLAMP, CONDUIT, 3" GALV	042470	2		P200-3		
CLAMP, CONDUIT, 3-1/2" GALV	042480	2	P1120			
CLAMP, CONDUIT, 4" GALV	042490	2		P200-4		
CLAMP, CONDUIT, 5" GALV	042500	2	P1123	P-200-5		
CLAMP & CUSHION ASSEMBLY, #2 PRIMARY CABLE	050750	3			PS-7221EV	
CLAMP & CUSHION ASSEMBLY, #4/0 PRIMARY CABLE	050760	3			PS-722112EV	
CLAMP & CUSHION ASSEMBLY, 350 ALUM, 1/C 600 VOLT CABLE	050765	3			PS-7223/4	
CLAMP & CUSHION ASSEMBLY, 750KCM PRIMARY CABLE	050770	3			PS-7221/8	
CLAMP & CUSHION ASSEMBLY, 1000 KCM PRIMARY CABLE	050780	3			PS-722212EV	
CHANNEL NUTS W/ SPRING 1/4" - 20 (1-5/8" Series)	050652	4	P4006-1420			N524
CHANNEL NUTS W/ SPRING 3/8" -16 (1-5/8" Series)	050650	4	P4008			N528
CHANNEL NUTS W/ SPRING 1/2" -13 (1-5/8" Series)	140752	4	P4009			N525



**CONDUIT, PVC, SCHEDULE 40/80**

Originator: DSmith

Date: 7/12/2006

Approval: DSmith

Date: 8/21/2007

Page 1 of 1

Revision: **NEW**

Stds Committee Approval:  
**Approved**

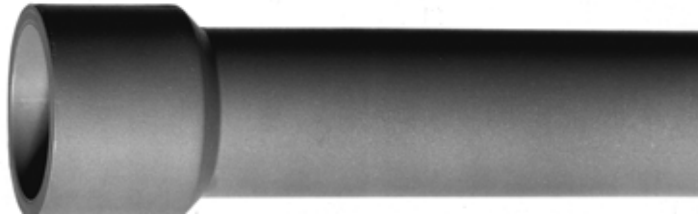

**Application:** PVC (Polyvinyl Chloride) conduit is used where primary or secondary cable is buried below streets, patios, and other large concrete or asphalt areas which would make access to the cable difficult for future repairs. Schedule 40 PVC is also used for pole risers.

**Specification:** The conduit shall be made of POLYVINYL CHLORIDE and utility gray in color. It shall be resistant to sunlight and UL Listed for exposed or outdoor usage. This conduit shall meet or exceed the following standards and tests. NEMA standard TC-2, UL listing UL-651, ASTM test method D1598, dimensional requirements of ASTM d 1785 and the joint specifications of ASTM d 2672-96a. (the socket length in inches shall comply with table 1 Tapered sockets for bell-end pipe column "c" pressure). Rated for 90 degree C conductor.

**Packaging & Marking:** Items shall be suitably packaged to prevent damage. The container shall be convenient for handling and storage. At a minimum, lifts of conduit must be framed with at least 2" x 4" dimensional lumber. Duct shall be clearly marked with manufacturer's name or trademark, nominal size, material (PVC) and NEMA type.

**Approved Manufacturers:** Royal Pipe, Carlon, Pw Pipe, Can-Tex, Carlon, J - M Manufacturing

PUD IDENTIFICATION	
Stock No.	Stock Description
043378	Conduit, Gray PVC, 3/4" X 10' Sch 40 W/One Bell End
043380	Conduit, Gray PVC, 2" X 10' Sch 40 W/One Bell End
043381	Conduit, Gray PVC, 2" X 20' Sch 40 W/One Bell End
043400	Conduit, Gray PVC, 2 1/2" X 20' Sch 40 W/One Bell End
043420	Conduit, Gray PVC, 3" X 10' Sch 40 W/One Bell End
043421	Conduit, Gray PVC, 3" X 20' Sch 40 W/One Bell End
043440	Conduit, Gray PVC, 3-1/2" X 10' Sch 40 W/One Bell End
043460	Conduit, Gray PVC, 4" X 10' Sch 40 W/One Bell End
043480	Conduit, Gray PVC, 5" X 10' Sch 40 W/One Bell End
043484	Conduit, Gray PVC, 5" X 20' Sch 40 W/One Bell End
043500	Conduit, Gray PVC, 6" X 10' Sch 40 W/One Bell End
043520	Conduit, Gray PVC, 2" X 10' Sch 80 W/One Bell End
043540	Conduit, Gray PVC, 3" X 10' Sch 80 W/One Bell End
043550	Conduit, Gray PVC, 4" X 10' Sch 80 W/One Bell End
043560	Conduit, Gray PVC, 5" X 10' Sch 80 W/One Bell End



**PVC FITTINGS, SCHEDULE 40/80**

Originator: DSmith

Date: 7/7/06

Approval: DSmith

Date: 7/7/06

Page 1 of 1

Revision: **NEW**

Stds Committee Approval:  
**Approved**

1



2



3



4



PUD IDENTIFICATION			MANUFACTURERS CATALOG #		
Stock Description	Stock #	Fig #	PW Pipe	CARLON	Misc
Coupling, SCH 40 Gray PVC, 2-1/2" SCH 40, Deep Socket	044551	1		E940K	
Coupling, SCH 40 Gray PVC, 2" (Extra Long), Length 5.5"	044550	1	600202003		RACEWAY AVRTCUL020
Coupling, SCH 40 Gray PVC, 3" (Extra Long), Length 8.5"	044552	1	600203003		
Coupling, SCH 40 Gray PVC, 4" (Extra Long), Length 7.5"	044554	1	600204003		RACEWAY AVRTCUL040
Coupling PVC 5" SCH 40 Extra Long	044555	1			
Coupling PVC 6" SCH 40 Extra Long	044553	1			
Fitting, End Bell, 2" SCH 40	040710	2		E297J	
Fitting, End Bell, 2-1/2" SCH 40	040711	2		E997K	
Fitting, End Bell, 3" SCH 40	040712	2		E997L	KRALOY #MEB30
Fitting, End Bell, 4" SCH 40	040714	2		E997N	
Fitting, End Bell, 5" SCH 40	040715	2		E997P	
Fitting, End Bell, 6" SCH 40	040713	2		-	
Adapter, SCH 40 Gray PVC, Female, 2" To Rigid	040600	3		E942J	KRALOY FA 20
Adapter, SCH 40 Gray PVC, Female, 2 1/2" To Rigid	040610	3		E942K	KRALOY FA 25
Adapter, SCH 40 Gray PVC, Female, 3" To Rigid	040620	3		E942L	KRALOY FA 30
Adapter, SCH 40 Gray PVC, Female, 3 1/2" To Rigid	040630	3		E942M	KRALOY FA 35
Adapter, SCH 40 Gray PVC, Female, 4" To Rigid	040640	3		E942N	KRALOY FA 40
Adapter, SCH 40 Gray PVC, Female, 5" To Rigid	040650	3		E942P	KRALOY FA 50
Adapter, SCH 40 Gray PVC, Male, 2"	044510	3			CED - PVC Ta2
Adapter SCH 40, 2" Gray PVC, Slip To Outside Threaded End	044515	3			CED- BPT 326
Coupling, Reducer, 3" To 2 1/2" SCH 40, PVC	044609	4			
Coupling, Reducer, 3" To 2" SCH 40, PVC	044607	4			
Coupler, Sherlock II, W/ SS Pipe Clamps Fits OD Size 2.355 To 2.395	049480				Arnco NCO 18003217914



**CONDUIT, FLEXIBLE PVC**

Originator: DSmith

Date: 7/7/06

Approval: DSmith

Date: 6/27/2007

Page 1 of 1

Revision: **NEW**

Stds Committee Approval:  
**Approved**

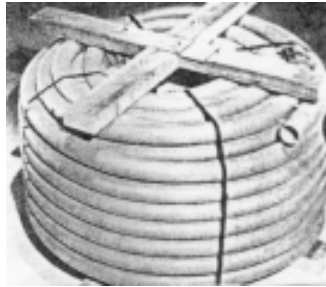

**Application:** PVC (polyvinyl chloride) power duct is for encasing power cable in direct burial applications where flexible duct is needed.

**CAUTION:** Care should be taken when installing conductor in flexible duct, duct walls are thin and are easily worn through.

**Ordering Description:** (Size) Flexible PVC plastic conduit.

Duct shall be:

- PVC, gray in color, per NEMA standard TC-12
- suitable for use with 90 deg. C cable in wet or dry locations.

**Packaging & Marking:** Items shall be suitably packaged to prevent damage. The container shall be convenient for handling and storage. Manufacturer's name or symbol and catalog number shall be on each part and its packaging.

**Approved Manufacturers**

PUD IDENTIFICATION		MANUFACTURER'S CATALOG NUMBER		
Stock Description	Stock No.	Carlton	Can-Tex	Kaf-flex
CONDUIT, PVC FLEX 2" x 250' ROLL	042720	11811-250	A90CAG1	8436
CONDUIT, PVC FLEX 2 1/2" x 250' ROLL	042725	11812-250	-----	-----
CONDUIT, PVC 3" x 250' ROLL	042730	11813-250	-----	-----



**CONDUIT, 36" ADS PIPE**

Originator: DSmith

Date: 7/7/06

Approval: DSmith

Date: 6/27/2007

Page 1 of 1

Revision: **NEW**

Stds Committee Approval:  
**Approved**



**Application:**

**Common Name:** ADS pipe

**Ordering Description:** N12 36"x20' SOLID A.D.S. PIPE

Dimensions: 36" x 20'

Material: High Density Polyethylene

**Packaging and Marking:** Items shall be suitably packaged to prevent damage. The container shall be convenient for handling and storage. Manufacturer's name or symbol and catalog number shall be on each part or (and) its packaging.

**Approved Manufacturers:**

PUD IDENTIFICATION		MANUFACTURER CATALOG NUMBER
Stock Description	Stock No.	United Pipe
Conduit, 36"X20' ADS Pipe, Black Ribbed	043510	024665





# CONDUIT, PVC SWEEP ELBOWS

Originator: DSmith

Date: 7/19/2006

Approval: DSmith

Date: 12/3/2007

Page 1 of 2

Revision: added 2" 24" radius elbow.

Stds Committee Approval:  
**Approved**



**Application:** PVC (Polyvinyl Chloride) conduit elbows (sweeps) are used to transition from horizontal to vertical such as riser poles, termination cabinets, etc for primary or secondary cable.

**Specification:** The elbows shall be made of POLYVINYL CHLORIDE and utility GRAY or Orange in color as identified in the description. This conduit shall meet or exceed the following standards and tests. NEMA standard TC-2, UL listing UL-651, ASTM test method D1598, dimensional requirements of ASTM d 1785 and the joint specifications of ASTM d 2672-96a. (The socket length in inches shall comply with table 1 Tapered sockets for bell-end pipe column "c" pressure). Rated for 90 degree C conductor.

**Approved Manufacturers:** Royal Pipe, Carlon, PW Pipe, Can-Tex, J - M Manufacturing

**Packaging and Marking:** Items shall be suitably packaged to prevent damage. The container shall be convenient for handling and storage. Manufacturer's name or symbol and catalog number shall be on each part or (and) its packaging.

ITEMNUM	MAXIMO DESCRIPTION
<b>ELECTRIC</b>	
044806	ELBOW, 2" SCH 40 GRAY PVC CONDUIT, 90 DEGREE, 24" RADIUS W/ONE BELL END
044810	ELBOW, 2" SCH 40 GRAY PVC CONDUIT, 90 DEGREE, 36" RADIUS W/ONE BELL END
044830	ELBOW, 2 1/2", SCH 40 GRAY PVC CONDUIT, 90 DEGREE, 36 " RADIUS W/ONE BELL END
044821	ELBOW, 2", SCH 40 GRAY PVC CONDUIT, 22 1/2 DEGREE, 48" RADIUS W/ONE BELL END
044820	ELBOW, 2", SCH 40 GRAY PVC CONDUIT, 45 DEGREE, 36" RADIUS W/ONE BELL END
049625	ELBOW, 2", SCH 40 GRAY PVC CONDUIT, 90 DEGREE, 60" RADIUS W/ONE BELL END
044766	ELBOW, 3", SCH 40 GRAY PVC CONDUIT, 22 1/2 DEGREE, 36" RADIUS W/ONE BELL END
044765	ELBOW, 3", SCH 40 GRAY PVC CONDUIT, 45 DEGREE, 36" RADIUS W/ONE BELL END
044760	ELBOW, 3", SCH 40 GRAY PVC CONDUIT, 90 DEGREE, 36" RADIUS W/ONE BELL END
049440	ELBOW, 3", SCH 40 GRAY PVC CONDUIT, 90 DEGREE, 60" RADIUS W/ONE BELL END
044840	ELBOW, 4", SCH 40 GRAY PVC CONDUIT, 22 1/2 DEGREE, 36" RADIUS W/ONE BELL END
044880	ELBOW, 4", SCH 40 GRAY PVC CONDUIT, 45 DEGREE, 36" RADIUS W/ONE BELL END
044770	ELBOW, 4", SCH 40 GRAY PVC CONDUIT, 90 DEGREE, 36" RADIUS W/ONE BELL END
044775	ELBOW, 4", SCH 40 GRAY PVC CONDUIT, 90 DEGREE, 60" RADIUS W/ONE BELL END





**CONDUIT, PVC SWEEP ELBOWS**

Originator: DSmith

Date: 7/19/2006

Approval: DSmith

Date: 12/3/2007

Revision: added 2" 24" radius elbow.

Stds Committee Approval:

**Approved**

ITEMNUM	MAXIMO DESCRIPTION
044800	ELBOW, 5", SCH 40 GRAY PVC CONDUIT, 45 DEGREE, 48" RADIUS W/ONE BELL END
044790	ELBOW, 5", SCH 40 GRAY PVC CONDUIT, 90 DEGREE, 48" RADIUS W/ONE BELL END
044895	ELBOW, 5", SCH 40 GRAY PVC CONDUIT, 90 DEGREE, 60" RADIUS W/ONE BELL END
044860	ELBOW, 6", SCH 40 GRAY PVC CONDUIT, 45 DEGREE, 48" RADIUS W/ONE BELL END
044850	ELBOW, 6", SCH 40 GRAY PVC CONDUIT, 90 DEGREE, 48" RADIUS W/ONE BELL END

**FIBER**

044805	ELBOW, 1" SCH 40 ORANGE PVC CONDUIT, 90 DEGREE, 36" RADIUS (FIBER INDIVIDUAL SERVICES)
044815	ELBOW, 2" SCH 40 ORANGE PVC CONDUIT, 45 DEGREE, 36" RADIUS, (FOR FIBER)
044808	ELBOW, 2" SCH 40 ORANGE PVC CONDUIT, 90 DEGREE, 36" RADIUS
060089	ELBOW, 2" SCH 40, REPAIR, 36R 90 DEGREE,GRAY, ( FIBER )
060098	ELBOW, 4" SCH 40, 36R 90 DEGREE,GRAY,NOTCHED,WITH VINYL SEALING STRIP ( FIBER )



### CONDUIT SEALING KITS Cable Breakouts

Originator: DSmith

Date: 7/7/06

Approval: DSmith

Date: 6/27/2007

Page 1 of 1

Revision: **NEW**

Stds Committee Approval:  
**Approved**

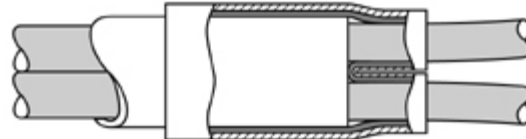

**Application:** URayChem sed to seal the end of conduits when multiple conductors are installed.

**Common Name:** Cow Udders

**Specification:** These seals shall be made crosslinked polyolefin to provide mechanical protection and strain relief. These seals shall have an adhesive-coating on the body and the legs to form a durable watertight seal, and conform tightly to conduits and cable jackets.

Qualified to ANSI/IEEE C119.1-1986.

**Packaging and Marking:** Items shall be suitably packaged to prevent damage. The container shall be convenient for handling and storage. Manufacturer's name or symbol and catalog number shall be on each part or (and) its packaging.

**Approved Manufacturers:**

PUD IDENTIFICATION		MANUFACTURER CATALOG NUMBER
Stock Description	Stock No.	Raychem
CONDUIT SEALING KIT, 3 POSITION	041756	CBR-6-1-A
CONDUIT SEALING KIT, 6 POSITION	041755	CBR-3-3-A



**Conduit Duct Spacers  
Underground**

Originator: DSmith

Date: 7/9/2007

Approval: DSmith

Date: 7/9/2007

Page 1 of 1

Revision: **NEW**

Stds Committee Approval:  
**Approved**

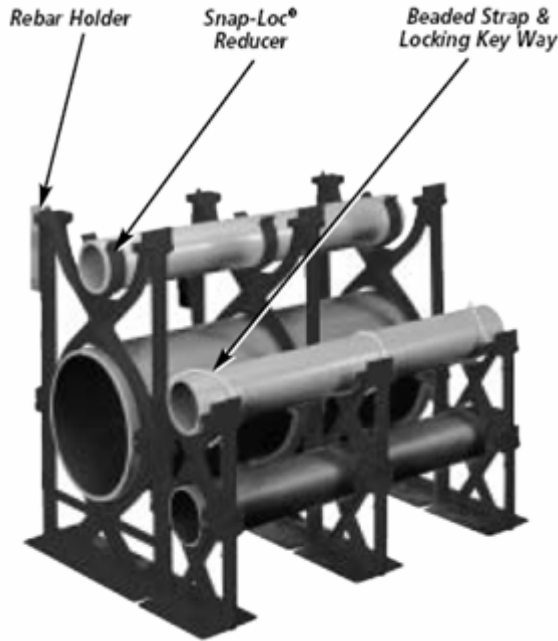

**Figure 1**



**Figure 2**

**Application:** **Underground Conduit Duct Spacers** are designed to be used in concrete encased applications only. The system consist of either a base unit and an intermidiate unit that snap together or a one piece dual conduit unit.

The use of duct spacers for direct burial may result in excessive point deflections unless proper compaction of the appropriate backfill material. Direct burial installation is not recommended by the manufacture.

**Specifications:**

Each unit shall be manufactured out of highly engineered thermoplastic material and shall be specifically designed to withstand the rigors of concrete construction.

**Approved Manufacturers: Carlon**

PUD IDENTIFICATION			MANUF CATALOG NUMBER
Stock No.	Stock Description	Fig	Carlon
042715	Conduit Spacer, Base, 3" PVC Conduit Racking	1	S288LLN
042716	Conduit Spacer, Intermediate, 3" PVC Conduit Racking	1	S289LLN
Under review	Conduit Spacer, One Piece 3 inch Spacing for 3" PVC Conduit Racking	2	SP3W30-2



**CONDUIT SEALING PLUG**

Originator: DSmith

Date: 7/7/06

Approval: DSmith

Date: 8/3/2007

Page 1 of 1

Revision: **NEW**

Stds Committee Approval:  
**Approved**



**Application:** Used for the temporarily plugging of duct, bell-ends and terminators. These polyethylene plugs come in sizes to fit all types of manufactured duct, even when it's bell ended or coupling is attached. The universal plugs extended lip design permits easy extraction.

**Specification:** Each plug is made polyethylene.

**Packaging and Marking:** Items shall be suitably packaged to prevent damage. The container shall be convenient for handling and storage. Manufacturer's name or symbol and catalog number, applicable size and color code shall be on each part.

**Approved Manufacturers:**

PUD IDENTIFICATION		MANUFACTURER CATALOG NUMBER		
Stock Description	Stock No.	CONDUX	CARLON	CANTEX
Conduit Duct Plug – 2 inch	044602	08047400	P258JT	5315248
Conduit Duct Plug – 3 inch	044603	08047500	P258LT	5315250



**SPLIT RING GRIPS**

Originator: Jeff Mitchell

Date: 7/27/2012

Approval: Jeff Mitchell

Date: 7/27/2012



**Rod Closing**

**Application:** Split ring grips are used for cable suspension and can be installed on the conductor inside conduit without having either end of the conductor. Installation is accomplished by wrapping the grip around the desired position on the conductor and securing the basket by twisting rod through the closing rings on the basket.

**Common Name:** Split Ring Grip

**Packaging and Marking:** Items shall be suitably packaged to prevent damage. The container shall be convenient for handling and storage. Manufacturer's name or symbol and catalog number shall be on each part or (and) its packaging.

**Approved Manufacturers:**

PUD IDENTIFICATION		
Stock Description	Stock No.	LEWIS
GRIP, 3" SPLIT RING, CABLE SUPPORT, ROD CLOSING, FOR 750/1000KCM UG CABLE	045492	LRSR-2-1.0
GRIP, 2" SPLIT RING, CABLE SUPPORT, ROD CLOSING, FOR #2 PRIMARY UG CABLE	045494	LRSR-3-2.0



**FIBERGLASS HANDHOLES,  
PEDESTAL AND BURIED**

Originator: DSmith

Date: 7/7/06

Approval: J. Mitchell

Date: 5/20/2014

Page 1 of 1

Revision: **Added fiber optic handhole**

Stds Committee Approval:  
**9/22/06**

**Application:** These fiberglass boxes are used for splice and pull boxes for the District's electric and fiber cable. Boxes and covers are for locations that are non-traffic or may have an occasional, non-deliberate vehicle exposure. Cover is rated for a maximum of 5,000 lbs.

**Features:** These units are molded of high density polyethylene. A flange around the base prevents frost from heaving or tilting. Units can be nested for a minimum amount of warehouse storage space. All units are molded in green color.

The handhole lid shall be secured by a sliding metal latch on one end and a double locking mechanism on the other end. The double locking mechanism shall consist of a 3/8-16 penta head bolt and accommodations for a crimp type lock. In addition a horseshoe cutout is required at the penta head lock area for drainage.

Handhole shall be equipped with a recess in lid for attaching an ID number and the following words shall be molded into the lid depending on its application with a minimum of 1 ¼ inch high letters.

**CCPUD  
ELECTRIC**

Or

**CCPUD  
FIBER**

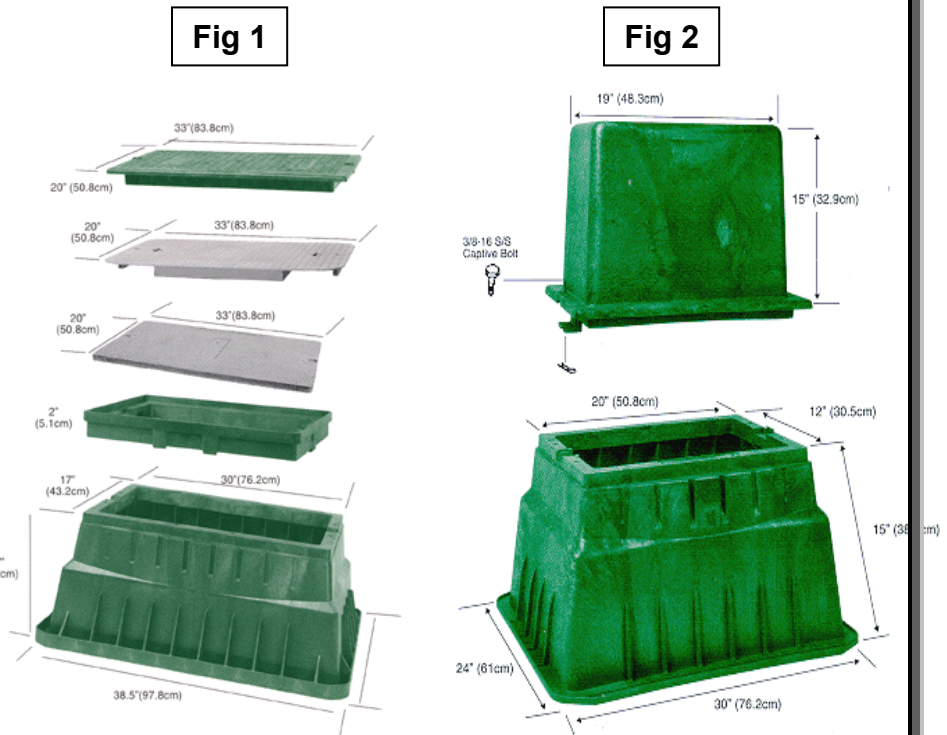

Description	Fig	Item #	Dimensions - Inches	Approved Manufacturers:
				<b>Pencell</b>
Handhole, Buried Pedestal, Fiberglass	1	045600	38.5"Lx25.5"Wx17"H	PE30HDXCL - CHELAN
Handhole, Above Grade Pedestal, Fiberglass	2	045450	BASE: 30"Lx24"Wx15"H PEDESTAL:19"Lx12"W x15"H	AG20HDXCL
Handhole, Fiber Optic	1	060033	38.5"L x 25.5"W X 17"H	PE30HDXCL-FIBER



### Fiberglass Box Pads For Single Phase Transformers

Originator: D Smith

Date: 6/28/2007

Approval: J Mitchell

Date: 02/06/2013

Page 1 of 1

Revision: **Removed Highline due to lack of reinforcement**

Stds Committee Approval: **9/22/06**



**Application:** Used to provide a foundation for Single Phase Pad Mounted Transformers from 25 KVA up to 167 KVA.

Covers are used to protect the public from open transformer pads prior to the installation of transformers. See note 7.

**Minimum Specifications:**

Stock No.	Used For	Top	Opening	Capacity
046550	All Single Phase Padmount Transformers	42X38X30"	24" W x 22" D	

1. Fiberglass Transformer Box Pads shall be constructed of high-strength FRP laminate to meet Western Underground Guidelines. The laminate shall be applied to a gel-coated female mold.
2. Exterior color: Munsell #7GY3.29/1.5 Green
3. One and a half-ounce random fiber chopped fiberglass and resin will be the initial coating, followed by alternate layers of 24-ounce woven roving and chopped fiberglass.
4. The product shall meet a Class 2 flame retardant rating. Aluminum Tri-Hydrate is permitted as a filler only to a maximum loading of 43%. Glass content of the finished laminate shall not be less than 33%.
5. Each unit shall be supplied with four 4.5 Inch X 1.5 inch hold down cleats with stainless steel inserts and brass bolts installed loosely on each unit.
6. The perimeter base lip shall be a minimum of 4-1/2" for stability.
7. Cover shall be supplied with penta-head bolts for fastening to box pad.

**Packaging, Marking & Shipping:** Items shall be suitably packaged to prevent damage. Manufacturer's name or symbol and catalog number shall be on each part or (and) its packaging. Units shall be shipped stacked on wooden pallets, no more than six feet high.

**Approved Manufactures:**

PUD IDENTIFICATION		MANUFACTURER CATALOG NUMBER		
Stock Description	Stock No.	PROGLASS	HIGHLINE	NORDIC
PAD, FIBERGLASS BOX, TXFMR, TOP 42" X 38", HEIGHT 30", BOT 54" X 50"	046550	TX423830TI		GS-37-43-32C-CE-CHELAN
COVER, FIBERGLASS, ( FOR NORDIC ONLY FIBERGLASS SLEEVE STK# 046550 )	046555			GSC-37-43





**PAD, HILL HOLDER, FIBERGLASS**

Originator: DSmith

Date: 7/7/06

Approval: DSmith

Date: 7/9/2007

Page 1 of 1

Revision: **NEW**

Stds Committee Approval:  
**Approved**

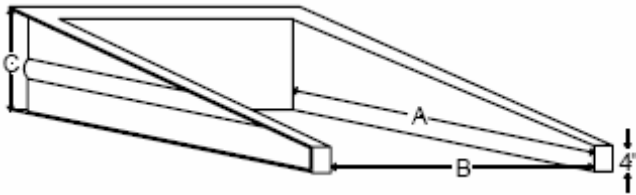

**Application:** Hill Holders are placed behind a pad-mount equipment situated on a hill. Hill Holders help hold back gravity induced soil movement. In addition they prevent corrosion and other damage by blocking dirt and rocks from falling on or against the back and sides of the equipment.

**Specification:** Each unit shall be produced in a female mold of fire retardant double layers of 24 oz woven roving reinforcement cloth with a C-type fiberglass and resin mix. The exterior finish shall be covered with a smooth Munsell Green gel-coat, which contains UV stabilizer for superior weatherability.

**Packaging and Marking:** Items shall be suitably packaged to prevent damage. The container shall be convenient for handling and storage. Manufacturer's name or symbol and catalog number shall be on each part or (and) its packaging.

**Approved Manufacturers:**

PUD IDENTIFICATION		MANUFACTURER CATALOG NUMBER	
Stock Description	Stock No.	PROGLASS	Mfg #2
Hill Holder, Fiberglass, For Transformer, One Piece, 54.5"W X 36"H, 50.5" Depth	045655	HB365450	
Hill Holder, Fiberglass, For Three Phase Termination Cabinets, One Piece, 72"W X 36"H, 50.5" Depth	045658	HB367250	

**- Material Specification -**

**UG**

**1313.00**

CHELAN COUNTY  
**PUBLIC UTILITY DISTRICT**  
*Owned By The People We Serve*



**T&D UG VAULTS & COVERS**  
**PRECAST CONCRETE**  
**- Self Grounding -**

Originator: DSmith

Date: 2/27/2009

Approval: DSmith

Date: 2/27/2009

Page 1 of 7

Revision: **NEW**

Stds Committee Approval:  
**APPROVED**



**Chelan County Public Utility District**  
**PO Box 1231**  
**Wenatchee, WA. 98807-1231**  
**(509) 661-4686**  
**Revised 2/27/2009**



**T&D UG VAULTS & COVERS**  
**PRECAST CONCRETE**  
**- Self Grounding -**

Originator: DSmith

Date: 2/27/2009

Approval: DSmith

Date: 2/27/2009

Page 2 of 7

Revision: **NEW**

Stds Committee Approval:  
**APPROVED**

**1. SCOPE**

The technical provisions of this specification detail the minimum performance criteria and physical requirements for the concrete junction boxes, switch boxes, transformer vaults and covers to be used in the construction of underground electrical systems.

**1.1. Third Party Purchases**

The technical provisions of this specification apply to those units purchased directly by Chelan PUD and those units sold to third parties for use by Chelan PUD.

**2. APPROVAL**

All construction drawings used in the manufacturing of the concrete junction boxes, switch boxes, transformer vaults and covers will be reviewed by Chelan PUD before construction/manufacturing begins.

**3. STRUCTURAL**

Underground distribution concrete junction boxes, switch boxes, transformer vaults and covers of this specification shall meet the following minimum requirements.

**3.1. CONCRETE**

The concrete used shall have a minimum 28 day compressive strength (f'c) = 6000 PSI.

**3.2. REINFORCEMENT**

All units shall be reinforced with a minimum grade 60 welded wire fabric and #3 - #8 grade 60 bars.

**3.3. DESIGN LOADING**

All units shall be constructed for H-20 wheel loads or better with a 30% impact factor.

**3.4. UNISTRUTS**

Unistruts shall be provided and centered per enclosed applicable Chelan PUD T&D Vault and Cover Standards. The Unistrut size shall be 1 5/8" x 13/16" x 36" minimum length. All Unistrut material shall be hot-dipped galvanized.

**4. INTERNALLY GROUNDED VAULTS**

Chelan PUD is using internally grounded vaults for junctions, transformer and switch installations. The general requirement will be to bond all internal metallic structures



**T&D UG VAULTS & COVERS**  
**PRECAST CONCRETE**  
**- Self Grounding -**

Originator: DSmith

Date: 2/27/2009

Approval: DSmith

Date: 2/27/2009

Page 3 of 7

Revision: **NEW**

Stds Committee Approval:  
**APPROVED**

together to a bronze insert. This grounding procedure shall meet the provisions of NESC Rule 94B6

4.1. ELECTRODES

Grounding electrodes shall be as shown on attached drawings and:

SPECIFICATION	REBAR
Minimum length	22 feet
Minimum size	# 3 - 3/8"

4.1.1. Installation

- The Electrodes shall be installed as straight as possible.
- The Electrodes shall be encased with a minimum of 1½" of radial concrete.
- The Electrodes shall be a minimum of 2.5' below the top of the vault or junction box.

4.1.2. Ground Insert Connector

Each bronze insert will be tapped for 1/2"-13 bolt, and located 2 inches below the Unistrut and in the middle of two opposite side walls (two inserts per wall, one faces inside the vault the other faces outside the vault) as shown in the attached Standard Drawings. A 3/8-inch steel rod, or similar sized metallic conductor, shall be used to bond the inserts to the structural steel in the concrete. The inserts shall be plugged to prevent contamination from entering.

On multi-sectioned vaults, the inserts shall be vertically aligned. Only the middle section will have the inserts that face inside the vault and outside the vault, all other inserts in these vaults will be placed as shown in the attached standard for that type vault.

4.1.2.1- Bonding to rebar and Wire Mesh

Ground insert connectors shall be electrically bonded to rebar and wire mesh by welded connections in a minimum of two locations



**T&D UG VAULTS & COVERS**  
**PRECAST CONCRETE**  
**- Self Grounding -**

Originator: DSmith

Date: 2/27/2009

Approval: DSmith

Date: 2/27/2009

Revision: **NEW**

Stds Committee Approval:  
**APPROVED**

4.1.2.2 – Labeling of Inserts

Inserts shall be labeled / identified in **Green Paint** as follows:

Section	Label
Base (Section that includes the minimum of 22 ft. of #3 Rebar bonded to insert)	<b>GRND</b>
Cover	<b>BOND</b>
Mid-Section	<b>BOND</b>

The labeling shall be adjacent to the insert. When inserts on covers are oriented downward the label shall be painted on the access opening side closest to the insert location.

**5. COVERS**

**5.1. GROUNDING INSERTS**

All covers shall have grounding inserts installed per manufacturer’s and Chelan PUD’s specification. Each insert shall be bonded to the wire mesh used as reinforcement in the cover. The location is shown on the drawings, for each unit, included with this specification.

**5.2. METALLIC COVERS**

The 36” x 36” cover(s) shall be designed for AASHTO H20 loading, as specified, and shall have two 180-degree flush hinges, lifting handle(s), and concealed locking device(s). A Penta head bolt in a recessed, non-rotating cup is to be part of the required locking device. (See Figure 1, ANSI C57.12.28.1988, for typical installation). The lid shall be manufactured from a skid resistant surface, hot-dipped galvanized steel and be provided with spring-assisted opening and closing requiring a 55-pound maximum effort to open and close it. As an alternate, an aluminum lid may be supplied subject to Chelan PUD’s approval. If supplied, it must meet all the applicable requirements above.

**5.3. COVER, TRANSFORMER VAULT**

The transformer vault lids shall have blockouts as described in the attached material standard for each type vault.

**5.3.1. LOGO “CHELAN PUD”**

All covers shall have the logo “**CHELAN PUD**” cast into the concrete structure using minimum two-inch-high letters. The logo is to be legible after 20 years



**T&D UG VAULTS & COVERS**  
**PRECAST CONCRETE**  
**- Self Grounding -**

Originator: DSmith

Date: 2/27/2009

Approval: DSmith

Date: 2/27/2009

Page 5 of 7

Revision: **NEW**

Stds Committee Approval:  
**APPROVED**

exposure and placement such as to be easily noticed by a lay person casually inspecting the structure.

**6. LIFTING METHOD**

Lifting provisions shall be installed per manufacturer's and Chelan PUD's requirements.

**6.1. COVERS**

**6.1.1. Burke Fittings**

All vault covers supplied shall have a Burke fitting placed in each corner of the top according to manufacturer's standards.

**6.1.2. Strap Lifting Notch 554 And 575 Vaults Only**

All 554 and 575 covers supplied shall have a "Strap Lifting Notch" cast in the vault side of the cover in each corner. The triangular notch shall have three (3) inch sides and be ¼ inch high.

**6.1.3. LOWER UNIT**

**6.1.3.1. 554 And 575 Units**

These units shall have two (2) ton Rigging/Lifting fittings placed in each corner per manufacturer's specifications and approved by Chelan PUD.

**6.1.3.2. 612 And 810 Units**

These units shall have four (4) ton Rigging/Lifting fittings placed in each corner per manufacturer's specifications and approved by Chelan County PUD.

**7. ACCESSORIES**

Items to be included with each type vault.

**7.1. SUMP**

A sump shall be provided in the bottom of each vault. The size and placement of the sump shall be as shown in the manufacturer's catalog and approved by Chelan PUD. The bottom of the sump shall be designed such that it can be knocked out if desired.

**7.2. KNOCKOUTS**



**T&D UG VAULTS & COVERS**  
**PRECAST CONCRETE**  
**- Self Grounding -**

Originator: DSmith

Date: 2/27/2009

Approval: DSmith

Date: 2/27/2009

Revision: **NEW**

Stds Committee Approval:  
**APPROVED**

All units shall have cable knockouts located in each corner of the lower portion according to the manufacturer's standard and Chelan PUD's requirements.

**7.3. CABLE PULLING DEVICES**

In addition to the Burke Lifting devices, cable pulling irons shall be mounted in each corner and be suitable as anchors for cable pulling operations. Location in each type unit shall be as shown on specification drawings.





**T&D UG VAULTS & COVERS**  
**PRECAST CONCRETE**  
**- Self Grounding -**

Originator: DSmith

Date: 2/27/2009

Approval: DSmith

Date: 2/27/2009

Page 7 of 7

Revision: **NEW**

Stds Committee Approval:  
**APPROVED**

**8. APPROVED MANUFACTURES**

Utility Vault P.O. Box 588 Auburn, WA 98071	H2 Precast 4919 Contractors Drive East Wenatchee, WA. 98802
Phone: (800) 892-1538 (253) 839-3500	Phone: (509) 884-6644
Fax: (253) 735-4201	
Email: <a href="mailto:uvauburn@oldcastleprecast.com">uvauburn@oldcastleprecast.com</a>	Email: <a href="mailto:cprewitt@h2precast.com">cprewitt@h2precast.com</a>

**9. RELATED STANDARDS & DIMESIONS**

Please refer to the **T&D Material Stock Catalog** for this items detail specifications on the district's web site listed below:

[HTTP://WWW.CHELANPUD.ORG/DISTRICT-STANDARDS.HTML](http://www.chelanpud.org/district-standards.html)

These catalog pages are updated when a change is made to the specifications.

Vendors shall utilize these specifications when responding to a request for quote.

- Material Catalog #1313.01 – 554 Vaults, Concrete, Self Grounding
- Material Catalog #1313.02 – 575 Vaults, Concrete, Self Grounding
- Material Catalog #1313.03 – 612 Vaults, Concrete, Self Grounding
- Material Catalog #1313.04 – 810 Vaults, Concrete, Self Grounding



Originator:

Date: 6/27/2014

Approval: J. Mitchell

Date: 6/27/2014

Page 1 of 3

Revision:

Stds Committee: Approved

**Application:**

- Large single phase (100-167Kva), minipad 75Kva, and 150-300Kva three phase transformer.
- Commercial Secondary Service Box
- Single phase junction vault or splice vault

**Specifications:**

- All covers are 6" thick and H20 rated for light traffic/parking unless otherwise noted.
- All vault bases are self grounding and have grounding inserts accessible internally and externally. All covers have bonding inserts.

Refer to "1313.00 - VAULTS, PRECAST CONCRETE - SELF GROUNDING" for Manufacturing Details

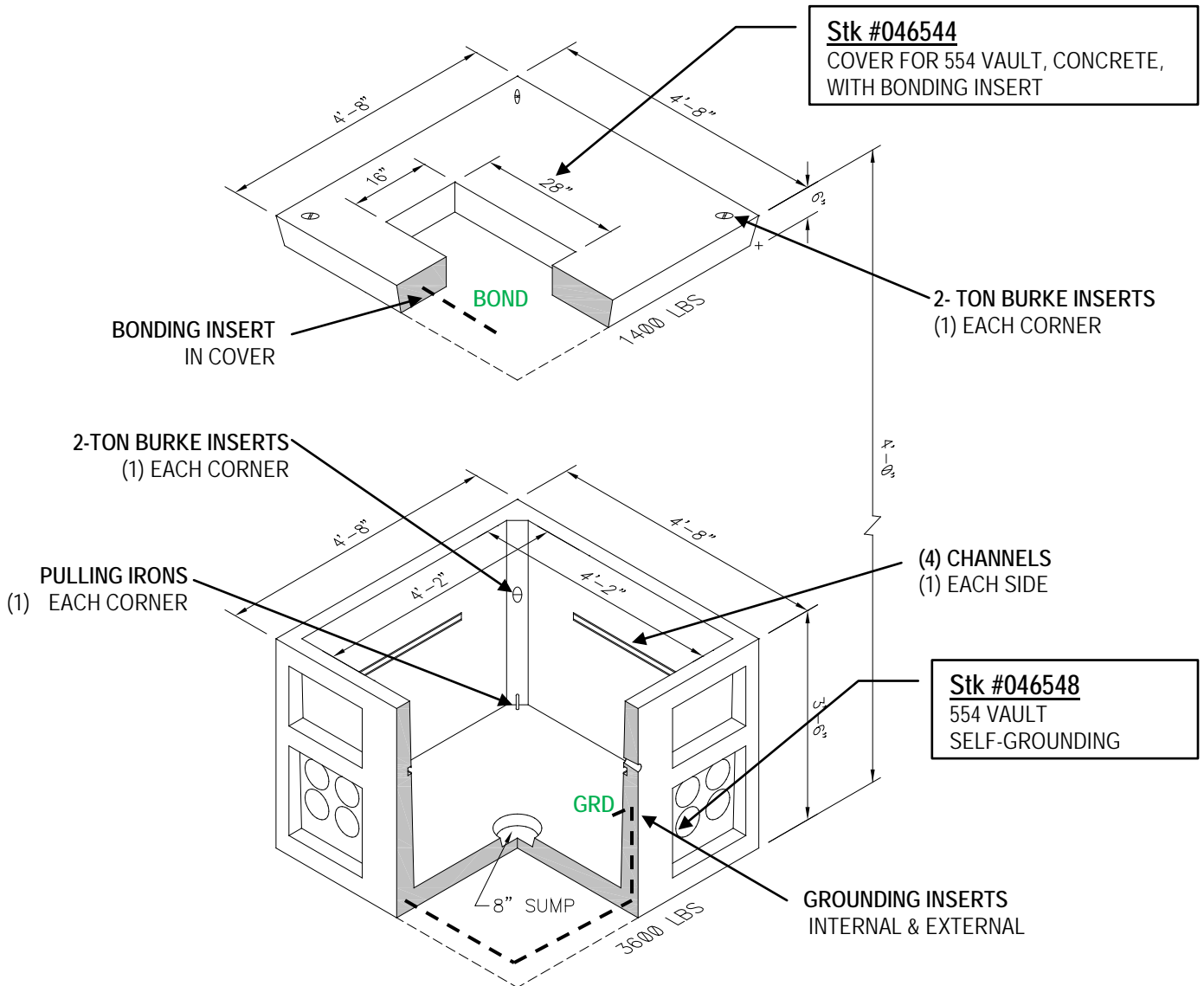



Originator:

Date: 6/23/2009

Approval:

Date: 6/23/2009

Page 2 of 3

Revision: Added 75kav minipad 3ph., increased pad size of 046458 6 inches on both sides.

Stds Committee: Approved

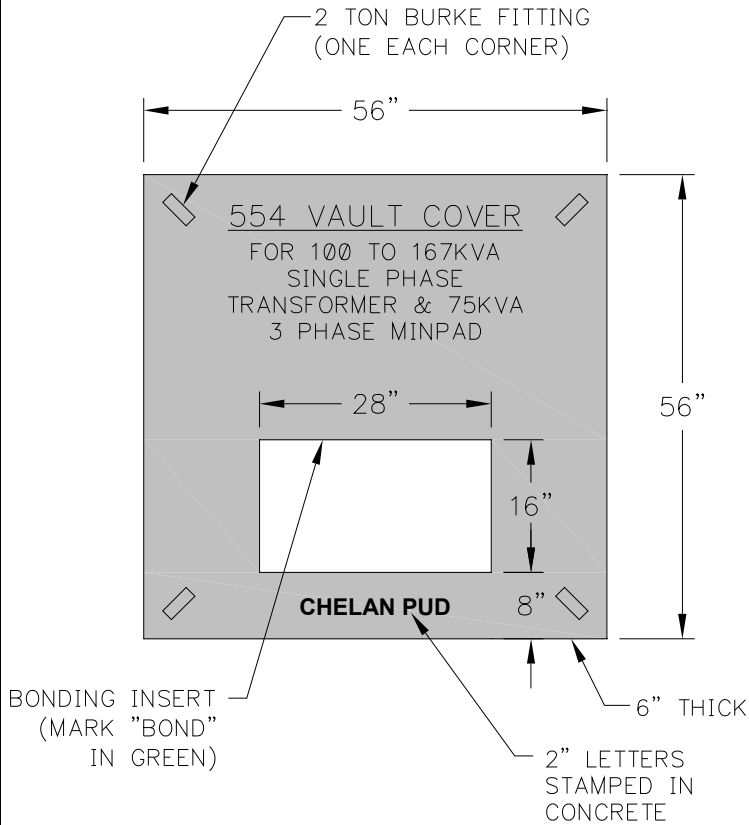

**Stk #046544**  
Cover For 554 Vault, Concrete, with Bonding Insert  
For: 100 To 167kva Single Phase  
AND 75KVA 3-Phase MiniPad Transformers  
1400 lbs

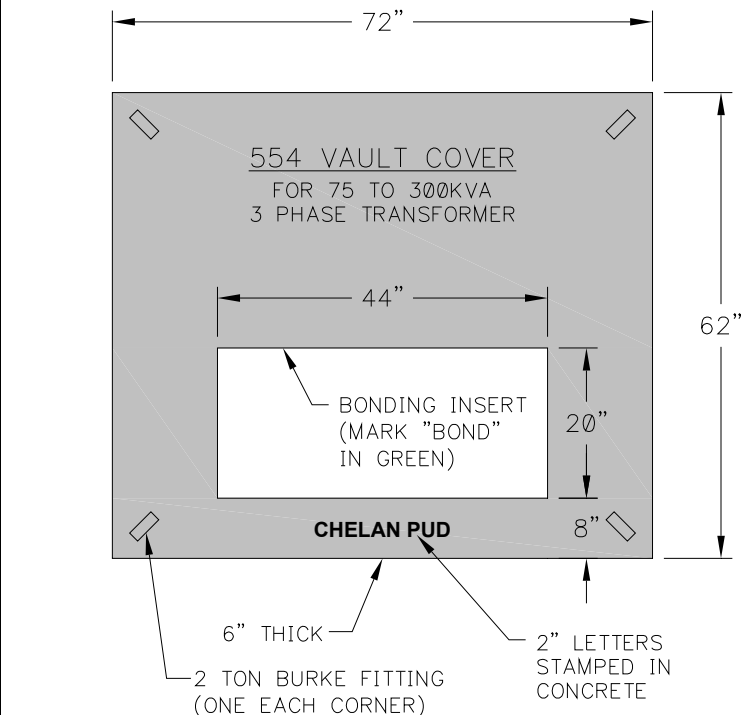

**Stk #046458**  
Cover For 554 Vault, Concrete, with Bonding Insert  
For: 75 To 300kva 3 Phase Transformers  
1550lbs

**Stk #046547 (Not Shown)**  
Cover For 554 Vault, Concrete, with Bonding Insert  
56" x 56" with (1) Spring Assisted Steel Nonslip Door  
1150lbs



Originator: Date: **6/23/2009**

Approval: Date: **6/23/2009**

Revision: Added 75kav minipad 3ph., increased pad size of 046458 6 inches on both sides.

Stds Committee: Approved

**Approved Manufacturers:**

PUD IDENTIFICATION		MANUFACTURER CATALOG NUMBER	
Stock No.	Stock Description	Utility Vault	H2 Precast
046548	VAULT 554 BASE, CONCRETE, 4'8" X 4'8" X 3'6", SELF GROUNDING, H2O LOADING	CC-504-BL	VBCC554
046547	COVER, FOR 554 VAULT, CONCRETE, 56" X 56" X 6", w/ 36"X36" SINGLE SPRING ASSISTED NONSLIP STEEL DOOR W/ BONDING INSERT, 1150 LBS	CC-55-332P	VLCC550-13
046544	COVER, FOR 554 VAULT, CONCRETE, 56" X 56" X 6", w/ BONDING, 100 TO 167KVA 1PH & 75KVA 3PH MINIPAD, 1400LBS	CC-55-1226	TPCC55-1628
046458	COVER, FOR 554 VAULT, CONCRETE, 72" X 62" X 6", w/ BONDING INSERT, 3PH XMR, 75 TO 300KVA,1550LBS	CC-72-2044	TPCC55-2044



**Vaults, Concrete 575**

- Self Grounding -

**Splice/Switch Vault & 3Ph Transformer Base**

**4'8" X 7'-0" x 5'-0"**

Originator:

Date: 6/22/2009

Approval:

Date: 6/23/2009

Page 1 of 2

Revision: Reduced opening size on cover from 24" to 20"

Stds Committee: Approved

**Application:**

- Medium-sized three phase (500, 750Kva) transformers.
- Commercial Secondary Service Box
- Junction vault or splice vault for smaller cables (#2, 4/0)

**Specifications:**

- All vault bases are self grounding and have grounding inserts accessible internally and externally. All covers have bonding inserts

Refer to "1313.00 - VAULTS, PRECAST CONCRETE - SELF GROUNDING" for Manufacturing Details

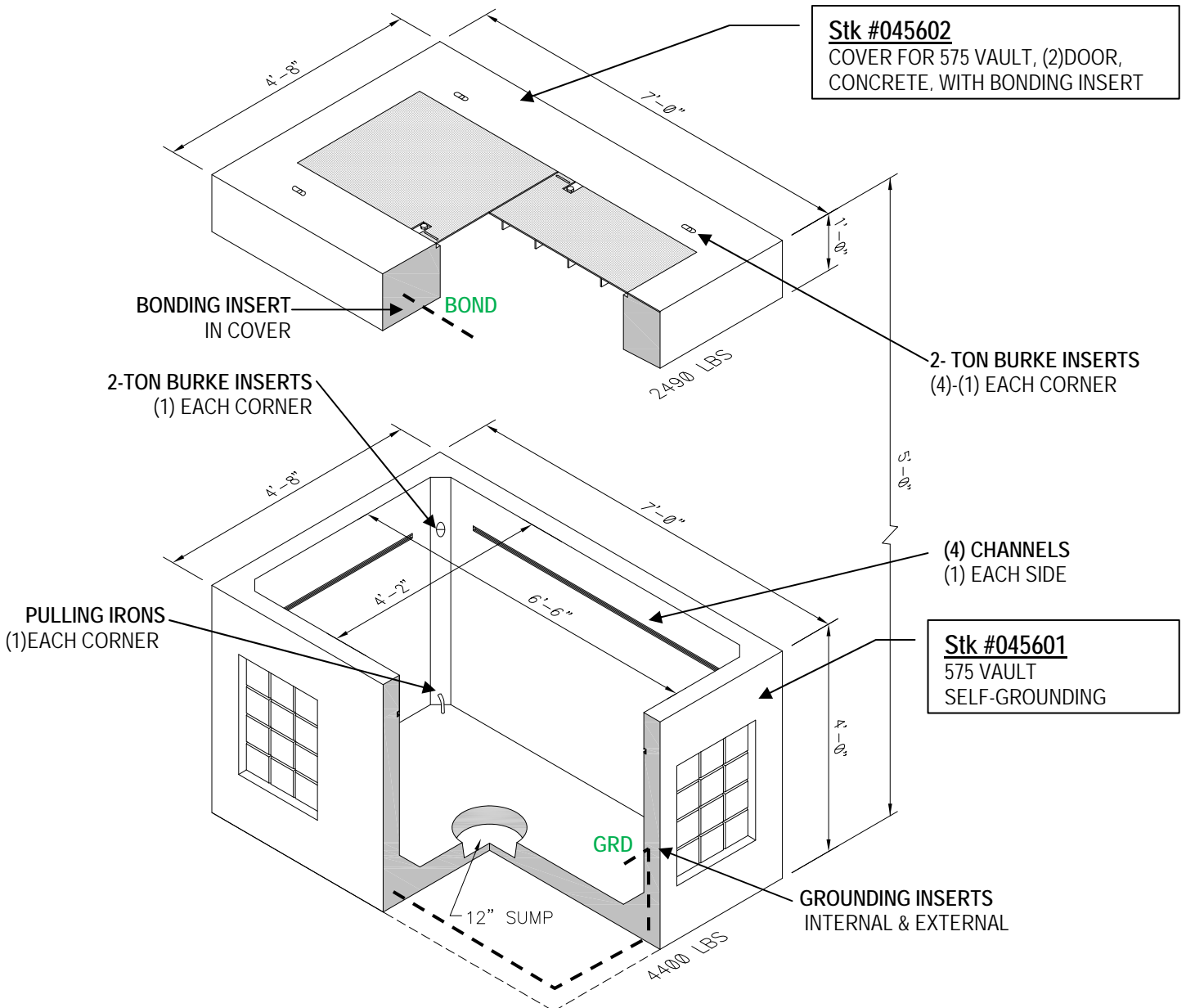



**Vaults, Concrete 575**  
**- Self Grounding -**  
**Splice/Switch Vault & 3Ph Transformer Base**  
**4'8" X 7'-0" x 5'-0"**

Originator:

Date: 6/22/2009

Approval:

Date: 6/23/2009

Page 2 of 2

Revision: Reduced opening size on cover from 24" to 20"

Stds Committee: Approved

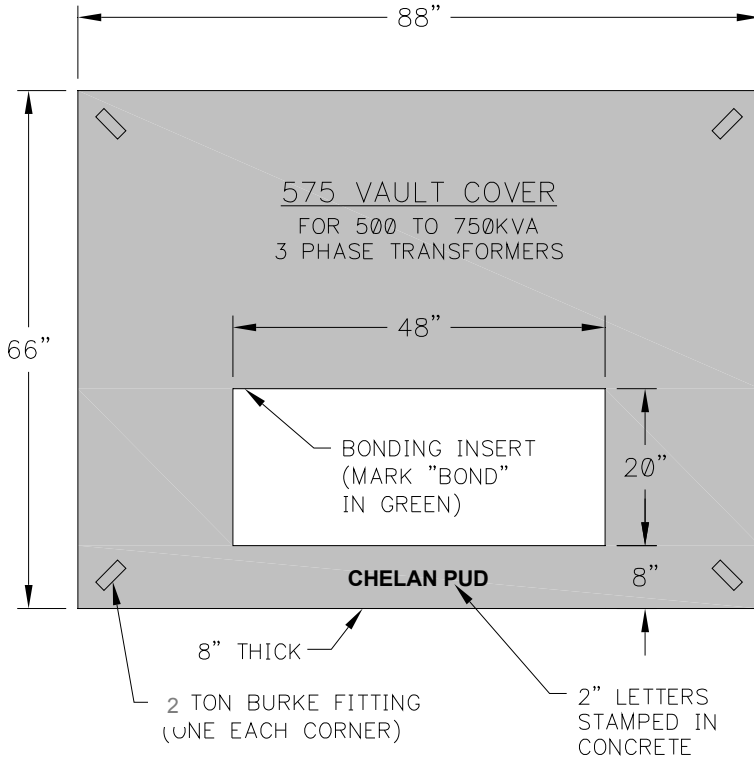

**Stk #045608**

Cover For 575 Vault, Concrete, with Bonding Insert  
For: 500 to 750Kva, 3 Phase Transformers  
2800lbs

**Approved Manufacturers:**

PUD IDENTIFICATION		MANUFACTURER CATALOG NUMBER	
Stock No.	Stock Description	Utility Vault	H2 Precast
045601	Vault, 575 Base, Concrete, Self Grounding, 4400 Lbs	CC-575	VBCC575
045602	Cover, For 575 Vault, Concrete, (2) Spring Assisted Nonskid Steel 3'X3' Doors, with Bonding Insert. 2430 Lbs	CC-575-2-323	VLCC570-23
045608	Cover, For 575 Vault, Concrete, 88" X 66" X 8", with Bonding Insert, 20" x 48" opening - For 3 phase transformers, 500 To 750kva	xxxxx	xxxxxx



# Vaults, Precast Concrete & Covers

## 612 - Self Grounding

6' X 12' X 6' 6" I.D.

Originator: DSMITH

Date: 6/23/2009

Approval: DSMITH

Date: 6/23/2009

Page 1 of 3

Revision: Added UV Catalog #

Stds Committee Approval:  
**Approved**

### Application:

- Three phase splicing or junction vault
- PMH Cabinet (padmounted switchgear) installation
- Primary metering cabinet installations

### Specifications:

- The vault center section is self grounding and has grounding inserts accessible internally and externally. The base and covers have bonding inserts.

Refer to "1313.00 - VAULTS, PRECAST CONCRETE - SELF GROUNDING" for Manufacturing Details

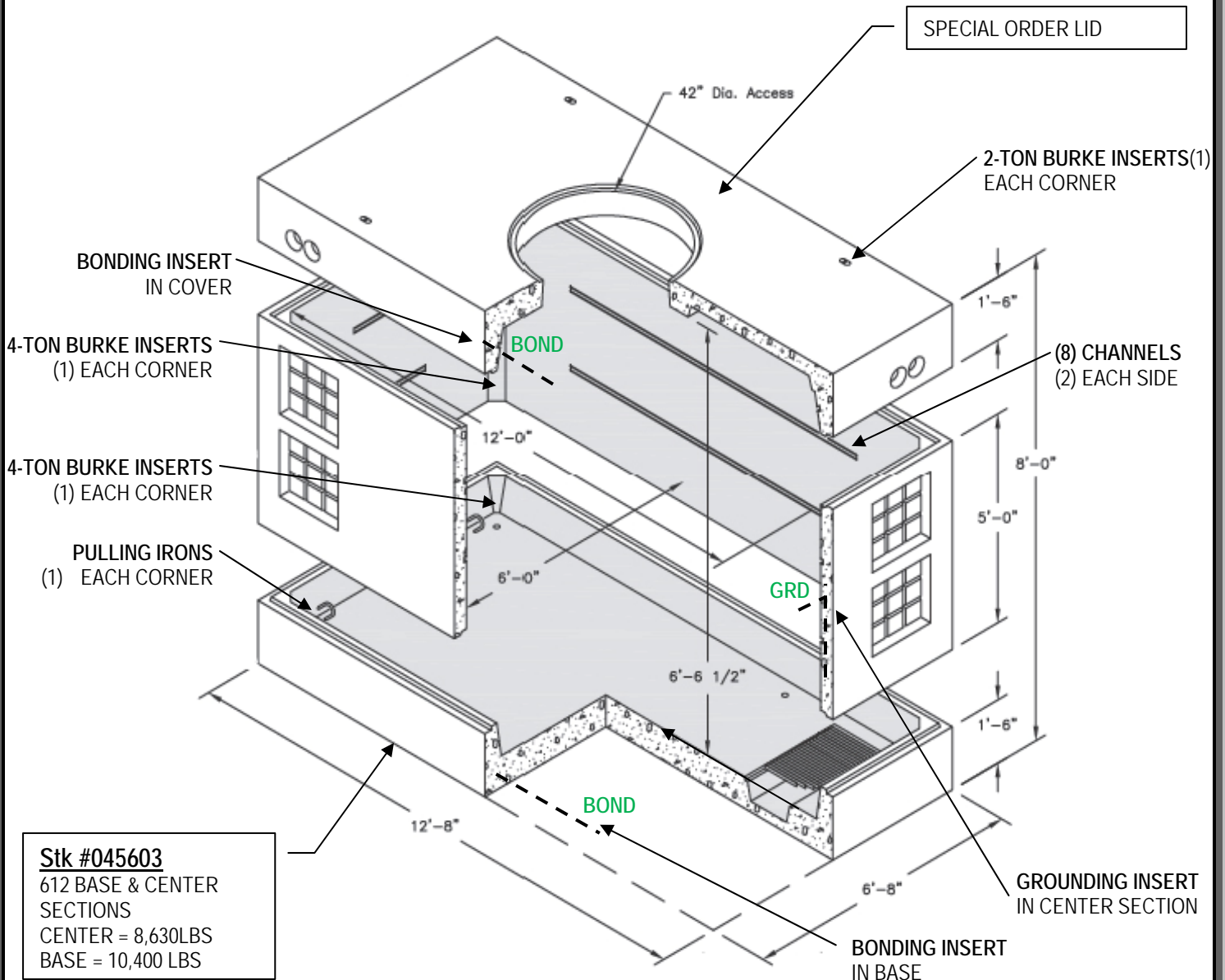

**Stk #045603**  
 612 BASE & CENTER  
 SECTIONS  
 CENTER = 8,630LBS  
 BASE = 10,400 LBS





# Vaults, Precast Concrete & Covers

## 612 - Self Grounding

6' X 12' X 6' 6" I.D.

Originator: DSMITH

Date: 6/23/2009

Approval: DSMITH

Date: 6/23/2009

Page 2 of 3

Revision: Added UV Catalog #

Stds Committee Approval:  
**Approved**

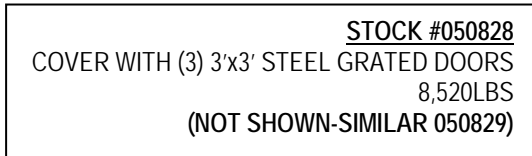
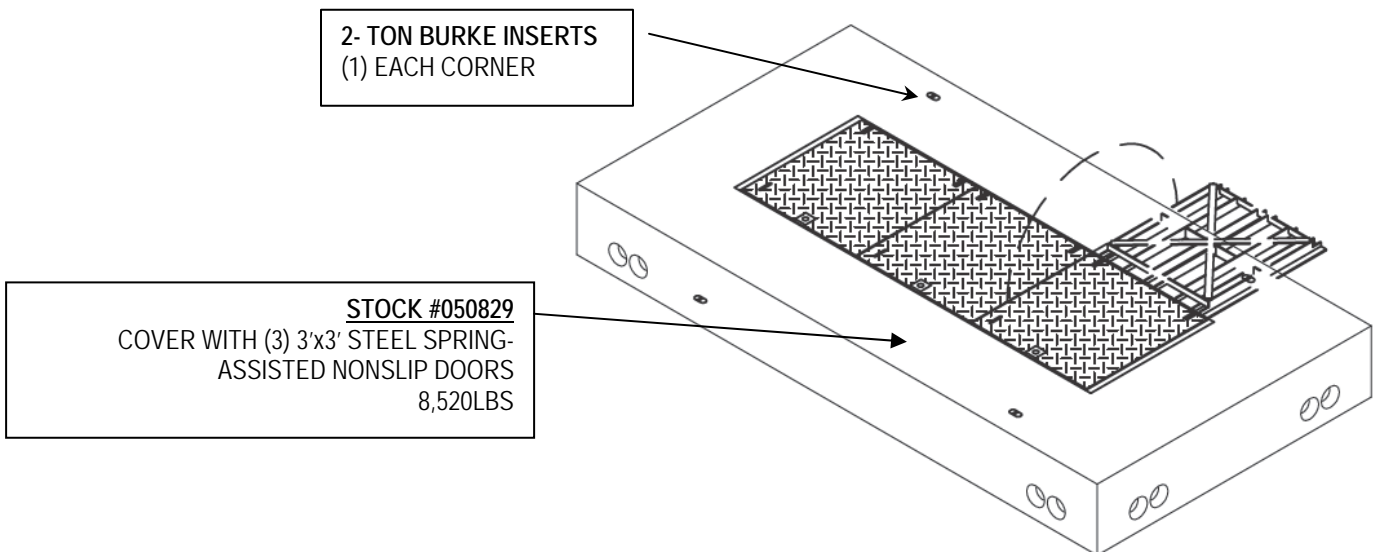
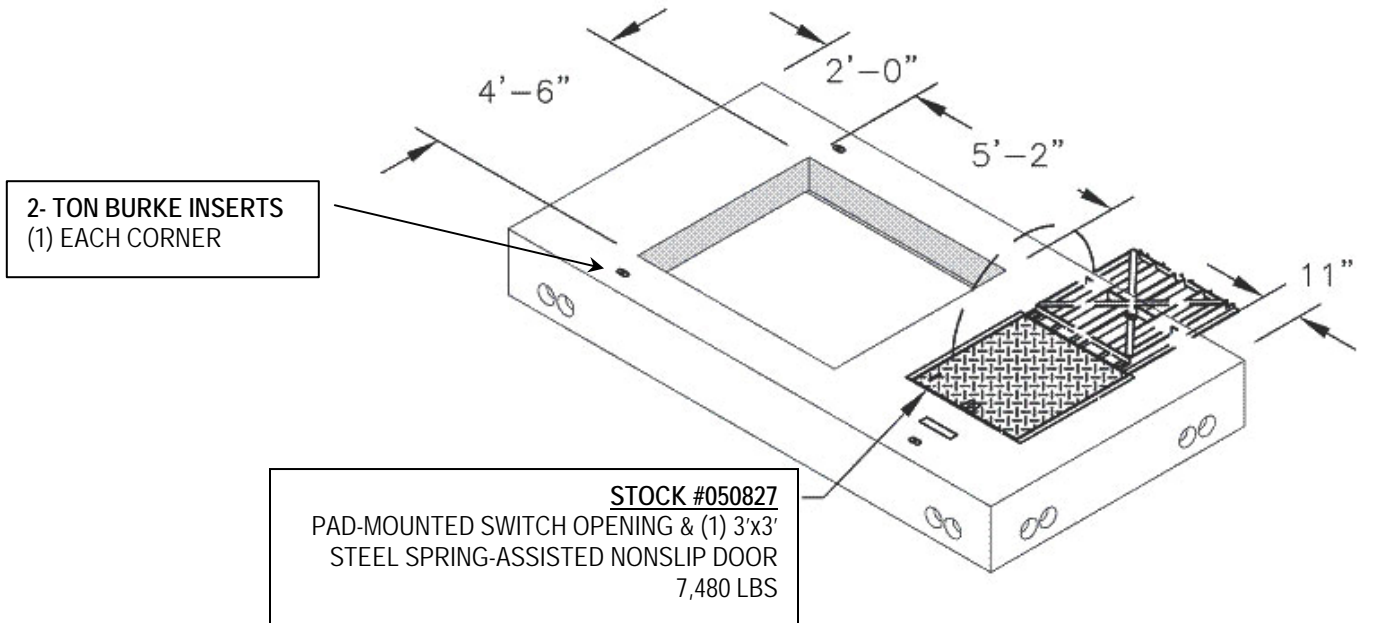



**Vaults, Precast Concrete & Covers**  
**612 - Self Grounding**  
6' X 12' X 6' 6" I.D.

Originator: DSMITH

Date: 6/23/2009

Approval: DSMITH

Date: 6/23/2009

Revision: Added UV Catalog #

Stds Committee Approval:  
**Approved**

**Approved Manufacturers:**

PUD IDENTIFICATION		MANUFACTURER CATALOG NUMBER	
Stk. No.	Stock Description	Utility Vault	H2 Precast
045603	VAULT, 612 BASE & CENTER, CONCRETE, 6' X 12' X 6', SELF GROUNDING, H20 LOADING, TWO PIECES	CC-612BASE & CENTER	VBCC612-B VBCC612-D
050827	COVER, FOR 612 VAULT, CONCRETE, 1 SPRING ASSISTED NONSLIP STEEL DOOR AND 54" X 62" OPENING FOR SW CAB W/ BONDING INSERTS	CC-612 SWITCH TOP	
050829	COVER, FOR 612 VAULT, CONCRETE, 3 SPRING ASSISTED NONSLIP STEEL 3'x3' DOORS W/ BONDING INSERTS	CC-612-3-332P TOP	
050828	COVER, FOR 612 VAULT, CONCRETE, 3 STEEL GRATED LIDS WITH BONDING INSERTS	CC-612-3-332GV TOP	



# Vaults, Precast Concrete & Covers

## 810 - Self Grounding

Originator: DSMITH

Date: 6/23/2009

Approval: DSMITH

Date: 6/23/2009

Revision: NEW

Stds Approval: Approved

### Application:

- Three phase splicing or junction vault
- PMH Cabinet (padmounted switchgear) installation
- Primary metering cabinet installations

### Specifications:

- The vault center section is self grounding and has grounding inserts accessible internally and externally. The base and covers have bonding inserts.

Refer to "1313.00 - VAULTS, PRECAST CONCRETE - SELF GROUNDING" for Manufacturing Details

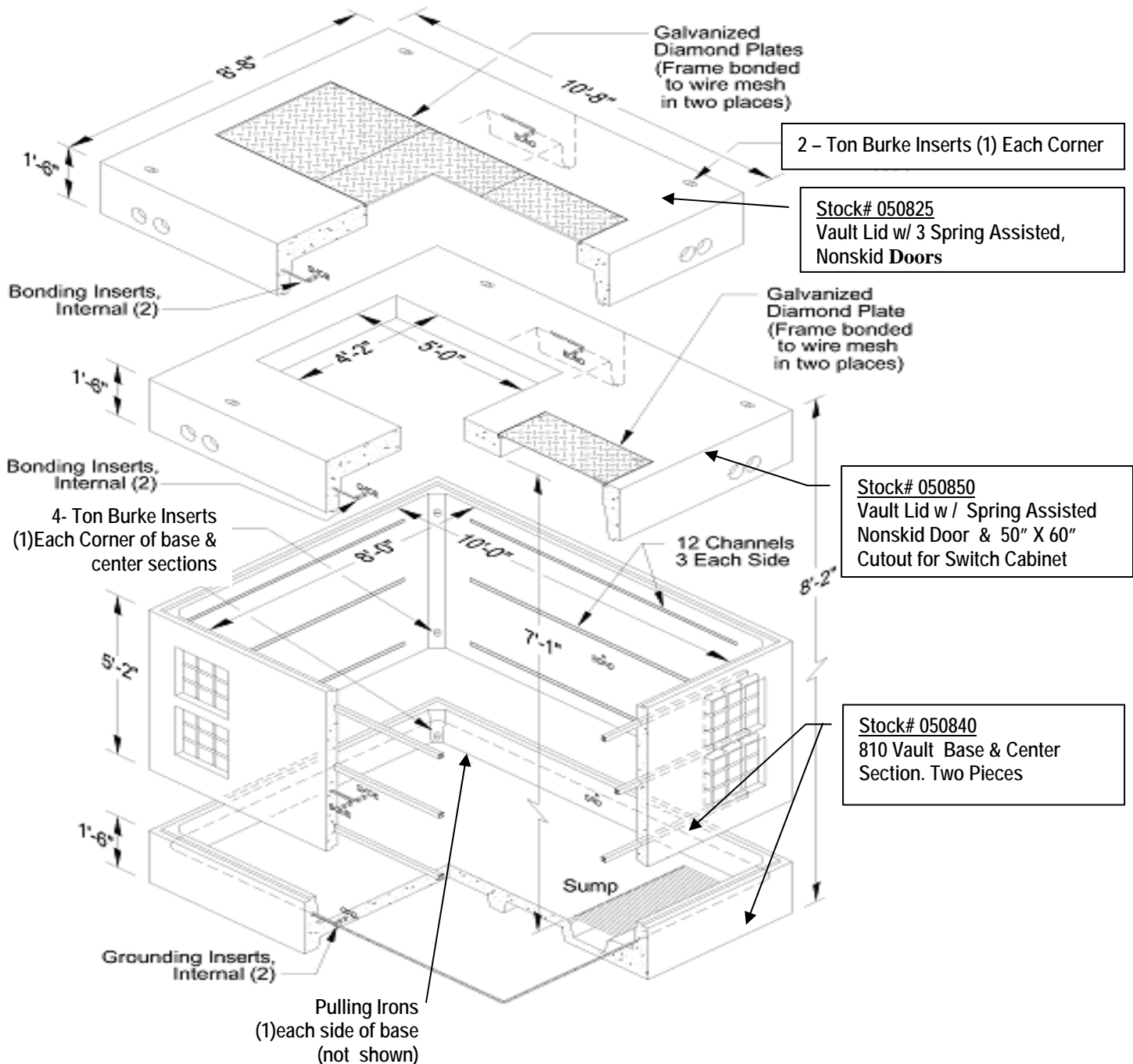



# Vaults, Precast Concrete & Covers

## 810 - Self Grounding

Originator: DSMITH

Date: 6/23/2009

Approval: DSMITH

Date: 6/23/2009

Page 2 of 2

Revision: NEW

Stds Approval: Approved

### Approved Manufacturers:

PUD IDENTIFICATION		MANUFACTURER CATALOG NUMBER	
Item No.	Stock Description	Utility Vault	H2
050825	COVER, FOR 810 VAULT, CONCRETE, 3 SPRING ASSISTED NONSKID STEEL 3'x3' DOORS, W/ BONDING INSERT	CC-810-3-332P TOP	VLCC810-33
050850	COVER, FOR 810 VAULT, CONCRETE, SPRING ASSISTED NONSKID STEEL 3' DOOR AND 50" X 60" SW CAB OPENING W/ BONDING INSERT	CC-810-SWITCH TOP	TPCC810 TRANS LID
050840	VAULT, 810 BASE AND CENTER, CONCRETE, SELF GROUNDING, TWO PIECE.	CC-810- BASE AND CENTER	VBCC810-B VBCC810-D



**Vaults, Precast Concrete & Cover**  
**444 Vault**

Originator: C SLATTA

Date: 6/27/2014

Approval: J. Mitchell

Date: 6/27/2014

Page 1 of 1

Revision:

Stds Approval: Approved

**Application:**

- Commercial Secondary Service Box
- Junction vault or splice vault for single phase, smaller cables (#2, 4/0)

**Specifications:**

- Cover is 6" thick and H20 rated for light traffic/parking unless otherwise noted.

Refer to "1313.00 - VAULTS, PRECAST CONCRETE - SELF GROUNDING" for Manufacturing Details

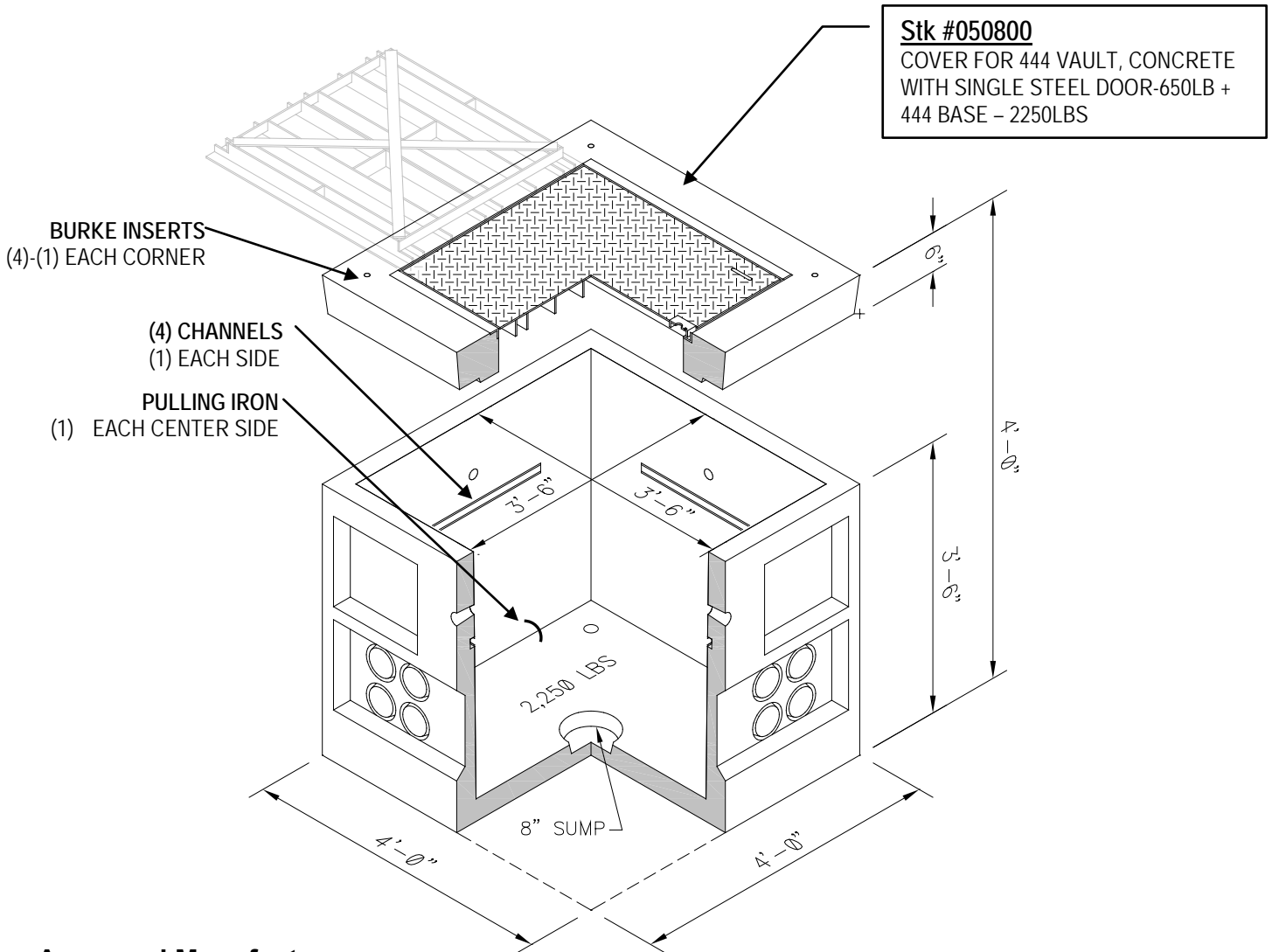

**Approved Manufacturers:**

PUD IDENTIFICATION			MANUFACTURER CATALOG NUMBER	
Item No.	Fig #	Stock Description	Utility Vault	
050800	1	VAULT, 444, BASE AND LID, SPRING ASSISTED NONSKID STEEL 3' DOOR	444-BL and Cover No. 44-332P	



**Vaults, Concrete 774**  
**- Self Grounding -**  
**Large 3-Phase Transformer Base**  
**7'-0" x 7'-0" x 3'-6"**

Originator:

Date: 6/23/2009

Approval:

Date: 6/23/2009

Revision: New vault for Large 3-Phase Transformers

Stds Committee: Approved

**Application:**

- Large three phase transformers 1000-2500kVA
- The vault base is self grounding and has grounding inserts accessible internally and externally. All covers have bonding inserts.

**Specifications:**

- All vault bases are self grounding and have grounding inserts accessible internally and externally. All covers have bonding inserts

Refer to "1313.00 - VAULTS, PRECAST CONCRETE - SELF GROUNDING" for Manufacturing Details

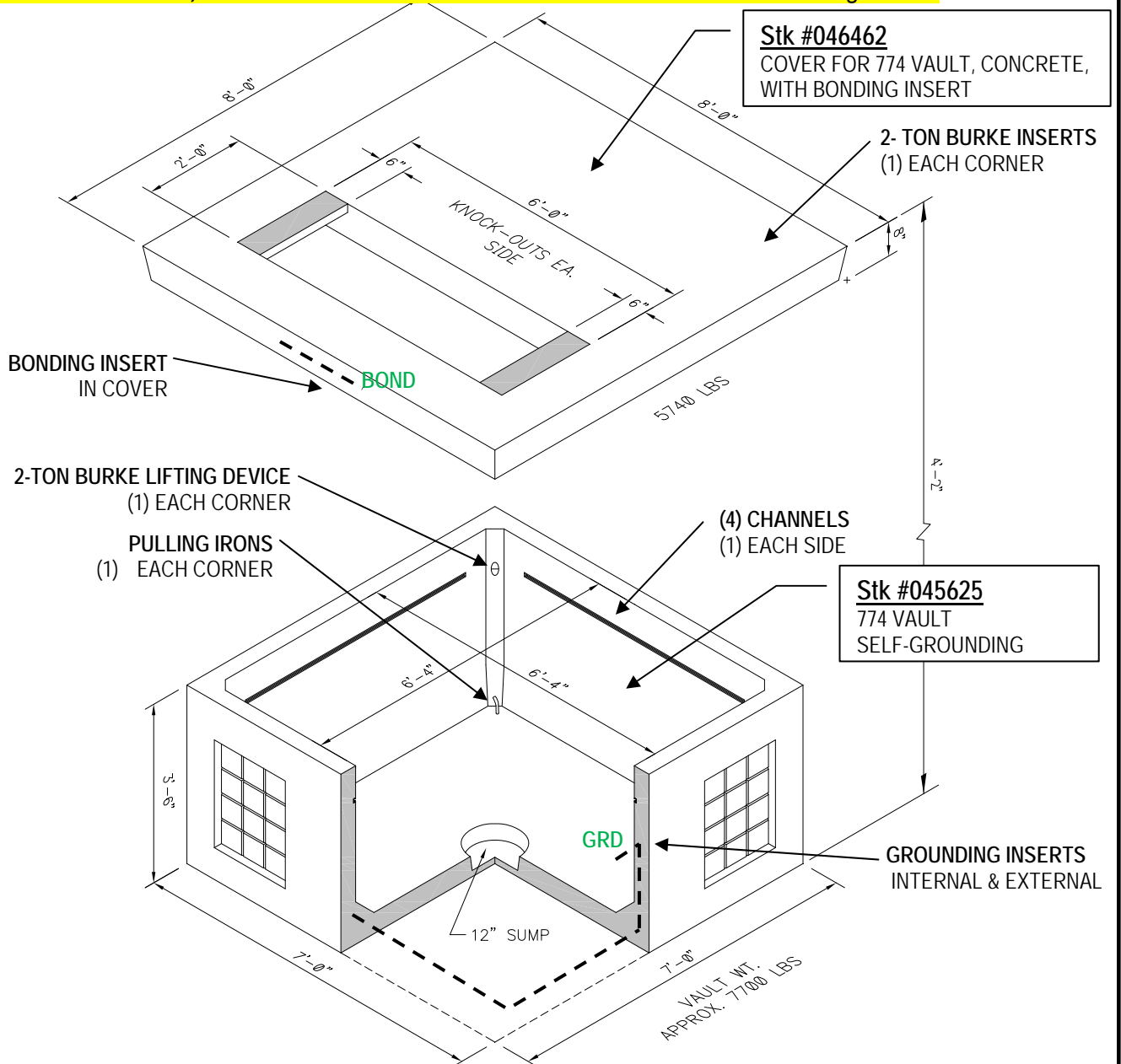



**Vaults, Concrete 774**  
**- Self Grounding -**  
**Large 3-Phase Transformer Base**  
**7'-0" x 7'-0" x 3'-6"**

Originator:

Date: 6/23/2009

Approval:

Date: 6/23/2009

Page 2 of 2

Revision: New vault for Large 3-Phase Transformers

Stds Committee: Approved

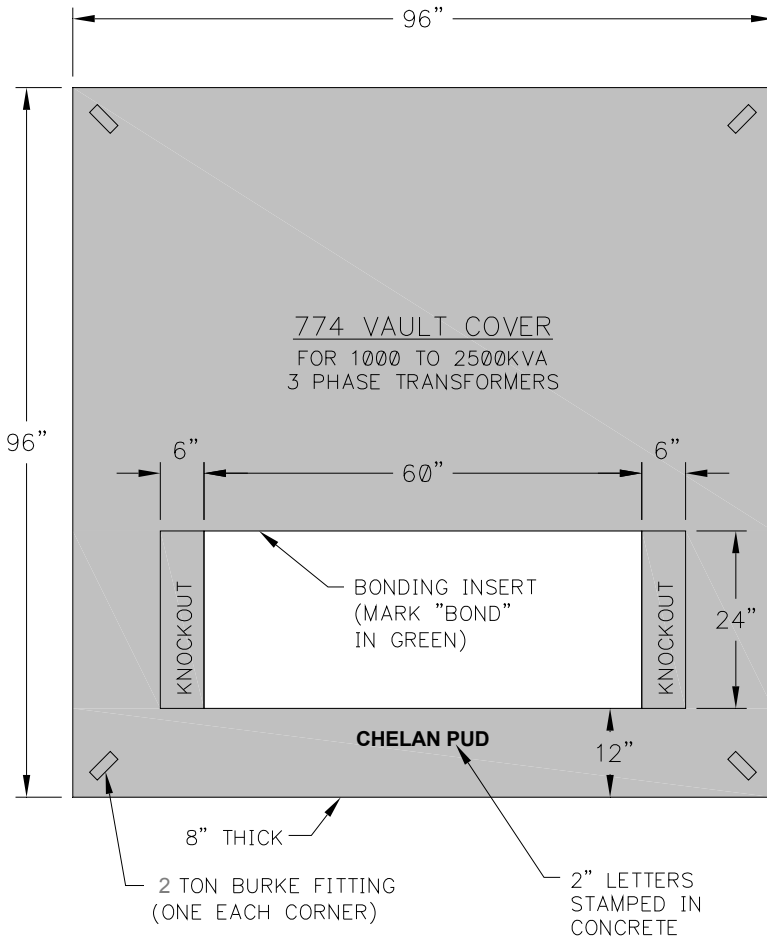

**Stk #046462**  
Cover For 774 Vault, Concrete, with Bonding Insert  
For: 1000 to 2500kVA, 3 Phase Transformers  
5740lbs

PUD IDENTIFICATION		MANUFACTURER CATALOG NUMBER	
Stock No.	Stock Description	Utility Vault	H2 Precast
045625	Vault, 774 Base, Concrete, Self Grounding, 4400 Lbs	XXXX	XXXX
046462	Cover, For 774 Vault, Concrete, 96" X 96" X 8", with Bonding Insert, 24" x 60" opening with (2) - 6" knockouts. For 3PH transformers, 1000 to 2500kva. 5740lbs	CC-88-2460	TPCC88-2460





# Vaults, Precast Concrete & Covers

## 954 - Self Grounding

9'-4" x 5'-4" x 4' O.D.

Originator: C SLATTA

Date: 11/17/2010

Approval: STDS COMM

Date: 11/17/10

Page 1 of 2

Revision: New Vault

Stds Committee Approval:  
**Approved**

**Application:**

- PMH Cabinet (switchgear) installation in limited space areas

**Specifications:**

- Cover is 6" thick and H20 rated for light traffic/parking unless otherwise noted.
- All vault bases are self grounding and have grounding inserts accessible internally and externally. All covers have bonding inserts.

Refer to "1313.00 - VAULTS, PRECAST CONCRETE - SELF GROUNDING" for Manufacturing Details

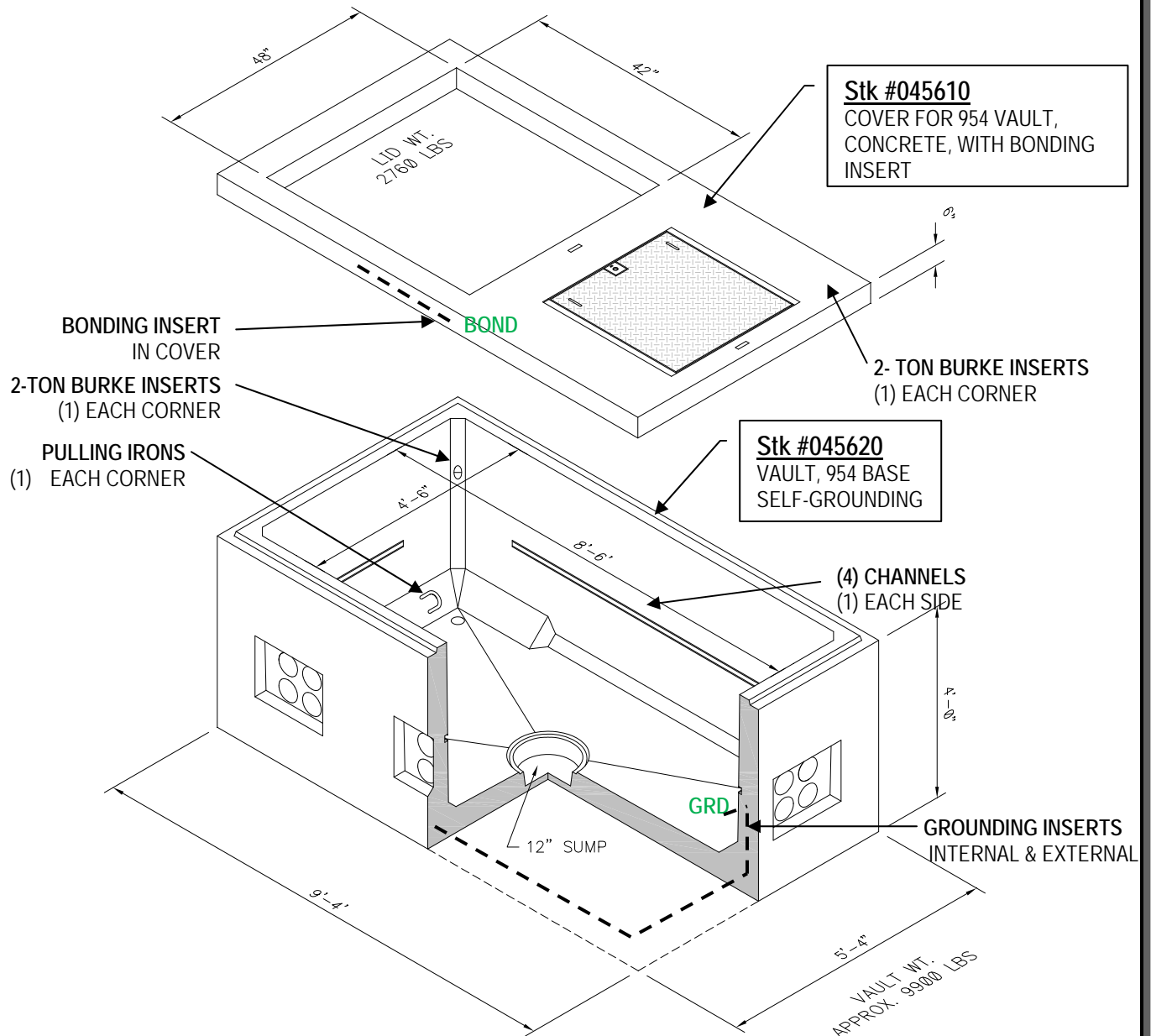

**Approved Manufacturers:**



**Vaults, Precast Concrete & Covers**  
**954 - Self Grounding**  
9'-4" x 5'-4" x 4' O.D.

Originator: C SLATTA

Date: 11/17/2010

Approval: STDS COMM

Date: 11/17/10

Revision: New Vault

Stds Committee Approval:  
**Approved**

**Approved Manufacturers:**

PUD IDENTIFICATION			MANUFACTURER CATALOG NUMBER	
Figure	Stock No.	Stock Description	Utility Vault	H2 Precast
1	045610	COVER, FOR PMH CABINET WITH 42" X 48" OPENING AND 36" X 36" SPRING ASSISTED STEEL DOOR		
2	045620	VAULT, 954 BASE, CONCRETE, 9'-4" x 5'-4" x 4', SELF GROUNDING. SPECIAL COVER: WITH 42" x 48" OPENING AND 36" X36" SPRING ASSISTED, NON-SKID STEEL DOOR	XXXX	



**SECTIONALIZING CABINET, 15kv, 200AMP  
Single & Three Phase  
with Mounting Hardware.**

Originator: DSmith

Date: 08/31/2006

Approval: J. Mitchell

Date: 05/26/2011

Page 1 of 1

Revision: Changed Approved Manufacturers and Photos

Stds Committee Approval: **Approved**



**Specification:** Terminating cabinets shall meet the requirements of Western Underground Committee Guide 2.13 and shall be constructed of all-welded construction 12 gauge steel. The lid shall be hinged at the top and secured with a stainless steel Penta-head bolt and have provisions for a padlock. A "Wind Stop" shall be included to prevent the top-hinge from closing inadvertently. The enclosure shall be painted with Munsell Green (7GY 329/1.5). All hardware and hinges shall be 304 stainless steel.

Each unit shall include one or more 4-position 15kv 200 amp load break cable junction modules (Elastimold, Hubbell or Cooper) Two parking stands shall be located inline with each junction module, (one on each side of the cable junctions).

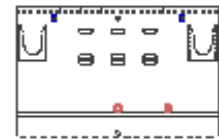

Three grounding lug provisions shall be mounted on the inside back cabinet wall in a horizontal alignment. All cable junction mounting plates and parking stands shall have one ground lug provision each and be painted white or light gray. All grounding provisions shall come equipped with Fargo #GC-207 or Erico #CC207 grounding lugs.

In addition, **four (4) sets of 1-1/4" X 3/8" stainless steel mounting bolts, lock washers, and nuts** shall be provided in a bag attached to each unit to facilitate attachment to a fiberglass ground sleeve.

**Packaging and Marking:** Items shall be suitably packaged to prevent damage. The container shall be convenient for handling and storage. Manufacturer's name or symbol and catalog number shall be on each part and/or its packaging.

**Table 1: Minimum Dimensions:**

Description	Material Gauge	Quantity of Modules	Dimensions D X W X H (inches)	Base Opening D X W (inches)	Weight (lbs)
Cabinet, Term., 1 Phase	12	1	18 x 30 x 30	13 X 26	95
Cabinet, Term., 3 Phase	12	3	24 X 67 X 30	19 X 63	225

**Table 2: Approved Manufacturers:**

PUD IDENTIFICATION		MANUFACTURER CATALOG NUMBER
Stock Description	Stock#	Hoffman or Approved Equal
Cabinet, Sectionalizing, 1 Phase, 15Kv 200A, w/ Mtg Hardware	041765	UJ303018M2
Cabinet, Sectionalizing, 3 Phase, 15Kv 200A, w/ Mtg Hardware	041791	UJ306724M2



**SLEEVE, GROUND, FIBERGLASS  
 FOR 15KV TERMINATING CABINETS**

Originator: DSmith

Date: 06/17/2009

Approval: J Mitchell

Date: 05/26/2011

Page 1 of 1

Revision:

Stds Committee Approval: **Approved**

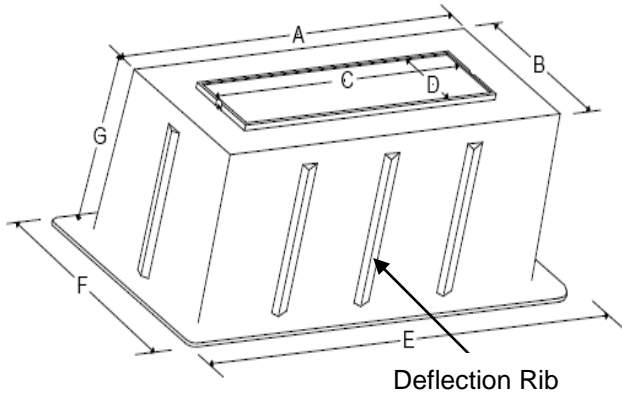

**Application:** Used to supply a base for single phase & three phase 15kV 200Amp terminating cabinets.

**Specification:** Each unit shall be produced in a female mold of fire retardant layers of 16 oz woven roving reinforcement cloth with a C-type or E-Type fiberglass and resin mix. The exterior finish shall be covered with a smooth Munsell Green gel-coat, which contains UV stabilizer for superior weatherability. The units shall be non-conductive and have external deflection ribs for increased deflection resistance. Deflection ribs shall be placed at a minimum: (1) every 24”.

**Exact Dimensions:**

	Top (inches)		Opening (inches)		Base (inches)		Height (inches)
	A	B	C	D	E	F	
1 Phase	33	24	26	12	45	36	30
3 Phase	69	26	60	18	88	42	30

**Packaging and Marking:** Items shall be suitably packaged to prevent damage. The container shall be convenient for handling and storage. Manufacturer’s name or symbol and catalog number shall be on each part or (and) its packaging.

**Approved Manufacturers:**

PUD IDENTIFICATION		MANUFACTURER CATALOG NUMBER
Stock Description	Stock No.	Proglass
Sleeve, Ground, Fiberglass, for 1 Phase Term, Cabinet	041670	S332430
Sleeve, Ground, Fiberglass, for 3 Phase Term, Cabinet	041671	S692630



**Pad Mounted 600V Termination Cabinet**

Originator: **DSmith**

Date: **6/10/2011**

Approval: **J Mitchell**

Date: **06/10/2011**

Page **1** of **2**

Revision: Change # connections from 20 to 22 for small cabinet. Added Minimum Dimensions. Revised approved manufacturers section.

STD Committee: **Approved**

- 1. Application:** This equipment is intended for use as a secondary junction point between a District's large three phase padmount transformer and Customer owned switchgear where the number of customer secondary cables exceeds 12 per phase.
- 2. Reference Standards:** Except as modified herein, these enclosures shall meet the applicable requirements of the latest revisions of ANSI C57.12.28 and ANSI C119.4.

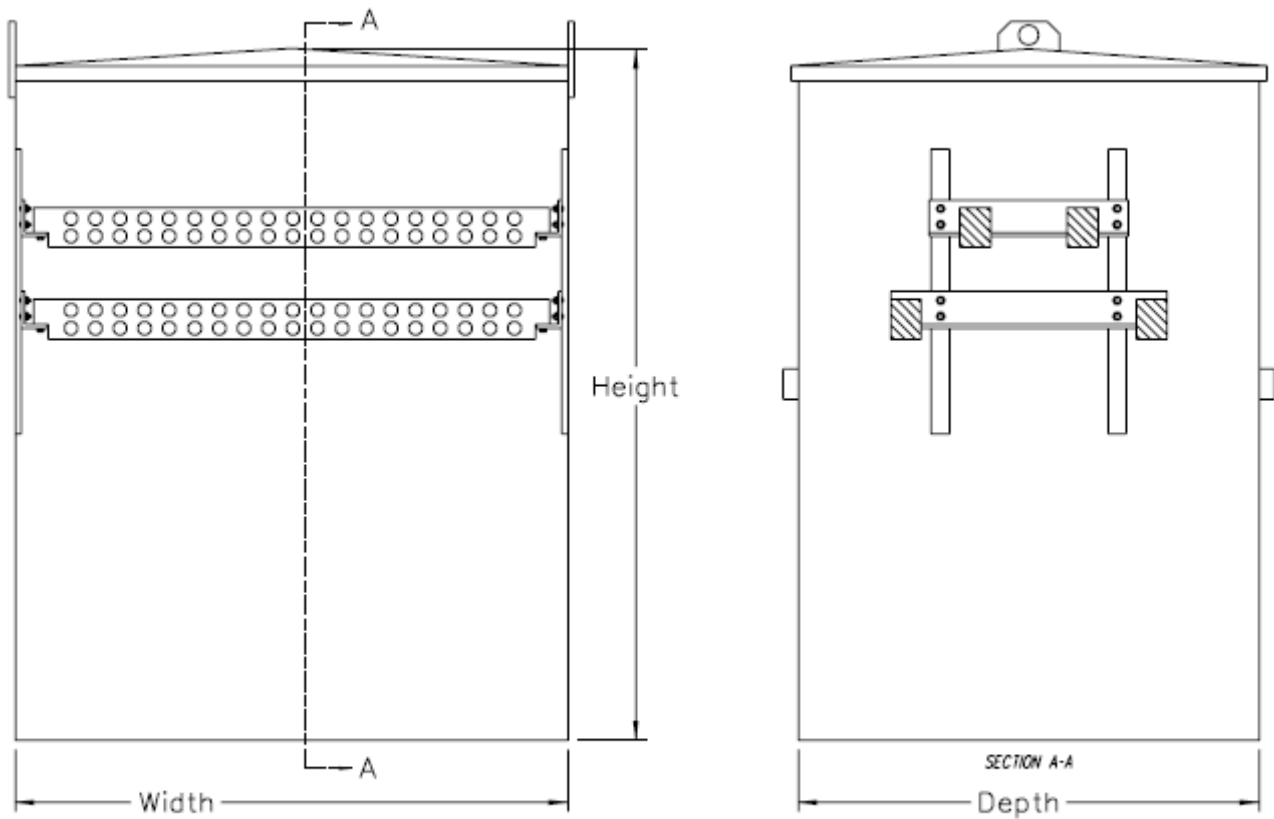

Figure 1

Minor variations in enclosure dimensions may be allowed with prior District Approval.

**3. Approved Manufacturers:**

Stock No.	PUD IDENTIFICATION Stock Description	Dimensions			
		CMC	Hoffman	Duram	Shallbetter
041766	<b>600V Termination Enclosure, Pad Mounted, Small Cabinet</b>	LTPE22-750C			
041767	<b>600V Termination Enclosure, Pad Mounted Large Cabinet</b>	LPTE30-750SC			



## Pad Mounted 600V Termination Cabinet

Originator: **DSmith**

Date: **6/10/2011**

Approval: **J Mitchell**

Date: **06/10/2011**

Page 2 of 2

Revision: Change # connections from 20 to 22 for small cabinet. Added Minimum Dimensions. Revised approved manufacturers section.

STD Committee: **Approved**

#### 4. Minimum Dimensions:

Description	Material Gauge	No. of Conductors per phase	Dimensions D X W X H (inches)	Minimum Bus Rating	Approximate Weight (lbs)
Small Cabinet	12	24	30" x 36" x 44"	4000	95
Large Cabinet	12	30	54" X 48" X 44"	4000	225

#### 5. Specification:

##### 5.1. Cabinet:

The cabinet shall be manufactured from galvanized steel, stainless steel or 5052-H32 aluminum. Cabinet thickness shall be 12 gauge minimum for steel and 0.125 inch minimum for aluminum. The cabinet and supporting frame shall be sufficiently strong to prevent noticeable deflection or distortion to the cabinet during installation and use. The cabinet roof shall be crowned so as to shed water. The cabinet shall include lifting provisions.

##### 5.2. Doors

Each termination enclosure shall be equipped with side-hinged doors designed to swing open horizontally. The doors shall be located on opposite sides of the cabinet and parallel to the bus bars. Doors shall be of sufficient size to allow full access to the bus bars and cabinet interior and be equipped for latching in the open position.

##### 5.3. Finish

The enclosure finish shall meet or exceed the requirements of ANSI C57.12.28, latest revision. The topcoat color of paint shall be dark green Munsell No. 7GY 3.29/1.5. Combined primer and topcoat thickness shall be no less than 3.0 mils. Primer and paint shall be lead free.

##### 5.4. Set Screw Bus Bars

Each enclosure shall be equipped with four set screw bus bars (one per phase). These bars shall be manufactured from 6061-T6 aluminum or a District approved equivalent and shall be fully tested per ANSI C119.4 for Class A connectors. Bus bars shall have a minimum 4,000 amp load rating.

Set screw bus bars shall utilize two 3/8 inch allen head set screws per cable position and shall accommodate cable sizes from #2 through 750 kcm. Holes shall actually be drilled to fit 800 kcm cables. Set screw bus bars shall be compatible with aluminum or copper conductors.

Set screw bus bars shall be installed in the cabinet on a nonconductive mounting bracket. All mounting hardware shall be stainless steel. Bus bar locations shall be staggered as shown in Figure 1. The bus bars, mounting bracket and hardware must be of sufficient strength to support full secondary cable weight without the need for supplemental cable supports.

Each bus bar shall be equipped with an insulated 105°C rated plastic cover of District approved design.

#### 6. Packaging and Marking: Pad-mounted secondary termination enclosures shall be shipped in an enclosed van and secured to individual nonreturnable wooden pallets suitable for handling with a forklift.



# Fuses & Arrestors

Originator: DSmith

Date: 7/9/2007

Approval: DSmith

Date: 7/9/2007

Page 1 of 1

Revision: **NEW**

Stds Committee Approval:  
**Approved**

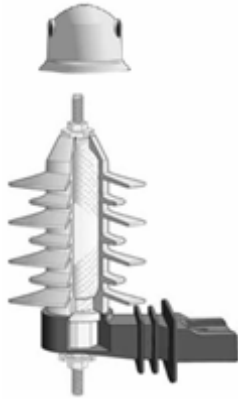

# FUSES & ARRESTERS







**SURGE ARRESTERS, METAL OXIDE  
DISTRIBUTION CLASS**

Originator: DSmith

Date: 7/25/2006

Approval: DSmith

Date: 6/28/2007

Page 1 of 1

Revision: **NEW**

Stds Committee Approval:  
**Approved**



**Application:** This standard applies to metal-oxide surge arresters designed to limit the voltage surges on 60 Hz power circuits by passing surge discharge current to ground and automatically limiting the flow of system power current.

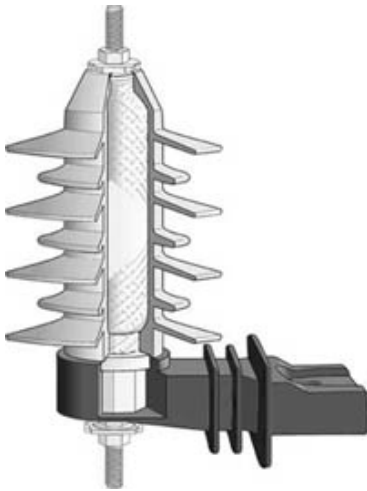

**Applicable Standards:** IEEE Standard for Metal-Oxide Surge Arresters for Alternating Current Power Circuits, C62.11

**Specification:** Metal Oxide Varistor with Polymer S. With ground lead isolator, insulating base bracket, protective terminal cap, Silicon Bronze Nut, Stainless Steel Wire Clamp with Wildlife Protector and without crossarm mounting bracket.

**Packaging and Marking:** Items shall be suitably packaged to prevent damage. The container shall be convenient for handling and storage. Manufacturer's name or symbol and catalog number shall be on each part or (and) its packaging.

**Commonly Applied Arrester Voltage Ratings:**

System Voltage		Recommended Arrester Rating per IEEE C62.22 (kV rms)			
Nominal	Maximum	MCOV	4-Wire WYE Multi Grounded Neutral	3-Wire WYE Solidly Grounded Neutral	Delta and Ungrounded WYE
12.47Y/7.2	13.2Y/7.62	7.65	9	12	-
13.8	14.52	15.3	-	-	18

**Approved Manufacturers:**

PUD IDENTIFICATION		MANUFACTURER CATALOG NUMBER		
Stock Description	Stock No.	Hubbell	Joslyn	Cooper
Arrester, Lightning, 9kV MOV, Heavy Duty with Isolator and Wildlife Protector. 7.65 MCOV	006750	213708-7314	ZHP009-0000100	UHS0905-0A1A-1A1A
Arrester, Lightning, 9kV MOV, Riser Pole with Isolator and Wildlife Protector. 7.65 MCOV	006770	221608-7314	ZRP009-0000100	URS0905-0A1A-1A1A
Arrester, Lightning, 18kV MOV, Heavy Duty with Isolator and Wildlife Protector. 15.3 MCOV	006780	213715-7314	ZHP018-0000100	UHG1808-0A1A-1A1A



**ARRESTERS, STATION CLASS METAL OXIDE**

Originator: DSmith

Date: 7/25/2006

Approval: DSmith

Date: 6/28/2007

Page 1 of 1

Revision: **NEW**

Stds Committee Approval:

**Approved**



**Application:** Used to protect substations from lighting and switching voltage surges.

**Packaging and Marking:** Items shall be suitably packaged to prevent damage. The container shall be convenient for handling and storage. Manufacturer's name or symbol and catalog number shall be on each part or (and) its packaging.

**Shipping:** No Special Shipping Instructions

**Approved Manufacturers:**

PUD IDENTIFICATION		MANUFACTURER CATALOG NUMBER		
Stock Description	Stock No.	Cooper	Westinghouse	Hubbell
Arrester, Lightning, 9kv, Sub Intermediate Class	006730		8046A10A09	
Arrester, Lightning, 19kv, Utrasil Veri Gap HD MOV	006780	UHG18080A1A1B1A		
Arrester, Surge Substation	007150			VL-219508-3001



**CLAMP, LIGHTNING ARRESTER**

Originator: DSmith

Date: 7/7/06

Approval: J Mitchell

Date: 8/10/11

Page 1 of 1

Revision: Misc.

Stds Committee Approval: **Approved**

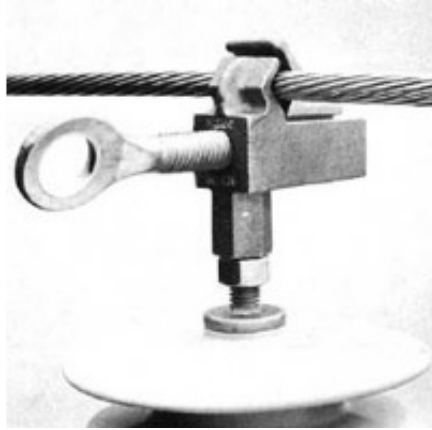

**Application:** Used to attach Lightning Arrester to Conductor. Operable with a hotstick.

**Specification:** Units shall be made from utility grade bronze.

**Packaging and Marking:** Items shall be suitably packaged to prevent damage. The container shall be convenient for handling and storage. Manufacturer's name or symbol and catalog number shall be on each part or (and) its packaging.

**Approved Manufacturers:**

PUD IDENTIFICATION		MANUFACTURER CATALOG NUMBER
Stock Description	Stock No.	Hubbel
CLAMP, LIGHTNING ARRESTER, CONNECTOR, #6-#10	014200	GO-375



**Open-Type Cutouts 15kV,  
100/200 Amp 10,000 Amp Interrupting  
Polymer Insulator**

Originator: DSmith

Date: 7/7/06

Approval: J. Mitchell

Date: 8/16/2013

Page 1 of 1

Revision: Revised S & C Cutout catalog numbers.

Stds Committee Approval:  
**Approved**



**Application:** This device is used to provide overcurrent protection and visible indication of fuse operation for the overhead 15kV distribution system. The cutout can also provide a visible break sectionalizing point for maintenance personnel, and can function as a loadbreak switch when used in conjunction with a portable loadbreak tool.

**Insulator:** Insulator shall be made of composite-polymer silicone.

**Loadbuster Hooks:** All cutouts shall have loadbuster hooks for use with S&C loadbuster tool.

**Brackets:** Cutouts shall have standard NEMA Class B bracket, galvanized steel.

**Ratings:**

- Class I: 100 amps, 15kV max., 110kV BIL, Interrupting rating: 10,000 amps AIC. @60Hz
- Class II: 200 amps, 15kV max., 110kV BIL, Interrupting rating: 12,000 amps AIC. @60Hz

**Fuseholder:** The fuseholder tube shall be an S&C TYPE XS fiberglass or fully compatible equivalent.

**Connectors:** Conductor connectors shall be standard parallel-groove type for wire size #6 Sol. to 2/0 Str. Cu. or Al.

**Packaging and Marking:** Items shall be suitably packaged to prevent damage. The container shall be convenient for handling and storage. Manufacturer's name or symbol and catalog number shall be on each part and its packaging.

**Approved Manufacturers:**

PUD IDENTIFICATION		MANUFACTURER CATALOG NUMBER		
Stock Description	Stock No.	ABB	S&C	Cooper
CUTOUT, 15kV 100A, Polymer	016000	X1JCBNAM11	SC15HG110-CD	S4B1P1A
CUTOUT, 15kV 200A, Polymer	016080	X2JCBNBA22	SC15HD212-CD	S4B2P1A
FUSEHOLDER only, 15kV, 100A	017200	7194C60G01MP	89521R10	LDB100A
FUSEHOLDER only, 15kV, 200A	017210	7194C60G19	89571R11	LDB200A
SOLID BLADE for 100A Cutout	017100	7194C60G04	89621R10	LDB300A
SOLID BLADE for 200A Cutout	017110	None	89622R10	LDB300A

**Salvage Instructions:** Items removed from service in good condition shall be salvaged for reuse.



**FUSE HOLDER, POWER FUSE**

Originator: DSmith

Date: 7/25/2006

Approval: DSmith

Date: 7/9/2007

Page 1 of 1

Revision: **NEW**

Stds Committee Approval:  
**Approved**

SM-4Z

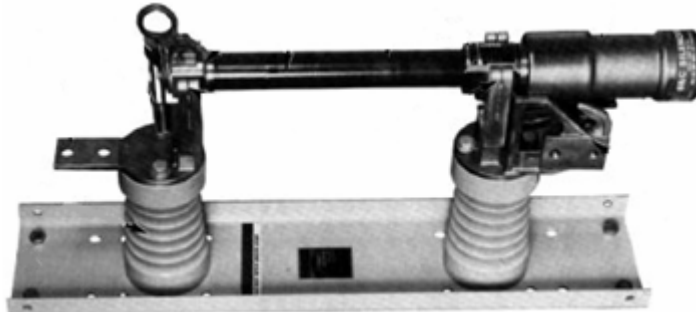
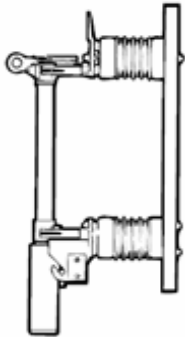

SML-4Z

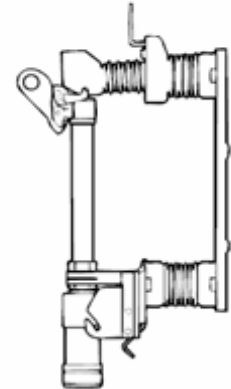

**Application:** These fuses are utilized in indoor and outdoor metal enclosures on 15kv systems. They consist of a fuse unit and fuse holder. The bases and insulators are not part of this assembly.

**Specification:**

1. The SM-4Z fuse is a non load break fuse assembly rated up to 200 Amps.
2. The SML-4Z fuse assembly contains a Uni-Rupter and is designed for single-pole live-switching duties in single-phase or three-phase circuits of distribution systems rated 14.4 kV. The unit shall be designed for a one-time fault closing equal to the interrupting rating of 20,000 amperes RMS asymmetrical at 14.4 kV and a two-time capability of 13,000 amperes RMS asymmetrical at 14.4 kV. The maximum fuse size is 200 Amps.

**Packaging and Marking:** Items shall be suitably packaged to prevent damage. The container shall be convenient for handling and storage. Manufacturer's name or symbol and catalog number shall be on each part or (and) its packaging.

**Shipping:** No Special Shipping Instructions

**Approved Manufacturers:**

PUD IDENTIFICATION		MANUFACTURER CATALOG NUMBER
Stock Description	Stock No.	S & C
FUSE HOLDER, SM-4Z, 15KV W/ SILENCER, NON LOAD BREAK.	166477	86632R2
FUSE HOLDER, SML-4Z, 15KV W/ SILENCER, LOAD BREAK	166479	92352



**FUSE HOLDER, BAY-O-NET**

Originator: DSmith

Date: 7/25/2006

Approval: DSmith

Date: 6/29/2007

Page 1 of 1

Revision: **NEW**

Stds Committee Approval:  
**Approved**



**Application:** Bayonet Fuses are used to protect transformers and distribution systems. They are designed for use in pad-mounted or subsurface distribution transformers filled with transformer oil. The assemblies can be removed with a hotstick.

Removal of the fuse holder from the assembly indicates that the apparatus is electrically disconnected. It also allows convenient fuse element inspection and replacement. When typical safety practices are followed, the assemblies can be loadbreak operated for working on the transformer secondary; changing distribution voltage with dual voltage switches or tap changers; or disconnecting the apparatus from the line.

**Packaging and Marking:** Items shall be suitably packaged to prevent damage. The container shall be convenient for handling and storage. Manufacturer's name or symbol and catalog number shall be on each part or (and) its packaging.

**Shipping:** Special Shipping Instructions

**Approved Manufacturers:**

PUD IDENTIFICATION		MANUFACTURER CATALOG NUMBER
Stock Description	Stock No.	Cooper Power
FUSE HOLDER, BAYONET FUSE	090255	4001030B52M



**FUSE LINKS, TYPE T OH DROPOUT**

Originator: DSmith

Date: 7/17/2006

Approval: DSmith

Date: 6/29/2007

Page 1 of 1

Revision: **NEW**

Stds Committee Approval:  
**Approved**



**Application:** This standard applies to links for high voltage fuses (above 600V) for enclosed and open link types for distribution cutouts.

**Specifications:** Distribution fuse links shall be the removable or solid buttonhead type meeting the following requirements.

Dimensions: All fuses shall be at least 23 inches long.

Strength: Fuses shall meet ANSI standard C37.42, latest revision. Fuses 10 through 100 amp size shall have non-damageable silver fusible elements.

**Packaging and Marking:** Items shall be suitably packaged to prevent damage. The container shall be convenient for handling and storage. Manufacturer's name or symbol and catalog number shall be on each part and its packaging. The part shall show rated continuous current followed by a type identification, STD, T, 200, or K.

PUD IDENTIFICATION		MANUFACTURER CATALOG NUMBER
Stock No.	Maximo Stock Description	S&C
017780	FUSE, TLINK, 6AMP	279006
017785	FUSE, TLINK, 8AMP	279008
017790	FUSE, TLINK, 10AMP	279010
017795	FUSE, TLINK, 12AMP	279012
017800	FUSE, TLINK, 15AMP	279015
017805	FUSE, TLINK, 20AMP	279020
017810	FUSE, TLINK, 25AMP	279025
017815	FUSE, TLINK, 30AMP	279030
017820	FUSE, TLINK, 40AMP	279040
017830	FUSE, TLINK, 50AMP	279050
018650	FUSE, TLINK, 65AMP	279065
018660	FUSE, TLINK, 80AMP	279080
018700	FUSE, TLINK, 100AMP	279100
018750	FUSE, TLINK, 140AMP	279140
018800	FUSE, TLINK, 200AMP	279200





**FUSE, CURRENT LIMITING DROPOUT  
(ELF FUSE)**

Originator: DSmith

Date: 7/17/2006

Approval: DSmith

Date: 6/29/2007

Page 1 of 1

Revision: **NEW**

Stds Committee Approval:  
**Approved**

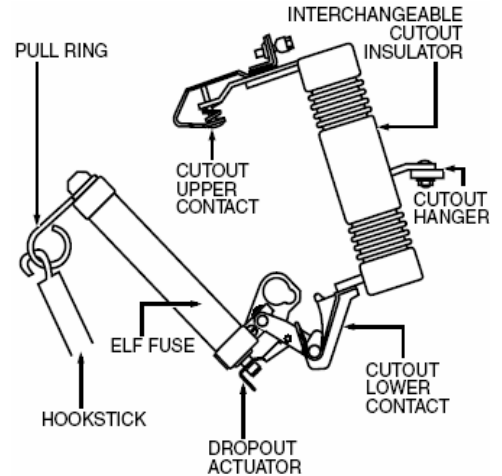

**Application:** This Current-Limiting Dropout Fuse is a full range current-limiting fuse designed for mounting in an industry standard interchangeable cutout that is presently used for expulsion fuses. The ELF fuse is designed to be used to protect poletype transformers, single-phase and three-phase laterals and underground taps.

The ELF dropout fuse operates silently, unlike expulsion fuses. In addition, the expulsive shower that exists with an expulsion fuse operation is eliminated. It is designed to be mounted in open distribution cutouts including S&C Type XS, A.B. Chance Type C, Joslyn Type L and ABB Type ICX cutouts. Refer to Cooper Product Literature 240-66

**Common Name:** ELF Fuses

**Packaging and Marking:** Items shall be suitably packaged to prevent damage. The container shall be convenient for handling and storage. Manufacturer's name or symbol and catalog number shall be on each part and/or its packaging.

**Approved Manufacturers:**

PUD IDENTIFICATION		MFG. CATALOG NUMBER
Stock Description	Stock No.	COOPER
FUSE, ELF, 18AMP, 8.3KV (CL DROPOUT FUSE)	17831	FAK23W18
FUSE, ELF, 25AMP, 8.3KV (CL DROPOUT FUSE)	17832	FAK23W25
FUSE, ELF, 30AMP, 8.3KV (CL DROPOUT FUSE)	17833	FAK23W30
FUSE, ELF, 50AMP, 8.3KV DBL BARREL DESIGN, (CL DROPOUT FUSE)	17834	FAK23W50
FUSE, ELF, 65AMP, 8.3KV DBL BARREL DESIGN, (CL DROPOUT FUSE)	17835	FAK23W65
FUSE, ELF, 6AMP, 15KV, 200AMP CUTOUPS, (CL DROPUT FUSE)	17836	FAK44W6
FUSE, ELF, 12AMP, 8.3KV (CL DROPOUT FUSE)	17837	FAK23W12



**FUSE, BAY-O-NET OIL-IMMERSED FUSE LINKS**

Originator: DSmith

Date: 7/17/2006

Approval: DSmith

Date: 7/5/2007

Page 1 of 1

Revision: **NEW**

Stds Committee Approval:  
**Approved**

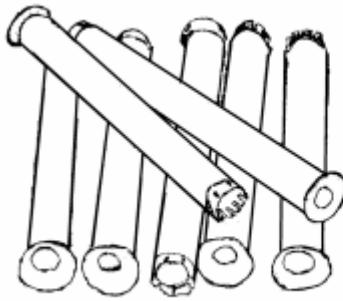

Figure 1

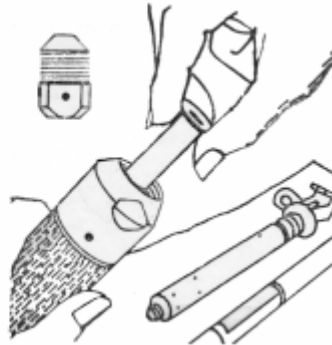

Figure 2

**Application:** The District uses the-Cooper Bay-o-net fault sensing fuse on pad and submersible type distribution transformers connected to 12.47kV feeders. An isolation link in series with the Bay-o-net fuse melts when exposed to fault currents in excess of the Bay-o-net rating. The Bay-o-net fuse has a replaceable cartridge.

**Packaging and Marking:** Replaceable fuse links shall be individually packaged in a container suitable for easy handling and storage. Each container shall be marked with MFR's name, catalog number, name of item and size contained.

M = Denotes Bag Of 50

B = Denotes Individual Units

**APPROVED MANUFACTURERS:**

PUD IDENTIFICATION			MANUFACTURER'S CATALOG NUMBER
Stock Description	Figure	Stock No.	Cooper
FUSE, BAYONET 3 AMP (Bag Of 50)	1	090260	4000358C03M
FUSE, BAYONET 8 AMP (Bag Of 50)	1	090270	4000358C05M
FUSE, BAYONET 15 AMP (Bag Of 50)	1	090280	4000358C08M
FUSE, BAYONET 25 AMP (Bag Of 50)	1	090290	4000358C10M
FUSE, BAYONET 50 AMP (Bag Of 50)	1	090300	4000358C12M
FUSE, BAYONET 65 AMP (Bag Of 50)	1	090310	4000358C14M
FUSE, BAYONET 100 AMP, High Amperage	2	090325	4038361C04CB
FUSE, BAYONET 125 AMP, High Amperage	2	090315	4038361C05CB



**FUSE, SM-4 (E)**

Originator: DSmith

Date: 7/7/06

Approval: DSmith

Date: 6/29/2007

Page 1 of 2

Revision: **NEW**

Stds Committee Approval:  
**PENDING**

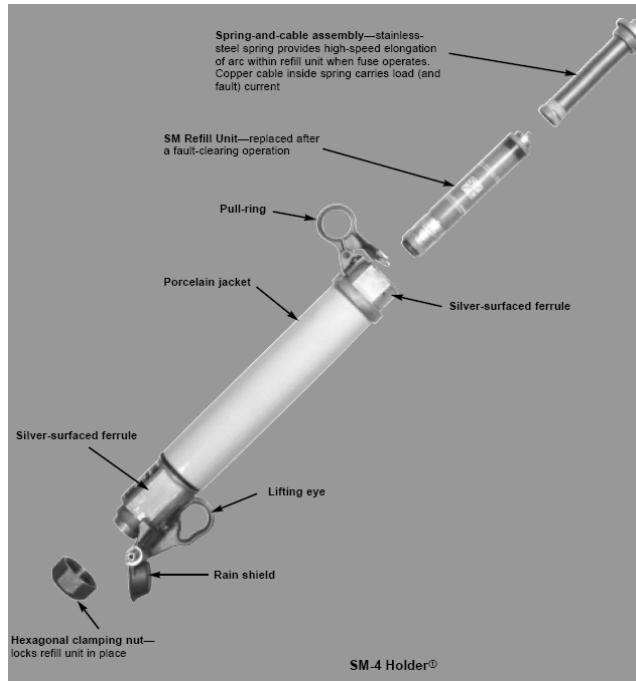

**Application:** Used in SM4 Fuse Holder Assemblies.

**Packaging and Marking:** Items shall be suitably packaged to prevent damage. The container shall be convenient for handling and storage. Manufacturer's name or symbol and catalog number shall be on each part or (and) its packaging.

**Shipping:** Special Shipping Instructions

**Approved Manufacturers:**

PUD IDENTIFICATION		MANUFACTURER CATALOG NUMBER
Stock No.	Stock Description	S & C
090000	FUSE, SM4, 14.4KV 15AMP, E SLOW	252025R4
090105	FUSE, SM4, 14.4KV 20AMP, E SLOW	252030R4
090010	FUSE, SM4, 14.4KV 25AMP, E SLOW	252040R4
090015	FUSE, SM4, 14.4KV 30AMP, E SLOW	252050R4
090020	FUSE, SM4, 14.4KV 40AMP, E SLOW	252060R4
090121	FUSE, SM4, 14.4KV 50AMP, E SLOW	252075R4
090030	FUSE, SM4, 14.4KV 65AMP, E SLOW	252100R4
090040	FUSE, SM4, 14.4KV 80AMP, E SLOW	252125R4
090050	FUSE, SM4, 14.4KV 100AMP, E SLOW	252150R4



**FUSE, SM-4 (E)**

Originator: DSmith

Date: 7/7/06

Approval: DSmith

Date: 6/29/2007

Revision: **NEW**

Stds Committee Approval:  
**PENDING**

090060	FUSE, SM4, 14.4KV 125AMP, E SLOW	252200R4
090070	FUSE, SM4, 14.4KV 150AMP, E SLOW	252250R4
090080	FUSE, SM4, 14.4KV 175AMP, E SLOW	252275R4
090090	FUSE, SM4, 14.4KV 200AMP, E SLOW	252300R4
090100	FUSE, SM4, 14.4KV 15AMP, E STD	122025R4
090110	FUSE, SM4, 14.4KV 25AMP, E STD	122040R4
090120	FUSE, SM4, 14.4KV 40AMP, E STD	122060R4
090130	FUSE, SM4, 14.4KV 65AMP, E STD	122100R4
090140	FUSE, SM4, 14.4KV 80AMP, E STD	122125R4
090150	FUSE, SM4, 14.4KV 100AMP, E STD	122150R4
090160	FUSE, SM4, 14.4KV 125AMP, E STD	122200R4
090170	FUSE, SM4, 14.4KV 150AMP, E STD	122250R4
090180	FUSE, SM4, 14.4KV 175AMP, E STD	122275R4
090190	FUSE, SM4, 14.4KV 200AMP, E STD	122300R4
090210	FUSE, SM4, 14.4KV 250AMP, E STD	122400R4



# FUSE, SMU20 POWER UNITS

Originator: DSmith

Date: 7/26/2006

Approval: J Mitchell

Date: 8/10/11

Page 1 of 1

Revision: Misc.

Stds Committee Approval: **Approved**



**Application:** Primarily used inside substations for fusing station service transformers, Potential Transformers, or other equipment where higher fault currents are present.

**Packaging and Marking:** Items shall be suitably packaged to prevent damage. The container shall be convenient for handling and storage. Manufacturer's name or symbol and catalog number shall be on each part or (and) its packaging.

**Shipping:** No Special Shipping Instructions

### Approved Manufacturers:

PUD IDENTIFICATION		MANUFACTURER CATALOG NUMBER
Stock Description	Stock No.	S & C
FUSE, SUBSTATION P.T.	032394	702001
FUSE, SUBSTATION XFMR	032396	612005
FUSE, SMD20, 14.4KV 80AMP, E STD	090220	612080
FUSE, SMU20, 14.4KV 3AMP, "K"	090230	702003
FUSE, SMU20, 24.4KV 150AMP, E SLOW	090250	612150
MOUNTINGS, SMD20	032392	92122R3-DON



**SOLID DISCONNECT BLADE , DOOR**

Originator: DSmith

Date: 7/26/2006

Approval: DSmith

Date: 6/29/2007

Page 1 of 1

Revision: **NEW**

Stds Committee Approval:  
**Approved**

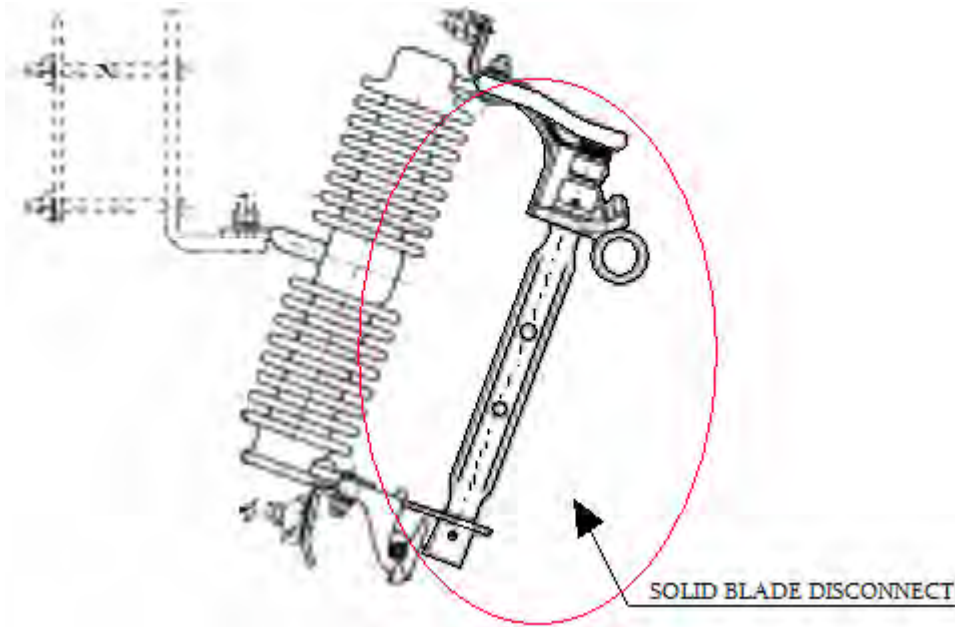

**Application:** Used in standard 100A and 200A cutouts as a high amperage switch.

**Packaging and Marking:** Items shall be suitably packaged to prevent damage. The container shall be convenient for handling and storage. Manufacturer's name or symbol and catalog number shall be on each part or (and) its packaging.

**Approved Manufacturers:**

PUD IDENTIFICATION		MANUFACTURER CATALOG NUMBER
Stock Description	Stock No.	S & C
DOOR, SOLID BLADE ONLY, 15KV, 100AMP CUTOUT	017100	89621R10
DOOR, SOLID BLADE ONLY, 15KV, 200AMP CUTOUT	017110	89622R10



**FUSE, NX-TYPE, ARC STRANGLER**

Originator: DSmith

Date: 7/26/2006

Approval: DSmith

Date: 6/29/2007

Page 1 of 2

Revision: **NEW**

Stds Committee Approval:  
**Approved**



Clip Style NX Fuse



Arc Strangler NX Fuse



Arc Strangler Switchblade

**Application:** Current Limiting type fuses or solid switchblade used in live front padmounted switch cabinets

**Packaging and Marking:** Items shall be suitably packaged to prevent damage. The container shall be convenient for handling and storage. Manufacturer's name or symbol and catalog number shall be on each part or (and) its packaging.

PUD IDENTIFICATION		MANUFACTURER CATALOG NUMBER
Stock Description	Stock No.	Cooper Power
FUSE, ARC STRANGLER, NX, 8KV 6 AMP	090540	FA3A6
FUSE, ARC STRANGLER, NX, 8KV 8 AMP	090550	FA3A8
FUSE, ARC STRANGLER, NX, 8KV 10 AMP	090560	FA3A10
FUSE, ARC STRANGLER, NX, 8KV 12 AMP	090570	FA3A12
FUSE, ARC STRANGLER, NX, 8KV 18 AMP	090580	FA3A18
FUSE, ARC STRANGLER, NX, 8KV 25 AMP	090590	FA3A25
FUSE, ARC STRANGLER, NX, 8KV 30 AMP	090600	FA3A30
FUSE, ARC STRANGLER, NX, 8KV 40 AMP	090610	FA3A40





**FUSE, NX-TYPE, ARC STRANGLER**

Originator: DSmith

Date: 7/26/2006

Approval: DSmith

Date: 6/29/2007

Page 2 of 2

Revision: **NEW**

Stds Committee Approval:  
**Approved**

FUSE, ARC STRANGLER, NX, 15KV 6 AMP	090620	FA4A6
FUSE, ARC STRANGLER, NX, 15KV 8 AMP	090630	FA4A8
FUSE, ARC STRANGLER, NX, 15KV 10 AMP	090640	FA4A10
FUSE, ARC STRANGLER, NX, 15KV 12 AMP	090650	FA4A12
FUSE, ARC STRANGLER, NX, 15KV 18 AMP	090660	FA4A18
FUSE, ARC STRANGLER, NX, 15KV 25 AMP	090670	FA4A25
FUSE, ARC STRANGLER, NX, 15KV 30 AMP	090680	FA4A30
FUSE, ARC STRANGLER, NX, 15KV 40 AMP	090690	FA4A40
FUSE, CLIP STYLE, NX, 8KV 6 AMP	090700	FA3H6
FUSE, CLIP STYLE, NX, 8KV 8 AMP	090710	FA3H8
FUSE, CLIP STYLE, NX, 8KV 10 AMP	090720	FA3H10
FUSE, CLIP STYLE, NX, 8KV 12 AMP	090730	FA3H12
FUSE, CLIP STYLE, NX, 8KV 18 AMP	090740	FA3H18
FUSE, CLIP STYLE, NX, 8KV 25 AMP	090750	FA3H25
FUSE, CLIP STYLE, NX, 8KV 30 AMP	090760	FA3H30
FUSE, CLIP STYLE, NX, 8KV 40 AMP	090770	FA3H40
FUSE, CLIP STYLE, NX, 15KV 6 AMP	090780	FA4H6
FUSE, CLIP STYLE, NX, 15KV 8 AMP	090790	FA4H8
FUSE, CLIP STYLE, NX, 15KV 10 AMP	090800	FA4H10
FUSE, CLIP STYLE, NX, 15KV 12 AMP	090810	FA4H12
FUSE, CLIP STYLE, NX, 15KV 18 AMP	090820	FA4H18
FUSE, CLIP STYLE, NX, 15KV 25 AMP	090830	FA4H25
FUSE, CLIP STYLE, NX, 15KV 30 AMP	090840	FA4H30
FUSE, CLIP STYLE, NX, 15KV 40 AMP	090850	FA4H40
FUSE, CLIP STYLE, NX, 15KV 50 AMP	090855	FA4H50
FUSE, CLIP STYLE, NX, 15KV 65 AMP	090860	FA4H65
FUSE, CLIP STYLE, NX, 15KV 80 AMP	090870	FA4H80
FUSE, CLIP STYLE, NX, 15KV 100 AMP	090880	FA4H100
FUSE, ARC STRANGLER SWITCHBLADE, 8KV 200A	090890	FA1B1
FUSE, ARC STRANGLER SWITCHBLADE, 15KV 200A, SHORT	090900	FA4B1
FUSE, ARC STRANGLER SWITCHBLADE, 15KV 200A, LONG	090910	FA3B1
FUSE, TANDEM, MT-NX, 15KV 80 AMP	09020	FA11A80



**FAULT FITER, ETP FUSE**

Originator: DSmith

Date: 7/17/2006

Approval: DSmith

Date: 6/29/2007

Page 1 of 1

Revision: **NEW**

Stds Committee Approval:  
**Approved**



**Application:** Backup current-limiting fuses designed to protect transformers are used in series with another protective device (such as an expulsion fuse). This combination limits the high-fault current to a safe level, thus providing protection through the complete range. As its name implies, the "ETP" is for External Transformer Protection.

For conventional transformers protected by expulsion-fuse cutouts, the ETP can be installed in series with the cutout. For self-protected transformers, the ETP can be applied on the high-voltage bushing in series with the internal transformer expulsion fuse. From 8.3kV to 23kV and from 8T to 80K

**Approved Manufacturers:**

PUD IDENTIFICATION		MANUFACTURER CATALOG NUMBER
Stock Description	Stock No.	GE
FUSE, CURRENT LIMITING, 1-15KVA OH TRANSFORMER, USE WITH CUTOUT, (FAULT FITER "A" RANGE #5521)	045410	9F59UBC131
FUSE, CURRENT LIMITING, 25-50KVA OH TRANSFORMER, USE WITH CUTOUT, (FAULT FITER "B" RANGE #5522)	045420	9F59UBC132
FUSE, CURRENT LIMITING, OH 75KVA UP TRANSFORMER, USE WITH CUTOUT, (FAULT FITER "C" RANGE #5523)	045430	9F59UBC134



**FAULT INDICATORS, OVERHEAD**

Originator: DSmith

Date: 7/28/2006

Approval: DSmith

Date: 11/1/2007

Page 1 of 1

Revision: **NEW**

Stds Committee Approval:  
**APPROVED**



**Application:** These devices are electric field reset fault indicators (type ERL) derive their operating power from the potential gradient around high-voltage power lines. The ERL's inrush restraint option blocks targeting for recloser operations. When the upstream protection operates, the indicator senses the collapse of the voltage field and prohibits tripping until the utility is able to restore normal system conditions

**Packaging and Marking:** Items shall be suitably packaged to prevent damage. The container shall be convenient for handling and storage. Manufacturer's name or symbol and catalog number shall be on each part or (and) its packaging.

**Approved Manufacturers:**

PUD IDENTIFICATION		MANUFACTURER CATALOG NUMBER	
Stock Description	Stock No.	SEL	
FAULT INDICATOR, 450 AMP, AUTO RESET, OVERHEAD, WITH INRUSH RESTRAINT	017500	ERL0400-IR	
FAULT INDICATOR, 800 AMP, AUTO RESET, OVERHEAD	017550	8125604A57M	



**FAULT INDICATOR**  
**15kV URD Elbow Test Point**  
**Voltage Reset**

Originator: DSmith

Date: 6/29/2007

Approval: DSmith

Date: 6/29/2007

Page 1 of 1

Revision: **NEW**

Stds Committee Approval:

**Approved**



**Application:** These units are used on 200 and 600 A class underground distribution systems whose terminators have test points. The unit requires a 5 kV phase-to-ground minimum voltage to reset and remain ready to trip. Its target, built into the sensor housing itself, automatically resets when system voltage returns to normal. The conductive, EPDM rubber housing maintains the separable connector system's ground shielding. The unit operates independently of load current.

The unit's inrush restraint feature blocks tripping that might result from reclosing operations. When the breaker or recloser opens, the unit senses a loss of voltage on the test point. The unit blocks the display from targeting if the subsequent inrush current exceeds the trip value. It is ready to trip a few minutes after reenergization.

**Packaging and Marking:** Items shall be suitably packaged to prevent damage. The container shall be convenient for handling and storage. Manufacturer's name or symbol and catalog number shall be on each part or (and) its packaging.

**Approved Manufacturers:**

PUD IDENTIFICATION		MANUFACTURER CATALOG NUMBER
Stock Description	Stock No.	Schweitzer Engineering Laboratories
FAULT IND, ELBOW TEST PT, 15KV, 200AMP VOLTAGE RESET	045470	1TPRI0200J
FAULT IND, ELBOW TEST PT, 15KV, 450AMP VOLTAGE RESET	045480	ITPRI0450J
FAULT IND, ELBOW TEST PT, 15KV, 800AMP VOLTAGE RESET	045481	1TPRI-0800J



# SWITCHGEAR

Originator: DSmith

Date: 7/9/2007

Approval: DSmith

Date: 7/9/2007

Page 1 of 1

Revision: **NEW**

Stds Committee Approval:  
**Approved**

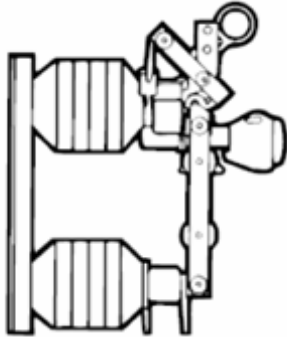

# SWITCHGEAR





**SWITCH, DISCONNECT SPST  
Crossarm Mounted  
15kV, 600 Amp**

Originator: DSmith

Date: 7/9/2013

Approval: J. Nleborsky

Date: 7/9/2013

Page 1 of 1

Revision: **Added Cooper Catalog Number**

Stds Committee Approval:

**Approved**

**Application:** Loadbuster Disconnects are designed for use with Loadbuster, S&C's portable loadbreak tool, which has an interrupting rating of 600 amperes nominal, 900 amperes maximum.

When used with Loadbuster, the disconnects are suitable for these single-phase live-switching duties on single-phase or three-phase circuits of overhead distribution systems: They can be mounted either vertically or horizontally.



**Specification:** Each switch shall have the following ratings:

**Equipped:** With Loadbuster hooks for operation with an S & C Loadbuster tool.

**Electrical Rating:** Switch shall be capable of conducting 600 amps continuous, 30,000 amps momentary in the bypass position.

**Insulators:** Shall be NEMA standard posts **non porcelain** suitable for outdoor operation.

**Terminal Pads:** Shall be NEMA standard with two 9/16 inch diameter holes on 1-3/4 inch centers.

**Base:** Shall Be Structural Steel Channel Approximately 5 Inches Wide Carriage Bolt Slots And A Backing Plate Suitable For Mounting Either Vertically Or Horizontally. Base Shall Be Hot-Dipped Galvanized After Fabrication Per Latest Revision Of Astm A-153.

**Packaging and Marking:** Items shall be suitably packaged to prevent damage. The container shall be convenient for handling and storage. Manufacturer's name or symbol and catalog number shall be on each part or it packaging.

**Accepted Manufacturers: S&C, Cooper Power Systems**

Stock Description	Stock No.	S&C	Cooper
SWITCH, DISCONNECT 600A 15KV, SPST	016150	4922R9-E	D73P16S0



**Switch Operating Platform**  
**4' X 6" Galvanized**

Originator: WSweeny

Date: 6/29/2007

Approval: DSmith

Date: 6/29/2007

Page 1 of 1

Revision: **NEW**

Stds Committee Approval:

**Approved**

**Refer To Manufactures Drawing 05-WW-05, Dated 03/09/05**  
**Galvanizers, INC**  
**1202 Seventh Avenue North**  
**West Fargo, ND 58078**  
**(701) 282-3906**

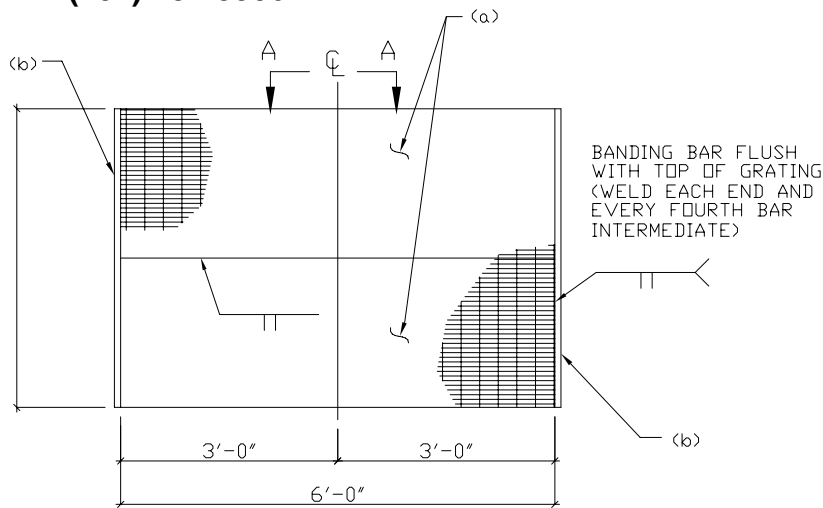

BANDING BAR FLUSH WITH TOP OF GRATING (WELD EACH END AND EVERY FOURTH BAR INTERMEDIATE)

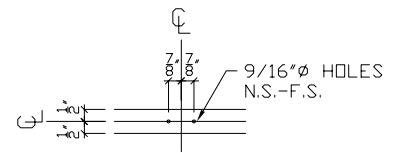

SECTION A-A

NOTES:

1. ALL STEEL - ASTM A36 U.N.D.
2. GALV. AFTER FABRICATION PER ASTM A123
3. SMOOTH GRATING -  
1" x 3/16" BARS  
1 3/16" C TO C W/  
4" C TO C CROSSBARS

WELDMENT 05

**Application:** Used for grounding 15kV & 115Kv 3 Phase OH Switches with Ground Mounted Switch handle. Weight is 186.7 lbs.

**Packaging and Marking:** Items shall be suitably packaged to prevent damage. The container shall be convenient for handling and storage. Manufacturer's name or symbol and catalog number shall be on each part or (and) its packaging.

**Approved Manufacturers:**

PUD IDENTIFICATION		MANUFACTURER CATALOG NUMBER		
Stock Description	Stock No.	Galvanizers, INC	MFG #3	MFG #3
Switch Operating Platform - Galvanized	026205	05-WW-05	XXXXX	XXXXX





# SWITCH, REGULATOR BYPASS Sequenced

Originator: DSmith

Date: 6/29/2007

Approval: DSmith

Date: 6/29/2007

Page 1 of 1

Revision: **NEW**

Stds Committee Approval:  
**Approved**

**Application:** A single-phase regulator bypass switch (bypass-disconnect) is used to bypass a regulator before isolating it from the circuit. The operation requires a single stroke and will not interrupt customer service. The closing stroke puts the regulator back into service before the bypass is removed.

**Specification:** The Voltage regulator bypass switch shall be equipped with a device for interrupting regulator exciting current with no exposed arcing and meeting the following additional requirements.

**Electrical Rating:** Switch shall be capable of conducting 600 amps continuous, 30,000 amps momentary in the bypass position.

**Insulators:** Shall be NEMA standard posts suitable for outdoor operation.

**Terminal Pads:** Shall be NEMA standard with two 9/16 inch diameter holes on 1-3/4 inch centers.

**Base:** Shall be structural steel channel approximately 9 inches wide with 9/16 inch diameter holes for mounting bolts. Base shall be hot-dipped galvanized after fabrication per latest revision of ASTM A-153.

**Packaging and Marking:** Items shall be suitably packaged to prevent damage. The container shall be convenient for handling and storage. Manufacturer's name or symbol and catalog number shall be on each part or its packaging.

**Accepted Manufacturers: Cooper Power Systems, S&C**

PUD IDENTIFICATION		MANUFACTURER CATALOG NUMBER	
Stock No.	Maximo Stock Description	Cooper	S&C
032560	SWITCH, BYPASS, 600AMP REGULATOR, DISCONNECT, VERTICAL MOUNT	125821-20	333412R7

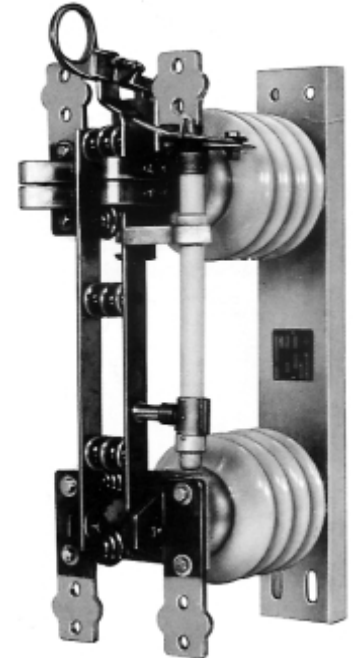



# Switchgear, Pad-Mounted 15kv Air-Insulated Live-Front

Originator: DSmith

Date: 7/20/2009

Approval: DSmith

Date: 7/20/2009

Page 1 of 1

Revision: **NEW**

Stds Committee Approval:  
**Approved**

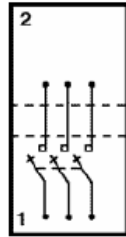

PM-3

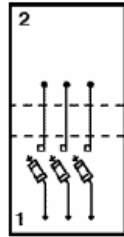

PM-4

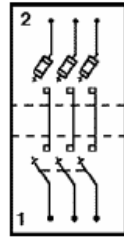

PM-5

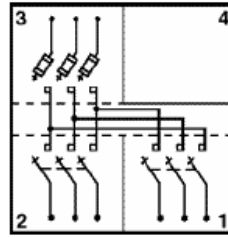

PM-6

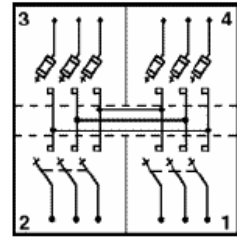

PM-9

**Application:** This switchgear will be used for sectionalizing and protecting underground distribution express feeders, sub-loops, and laterals as well as switching and protecting transformers.

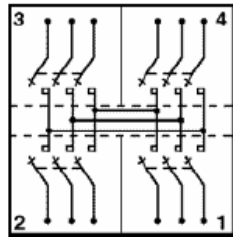

PM-10

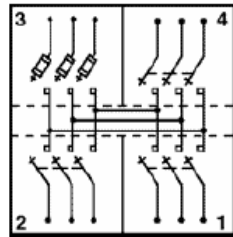

PM-11

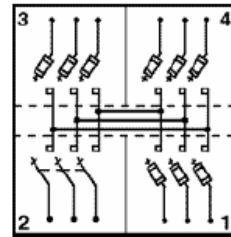

PM-12

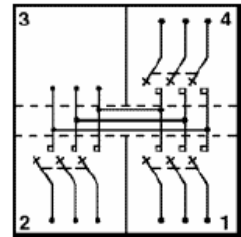

PM-13

**Specification:** Refer to Equipment Specification #1513.01 which covers the requirements for furnishing and delivering free-standing, self-contained, cabinet enclosed 15kV rated air-insulated live-front pad-mounted switchgear with 600 amp interrupter switches and/or 200 amp fuses with integral load interrupters. This switchgear is intended for use in 60 hertz, three-phase, 12470 volt grounded-WYE underground distribution systems. This switchgear shall be designed for outdoor installation and operation and for mounting on a concrete pad or fiberglass ground sleeve.

**Approved Manufactures; S&C or Federal Pacific**

PUD IDENTIFICATION		
Stock Description	Stock	Style
Switch, Padmt Livefront, 15kV, PM3, 1-600A SW, No Fused Compartments	049416	PM-3
Switch, Padmt Livefront, 15kV, PM4, No SW, 1-200a Fused Compartments	049418	PM-4
Switch, Padmt Livefront, 15kV, PM5, 1-600A SW, 1-200a Fused Compartment	049414	PM-5
Switch, Padmt Livefront, 15kV, PM6, 2-600A SW, 1-200a Fused Compartment	049415	PM-6
Switch, Padmt Livefront, 15kV, PM9, 2-600A SW, 2-200a Fused Compartments	049420	PM-9
Switch, Padmt Livefront, 15kV, PM10, 4-600A SW, No Fuses	049417	PM-10
Switch, Padmt Livefront, 15kV, PM11, 3-600A SW, 1-200a Fused Compartments	049425	PM-11
Switch, Padmt Livefront, 15kV, PM12, 1 600A SW, 3-200a Fused Compartments	049426	PM-12
Switch, Padmt Livefront, 15kV, PM13, 3- 600A SW & No Fuses	049430	PM-13



# LINE HARDWARE

Originator: DSmith

Date: 1/24/2007

Approval: DSmith

Date: 1/24/2007

Page 1 of 1

Revision: **NEW**

Stds Committee Approval:  
**Approved**



# SECTION 1600 LINE HARDWARE

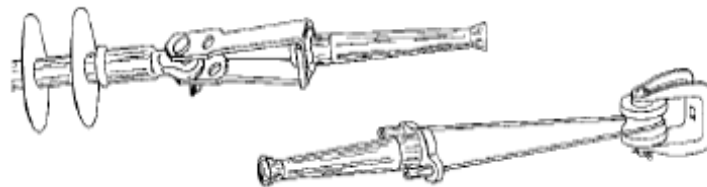
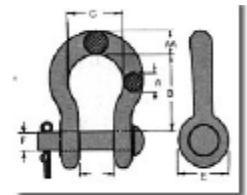



**LINE HARDWARE, ARMOR RODS, ACSR/AAC**

Originator: DSmith

Date: 7/7/06

Approval: DSmith

Date:  
**10/29/2009**  
~~7/5/2007~~

Page 1 of 1

Revision: **NEW**

Std's Committee Approval:  
**Approved**

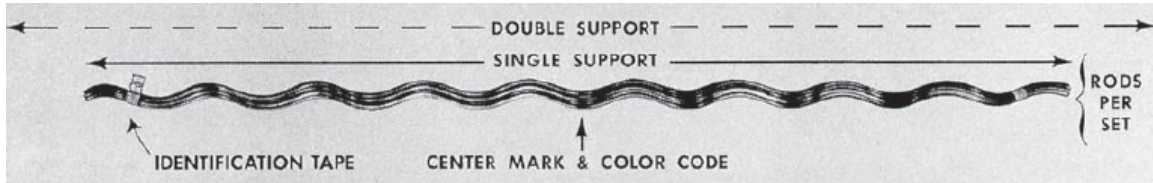

**Application:** Used to prevent wear on conductor State description and purpose of item, how it is used, any precaution associated with its use and any exceptional salvage instructions.

**Packaging and Marking:** Items shall be suitably packaged to prevent damage. The container shall be convenient for handling and storage. Manufacturer's name or symbol and catalog number shall be on each part or (and) its packaging.

**Approved Manufacturers:**

PUD IDENTIFICATION		MANUFACTURER CATALOG NUMBER
Stock Description	Stock No.	Preformed Line Products
<del>ARMOR ROD, #2/0 ACSR, BLUE</del>	<del>028080</del>	<del>AR-0120</del>
<del>ARMOR ROD, #4/0 ACSR, RED</del>	<del>028100</del>	<del>AR-0124</del>
ARMOR ROD, 266KCM ACSR, YELLOW	028140	AR-0127
<del>ARMOR ROD, 336KCM ACSR, GREEN</del>	<del>028150</del>	<del>AR-0130</del>
<del>ARMOR ROD, 636KCM ACSR, YELLOW</del>	<del>028170</del>	<del>AR-0137</del>
ARMOR ROD, #2/0 AAC, BROWN	028200	AR-0119
ARMOR ROD, #4/0 AAC, BLACK	028220	AR-0123
<del>ARMOR ROD, 336KCM AAC, BROWN</del>	<del>028250</del>	<del>AR-0128</del>
<del>ARMOR ROD, 636KCM AAC, GREEN</del>	<del>028270</del>	<del>AR-0135</del>
<del>ARMOR ROD, 954KCM AAC, ORANGE</del>	<del>028280</del>	<del>AR-0141</del>



**LINE HARDWARE, DOUBLE SIDE TIES**

Originator: DSmith

Date: 7/26/2006

Approval: DSmith

Date: 7/5/2007

Page 1 of 1

Revision: **NEW**

Std's Committee Approval:  
**Approved**

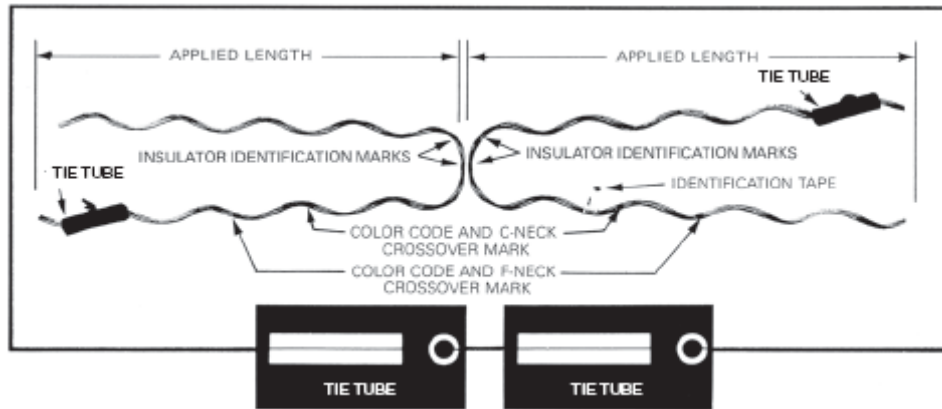

**Application:** The double side tie is designed to secure conductors on double-arm construction in the side groove of interchangeable headstyle insulators. They are intended for larger line angles than top groove style ties, such as, Double-Support Ties.

**Packaging and Marking:** Items shall be suitably packaged to prevent damage. The container shall be convenient for handling and storage. Manufacturer's name or symbol and catalog number shall be on each part or (and) its packaging.

**Approved Manufacturers:**

PUD IDENTIFICATION		MANUFACTURER CATALOG NUMBER	
Stock Description	Stock No.	Preformed Line Products	DULMISON
TIE, DOUBLE SIDE, #2 ACSR RED, W/ 2-1/4" AND 2-7/8" NECK DIA	037330	DBST-1102	DBST-0805
TIE, DOUBLE SIDE, 2/0 ACSR BLUE	037410	DBST-1104	DBST-1030
TIE, DOUBLE SIDE, 336KCM ACSR BROWN, W/ 2-1/4" AND 2-7/8" NECK DIA	037480	DBST-1108	DBST-1695
TIE, DOUBLE SIDE, #4/0 AAC, RED W/ 2-1/4" AND 2-7/8" NECK DIA	037760	DBST-1106	DBST-1325
TIE, DOUBLE SIDE, 266KCM AAC, PURPLE W/ 2-1/4" AND 2-7/8" NECK DIA	037880	DBST-1107	DBST-1495
TIE, DOUBLE SIDE, 636KCM AAC BLUE, W/ 2-1/4" AND 2-7/8" NECK DIA	037920	DBST-1110	DBST-2175



**LINE HARDWARE, DOUBLE TOP TIES**

Originator: DSmith

Date: 7/26/2006

Approval: DSmith

Date: 7/5/2007

Page 1 of 1

Revision: **NEW**

Stds Committee Approval:

**Approved**



**Application:** The double top tie is designed to secure conductors on double-arm construction in the top groove of interchangeable pin style insulators. They are intended for larger line angles than single top groove style ties..

**Packaging and Marking:** Items shall be suitably packaged to prevent damage. The container shall be convenient for handling and storage. Manufacturer's name or symbol and catalog number shall be on each part or (and) its packaging.

**Approved Manufacturers:**

PUD IDENTIFICATION		MANUFACTURER CATALOG NUMBER	
Stock Description	Stock No.	Preformed Line (PLP)	DULMISON
TIE, DBL TOP, #2 ACSR, RED PIN INSLTR W/ 2-1/2" AND 2-7/8" NECK DIA.	037340	DST-0152	DSTCF-0800
TIE, DBL TOP, #4/0 ACSR, RED PIN INSLTR W/ 2-1/2" AND 2-7/8" NECK DIA.	037350	DST-0156	DSTCF-1325
TIE, DBL TOP, 336KCM ACSR, BROWN PIN INSLTR W/ 2-1/2" AND 2-7/8" NECK DIA.	037390	-----	DSTCF-1696
TIE, DBL TOP, 636KCM ACSR, BLUE PIN INSLTR W/ 2-1/2" AND 2-7/8" NECK DIA.	037950	DST-0160	DSTCF-2175





**LINE HARDWARE, SPOOL TIES**

Originator: DSmith

Date: 7/26/2006

Approval: DSmith

Date: 7/9/2007

Page 1 of 1

Revision: **NEW**

Stds Committee Approval:

**Approved**

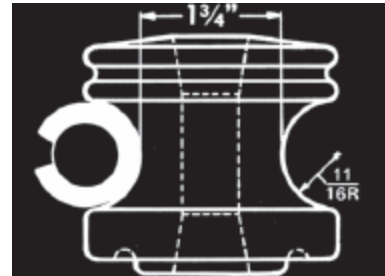

**Application:** A Spool Tie Assembly consists of one metal tie component plus tie tube. Spool ties are designed to be looped around a spool insulator mounted to a distribution pole and then twisted around the service wire neutral (messenger) to provide longitudinal support. Each spool tie is supplied with an electrometric tie tube designed to minimize abrasion to the insulator.

**Specification:** Each tie shall be suitable for use with ACSR, AAC, & AAAC conductor and suitable for use on ANSI 53-1,2, & 3 insulators with a 1-3/4" diameter neck. The strength of the tie shall be equal to or exceed the conductor strength.

**Packaging and Marking:** Items shall be suitably packaged to prevent damage. The container shall be convenient for handling and storage. Manufacturer's name or symbol and catalog number, applicable conductor size and color code shall be on each part.

**Approved Manufacturers:**

PUD IDENTIFICATION		MANUFACTURER CATALOG NUMBER	
Stock Description	Stock No.	PLP	DULMISON
Tie, Spool, #4 ACSR, Insulator W/ 1-3/4" Neck Diameter, Orange	037230	SPL-1352-P	SPL-0620-P
Tie, Spool, #2 ACSR Insulator W/ 1-3/4" Neck Diameter, Red	037350	SPL-1354-P	SPL-0800-P
Tie, Spool, #2/0 ACSR/AAC Insulator W/ 1-3/4" Neck Diameter, Blue	037400	SPL-1356-P	SPL-1030-P
Tie, Spool, #4/0 ACSR/AAC Insulator W/ 1-3/4" Neck Diameter, Red	037440	SPL-1358-P	SPL-1325-P
Tie, Spool, 336kcm ACSR/AAC, Insulator W/ 1-3/4" Neck Diameter, Brown	037870	SPL-1360-P	SPL-1695-P





**DEADEND, SERVICE GRIP**

Originator: DSmith

Date: 7/26/2006

Approval: DSmith

Date: 6/23/2010

Page 1 of 1

Revision: **NEW**

Stds Committee Approval:  
**Approved**

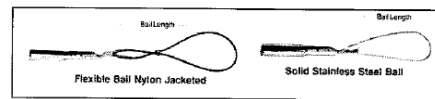
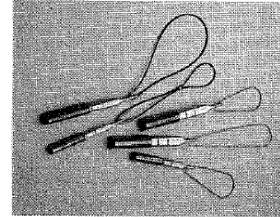

**Application:** Service-Grip dead-ends are manufactured of aluminum-covered steel are designed for bare neutral messengers of self-supporting cable used in making service drops. The dead-end is recommended for service drops by reason of minimum length, economy, and neatness of appearance. Mechanical strength meets the requirements for NESC Grade "N", Rule 263-E, Supply Services, Spans not exceeding 150 feet. For service drops exceeding 150 feet, Grade "C" Construction, the Distribution Grip dead-end is recommended.

**Specification:** Each grip shall be suitable for use with ACSR, AAC, & AAAC conductor and suitable for use on ANSI 53-1,2, & 3 insulators with a 1-3/4" diameter neck. The strength of the tie shall be equal to or exceed the conductor strength.

**Packaging and Marking:** Items shall be suitably packaged to prevent damage. The container shall be convenient for handling and storage. Manufacturer's name or symbol and catalog number, applicable conductor size and color code shall be on each part.

**Approved Manufacturers:**

PUD IDENTIFICATION		MANUFACTURER CATALOG NUMBER		
Stock Description	Stock No.	PLP	DULMISON	MACLEAN
Deadend, Service, #4 Str Wire (#2 Triplex) AAC ACSR, AWAC, Holding Strength 1144lb	016250	SG-4502	SG-0570	
Deadend, Service, #2 Str Wire (#2 Quad) AAC, ACSR, AWAC, Holding Strength 1395lb	016260	SG-4504	SPL-0800-P	
Deadend, Service, #1 Str Wire (2/0 Triplex) Al, ACSR, AWAC, Holding Strength 1740lb	016270	SG-4505	SG-0830	
Deadend, Service, #2/0 Str, Wire (2/0 Quad, #4/0 Trplx) AAC, ACSR, AWAC	016280	SG-4507	SG-1020	
Deadend, Service, #4/0 Str, Wire (4/0 Quad) AAC, ACSR, AWAC, Holding Strength 3300lb	016290	SG-4509		
Clamp, Wedge, Hard Bail, 11" Long, fits #4 du, fits 4/0 triplex and quad OH	016278			7198
Clamp, Wedge, Hard Bail, 6 1/2" Long, #2 & 2/0 triplex OH	016255			7195



**SINGLE SIDE TIES**

Originator: DSmith

Date: 7/27/2006

Approval: DSmith

Date: 7/5/2007

Page 1 of 1

Revision: **NEW**

Stds Committee Approval:  
**Approved**

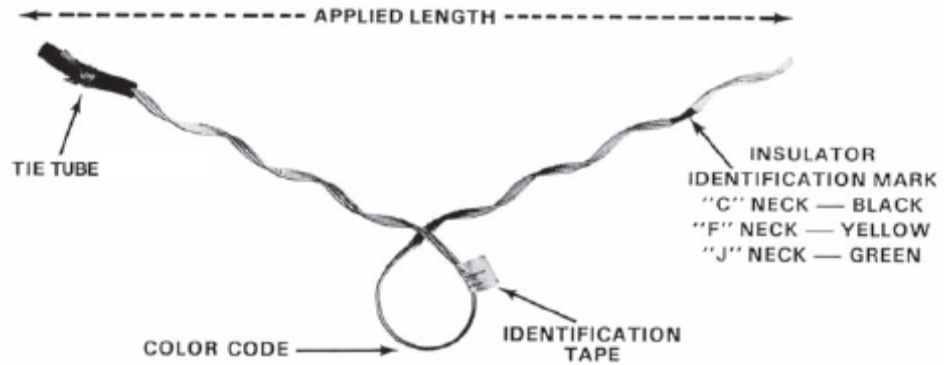
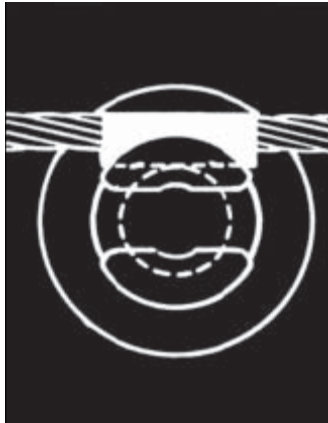

**Application:** Side Ties manufactured of aluminum covered steel secure conductors in the side groove of insulators. Side Ties provide an improved method of securing conductor compared to clamp-top insulators or hand ties over Armor Rods.

**Packaging and Marking:** Items shall be suitably packaged to prevent damage. The container shall be convenient for handling and storage. Manufacturer's name or symbol and catalog number shall be on each part or (and) its packaging.

**Approved Manufacturers:**

PUD IDENTIFICATION		MANUFACTURER CATALOG NUMBER	
Stock Description	Stock No.	PLP	DULMISON
TIE, SIDE, #2 ACSR RED PIN INSULATOR W/ 2-1/4" NECK DIAMETER	037300	STC-1254-P	STC-0805-P
TIE, SIDE, #2/0 ACSR BLUE PIN INSULATOR W/ 2-1/4" NECK DIAMETER	037390	STC-1256-P	STC-1030-P
TIE, SIDE, #4/0 ACSR RED PIN INSULATOR W/ 2-1/4" NECK DIAMETER	037430	STC-1258-P	STC-1325-P
TIE, SIDE, 336KCM ACSR BROWN PIN INSULATOR W/ 2-1/4" NECK DIAMETER	037470	STC-1260-P	STC-1695-P
TIE, SIDE, 266ACSR/336AAC PURPLE PIN INSULATOR W/ 2-1/4" NECK DIAMETER	037850	STC-1259-P	STC-1495-P
TIE, SIDE, 636KCM ACSR BLUE PIN INSULATOR W/ 2-1/4" NECK DIAMETER	037910	STC-1262-P	TBD



**TOP TIES**

Originator: DSmith

Date: 7/27/2006

Approval: J Mitchell

02/23/2015

Page 1 of 1

Revision: **Stock # for 636**

Stds Committee Approval:  
**Approved**

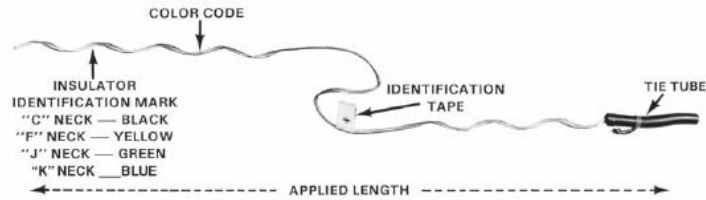

**Application:** On vertically-mounted insulators, Distribution Ties can normally accommodate line angles up to **10°**. This product is intended for a single (one-time) use and for the specified application. **CAUTION: DO NOT REUSE OR MODIFY THIS PRODUCT UNDER ANY CIRCUMSTANCES.**

**Packaging and Marking:** Items shall be suitably packaged to prevent damage. The container shall be convenient for handling and storage. Manufacturer's name or symbol and catalog number shall be on each part or (and) its packaging.

**Approved Manufacturers:**

PUD IDENTIFICATION		MANUFACTURER CATALOG NUMBER	
Stock Description	Stock No.	PLP	DULMISON
TIE, TOP, #4 ACSR/AAC ORANGE	037210	UTC-1102	DTC-0620-P
TIE, TOP, #2 ACSR/AAC RED	037250	UTC-1104	DTC-0805-P
TIE, TOP, #2/0 ACSR/AAC BLUE	037380	UTC-1106	DTC-1030-P
TIE, TOP, #4/0 ACSR/AAC RED	037420	UTC-1108	DTC-1325-P
TIE, TOP, #336 ACSR/397AAC BROWN	037460	UTC-1110	DTC-1695-P
TIE, TOP, #336 KCM AAC BROWN	037800	UTC-1109	DTC-1495-P
TIE, TOP, #636 KCM ACSR/AAC BLUE	037900	UTC-1112	DTC-2175-P



### Conductor Repair Splice – Overhead

Originator: DSmith

Date: 7/7/06

Approval: DSmith

Date: 8/31/2007

Page 1 of 1

Revision: **NEW**

Stds Committee Approval:

**Approved**

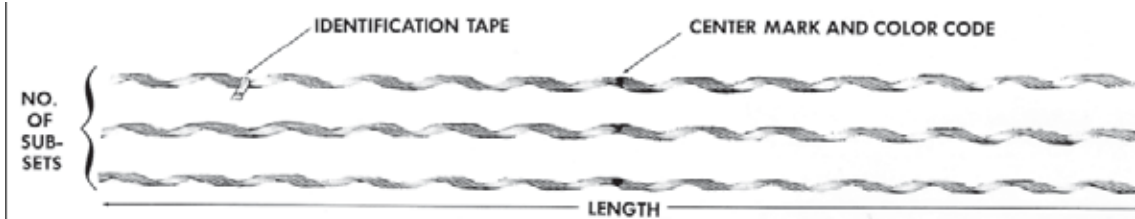

**Application:** Conductor Splices are designed as a single-component outer-layer assembly generally for Sub-EHV applications composed of three subsets.

On all-aluminum, aluminum alloy, and copper conductors of homogenous stranding, the Conductor Splice will hold a minimum of 90% of the rated breaking strength of, and provide better conductance than, an equal length of un-spliced conductor. On ACSR conductor, the *Conductor Splice* will hold a minimum tension amounting to the full strength of the aluminum strands plus 10% of the steel core strength. Conductance will be better than in an equivalent length of un-spliced conductor.

**Packaging and Marking:** Items shall be suitably packaged to prevent damage. The container shall be convenient for handling and storage. Manufacturer's name or symbol and catalog number shall be on each part or (and) its packaging.

#### Approved Manufacturers

PUD IDENTIFICATION		MFG NUMBER
Stock No.	Stock Description	Preformed Line Products
031390	SPLICE, OH REPAIR, #6ACSR 6/1, Three Rods, (BLUE)	LS-0108
031450	SPLICE, OH REPAIR, #2ACSR 6/1, Three Rods, (RED)	LS-0120
031250	SPLICE, OH REPAIR, #2/0AAC 7W, Three Rods, (BROWN)	LS-0127
031480	SPLICE, OH REPAIR, #2/0ACSR 6/1, Three Rods, (BLUE)	LS-0129
031270	SPLICE, OH REPAIR, #4/0AAC 7W, Three Rods, (BLACK)	LS-0133
031510	SPLICE, OH REPAIR, #4/0 ACSR 6/1, Three Rods, (RED)	LS-0134
031540	SPLICE, OH REPAIR, 266.8ACSR 26/7, Three Rods, (YELLOW)	LS-0137
031330	SPLICE, OH REPAIR, 336AAC 19W & 37W, Three Rods, (BROWN)	LS-0138
087530	SPLICE, OH REPAIR, 336ACSR 26/7, 397AAC 19W, Three Rods, (GREEN)	LS-0140
087520	SPLICE, OH REPAIR, 336ACSR 30/7, 397ACSR 18/1, 397 ACSR 36/1 Three Rods, (BLACK)	LS-0141
031550	SPLICE, OH REPAIR, 397ACSR 26/7, Three Rods, (PURPLE)	LS-0142
031560	SPLICE, OH REPAIR, 477ACSR 26/7, Three Rods, (ORANGE)	LS-0145
031360	SPLICE, OH REPAIR, 636 AAC 37W, Three Rods, (ORANGE)	LS-0146
031570	SPLICE, OH REPAIR, 636 ACSR 26/7, Three Rods, (YELLOW)	LS-0148



**PINS, INSULATOR**

Originator: DSmith

Date: 7/17/2006

Approval: DSmith

Date: 7/24/2007

Page 1 of 1

Revision: **NEW**

Stds Committee Approval:  
**Approved**

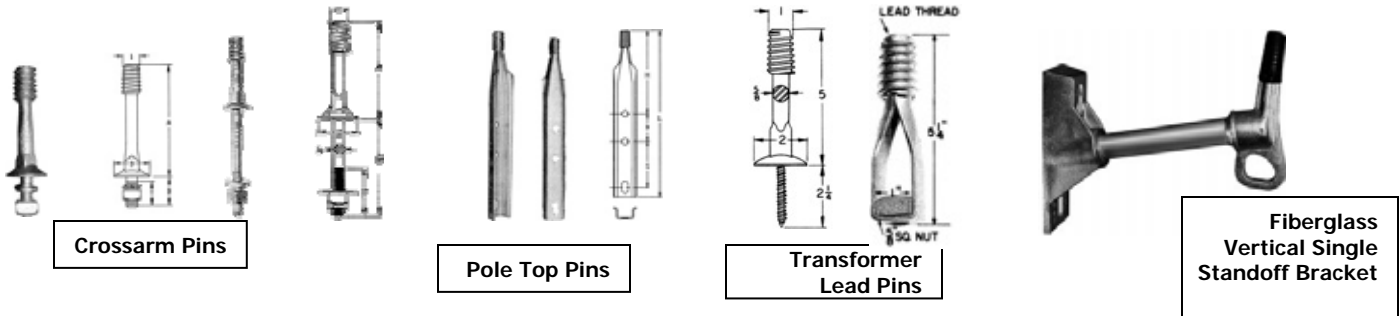

**Insulator Crossarm Pin Style:** Crossarms Pins are forged in one piece from alloy steel, hot dip galvanized, and supplied with 1" nylon thread for insulator mounting. They includes a square washer, square nut and curved lock nut.

**Pole Top Pins:** Pressed steel pole top pins with nylon alloy insulator threads are mounted against the pole by 5/8-inch bolts. The lower hole is slotted 11/16 x 1-1/4-inch on both two and three hole styles. Hot dip galvanized. The lower end of these pins is flattened and flared to give a solid bearing surface when mounted with the flange against the pole

**Transformer Lead Pins:** This pin is used for carrying the leads to the transformer. It has nylon alloy threads for insulators with ANSI standard 1-inch threaded pin holes. The Hot Dip Galvanized Body is a forging with a 1/2" diameter shank.

**Fiberglass Single Phase Vertical Standoff Brackets:** Fiberglass Standoff Brackets are manufactured from Fiberglass Reinforced Plastic (FRP) with ductile iron or aluminum alloy fittings. The plastic material is a Polyester or Vinylester matrix containing ultraviolet protective inhibitors. The insulator threads are 1" threads in accordance with ANSI C29.5 and are coated with a semi-conductive heat shrink material. All exposed fiberglass rod is coated with 2-3 mils of acrylic urethane enamel paint which is baked to hardness.

PUD IDENTIFICATION		Manufacture Part Numbers		
Stock Description	Stock No.	Hubbel	MacLean	Hughes
PIN, STL Pole Top 20" 13/24KV-1" THRD	025730	2174P	J1220Z	2770A20C5100
PIN, STL Pole Top 24" 35KV-1" THRD	025740	2197-1P	J744Z	2770A24C5100
PIN, XFMR LEAD	025595	888	J025Z	
PIN, STEEL, 1 1/2"-1 HD	025610		J221Z	
PIN, STEEL, 5/8" X 6 1/2" Shank with 1" Nylon Thread	025630	881AP	J204Z	2775A-6.5
PIN, STEEL, 5/8" X 8" Shank with 1" Nylon Thread	025650		J2802Z	
PIN, STEEL, 3/4" X 6 1/2" Shank with 1" Nylon Thread	025690		J607Z	
PIN, VERTICAL SINGLE STANDOFF BRACKET, FIBERGLASS	025750	Shakespeare 81020P	Continental #GBP56M20P	CF81021
PIN, STEEL ADAPTER EXTENSION FOR 15KV INSULATORS, Transformer Lead	025625	DP1A1	J2840	



**BRACKET, CUTOUT, POLE MOUNT**

Originator: DSmith

Date: 7/27/2006

Approval: DSmith

Date: 7/3/2007

Page 1 of 1

Revision: **NEW**

Stds Committee Approval:  
**Approved**

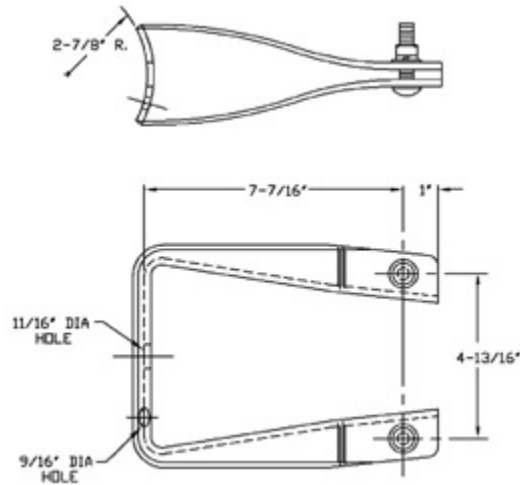

**Application:** Used to hang a 15kV cutout off a wooden pole. Made from Hot Dipped Galvanized Steel.

**Packaging and Marking:** Items shall be suitably packaged to prevent damage. The container shall be convenient for handling and storage. Manufacturer's name or symbol and catalog number shall be on each part or (and) its packaging.

**Shipping:** No Special Shipping Instructions

**Approved Manufacturers:**

PUD IDENTIFICATION		MANUFACTURER CATALOG NUMBER
Stock Description	Stock No.	Joslyn
BRACKET, CUTOUT, POLE MOUNT, 2-3/8" x 2" CARRAIGE BOLT ASSEMBLY	012580	J24518





**BRACKET, EXTENSION PLATE, DOUBLE  
ARMING**

Originator: DSmith

Date: 7/7/06

Approval: DSmith

Date: 7/7/06

Revision: **NEW**

Stds Committee Approval:  
**PENDING**

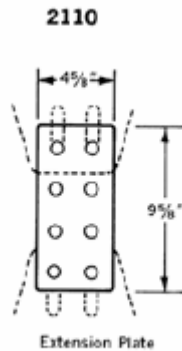

**Application:** State description and purpose of item, how it is used, any precaution associated with its use and any exceptional salvage instructions.

**Common Name:** Nickname or common name

**Ordering Description:** List requirements as needed to describe the properties of the item. If necessary, use blanks ( ) in description and add any of the following.

Dimensions:

Strength: Shall be capable of holding XXXX pounds

Material: The item shall be made of XXXX

Finish: The item shall be hot dipped galvanized

**Packaging and Marking:** Items shall be suitably packaged to prevent damage. The container shall be convenient for handling and storage. Manufacturer's name or symbol and catalog number shall be on each part or (and) its packaging.

**Shipping:** Special Shipping Instructions

**Approved Manufacturers:**

PUD IDENTIFICATION		MANUFACTURER CATALOG NUMBER
Stock Description	Stock No.	Linsley
BRACKET, PLATE, EXTENSION USED IN DOUBLE ARMING BRACKET	012780	2110





**BRACKET, TRANSFORMER, POLE MOUNT,  
DUAL/TRIPLE**

Originator: DSmith

Date: 7/3/2007

Approval: DSmith

Date: 7/9/2007

Page 1 of 1

Revision: **NEW**

Stds Committee Approval:

**Approved**

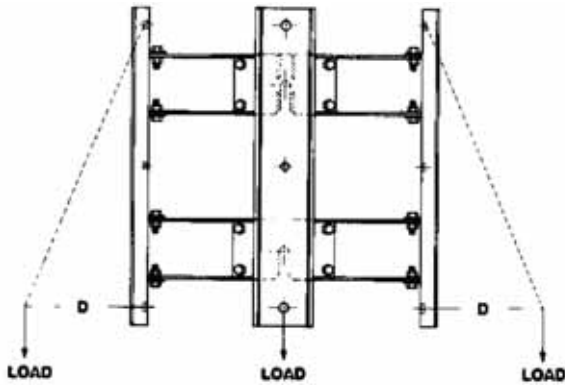

**WING-TYPE CLUSTER MOUNTS**

Model	Maximum Recommended Equipment Load (in pounds), <i>per Cluster Mount Phase</i> , for typical distance (in inches) from mounting pad face to equipment center of mass (C.O.G.):			
	14"	18"	22"	26"
3MW-24	625 lbs.	500 lbs.	410 lbs.	350 lbs.
3MW-24-M	1,250 lbs.	1,000 lbs.	820 lbs.	700 lbs.
11MW-24	2,500 lbs.	2,000 lbs.	1,640 lbs.	1,385 lbs.
12MW-24	2,500 lbs.	1,950 lbs.	1,600 lbs.	1,350 lbs.
12MW-30	2,000 lbs.	1,550 lbs.	1,275 lbs.	1,075 lbs.



**Application:** Used to mount two or three transformers on a single wood pole.

**Packaging and Marking:** Items shall be suitably packaged to prevent damage. The container shall be convenient for handling and storage. Manufacturer's name or symbol and catalog number shall be on each part or (and) its packaging.

**Shipping:** No Special Shipping Instructions

**Approved Manufacturers:**

PUD IDENTIFICATION			MANUFACTURER CATALOG NUMBER
Stock Description	Stock No.	(D) Max Lbs per position from mounting pad face to equipment center of mass	ALUMAFORM
BRACKET, XFMR, DUAL MOUNT, 3KVA-100KVA	012600	1,275 lbs @ 14"	DM-4M2
BRACKET, XFMR, TRIPLE MOUNT, 5KVA-50KVA	012620	1,000 lbs @ 18"	3MW-24-M-L
BRACKET, XFMR, TRIPLE MOUNT, 50KVA-250KVA	012640	2,000 lbs @ 18"	11MW-24-L



**BRACKET, STANDOFF  
1, 2, & 3 PHASE FIBERGLASS 15° TUBULAR ARM  
For 15kV Cutout & Arrestor**

Originator: DSmith

Date: 7/7/06

Approval: DSmith

Date: 7/27/2007

Page 1 of 1

Revision: **NEW**

Stds Committee Approval:  
**Approved**

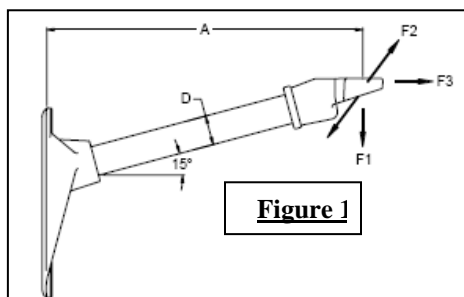

**Figure 1**

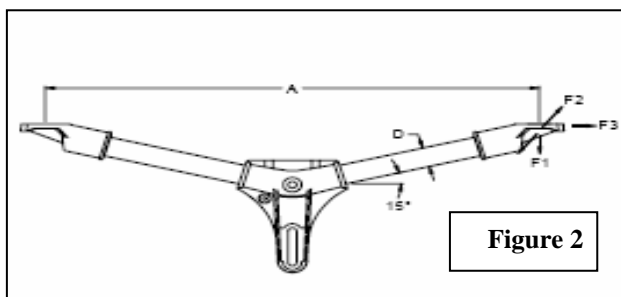

**Figure 2**

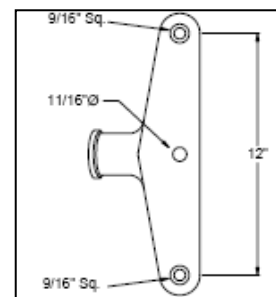

**Application:** This specification applies to pole mounted fiberglass standoff brackets for mounting a cable termination and surge arrester on a primary riser.

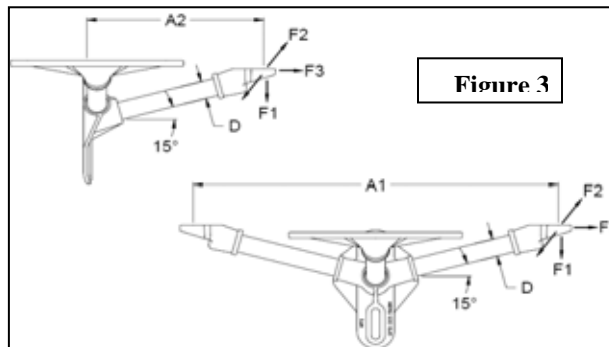
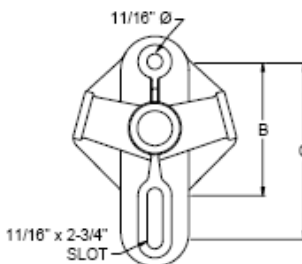

**Figure 3**

**PUD IDENTIFICATION**

**MANUFACTURER CATALOG NUMBER**

Stock Description	Stock No.	Fig	MANUFACTURER CATALOG NUMBER		
			HUGHES Brothers	MacLean	Hubbell
Bracket, Standoff For Cutout, Fiberglass, <b>1 Phase</b>	012650	1	CF892-24B	G1MDA124ADB	1SBM24AMTB
Bracket, Standoff For Cutout, Fiberglass, <b>2 Phase</b>	012680	2	CF550-48B	G2MAA148AB	2SBM48AMTB
Bracket, Standoff For Cutout, Fiberglass, <b>3 Phase</b>	012690	3	NA	G3MAA14824ADB	3SBM4824AMTB

Description	Stock No.	Rod Dia	Dimensions (in.)		Bolt Spacing (in.)		Minimum Ultimate Strength - Lbs		
			A1/A	A2	B	C	F1 Vertical	F2 Long.	F3 Transverse
1 Phase	012650	1-1/2"	24		6	8	900	700	10,000
2 Phase	012680	1-1/2"	48		6	8	900	700	10,000
3 Phase	012690	1-1/2"	48	24	6	8	900	700	10,000

The standoff bracket shall consist of a no removable base and end fittings permanently secured to a fiberglass rod. Base and end fittings shall be manufactured from cast aluminum alloy or hot-dip galvanized malleable iron. Fiberglass rod shall have a weather and ultraviolet resistant coating and shall be Munsell gray in color. Galvanized or stainless steel 1/2" X 2" carriage bolts, hex nut and lock washer shall be supplied for each equipment mounting hole.

**Packaging and Marking:** Items shall be suitably packaged to prevent damage. The container shall be convenient for handling and storage. Manufacturer's name or symbol and catalog number shall be on each part or (and) its packaging.



**TURNBUCKLE**

Originator: Jeff Flader

Date: 3/18/2013

Approval: Jeff Flader

Date: 3/18/2013



Product Image

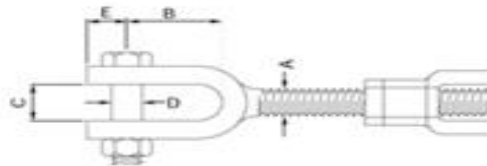

**Application:** Used in braced post insulator assemblies for transmission.

**Common Name:** Turnbuckle

**Ordering Description:** Ultimate Strength 26,000 lbs plus, Length 15 1/2" to 22 1/2".  
 Jaw width = minimum of 3/4", Jaw to Jaw connectors.

**Packaging and Marking:** Items shall be suitably packaged to prevent damage. The container shall be convenient for handling and storage. Manufacturer's name or symbol and catalog number shall be on each part or (and) its packaging.

**Approved Manufacturers:**

PUD IDENTIFICATION		MANUFACTURER CATALOG NUMBER		
Stock Description	Stock No.	Hughes	Hubbell	MacLean
Turnbuckle, 26,000 Lbs, Length 15 1/2" To 22 1/2". Jaw Width = Minimum Of 3/4". Jaw To Jaw Connectors.	085899	AS2545Z	TB-3/4-JJ-6	G-228-3/4x6



DEADEND, CLEVIS, Y BALL - HOTLINE

Originator: Jeff Flader

Date: 1/25/2012

Approval: Jeff Mitchell

Date: 1/25/2012

Revision: **NEW**

Stds Committee Approval:  
**Pending**

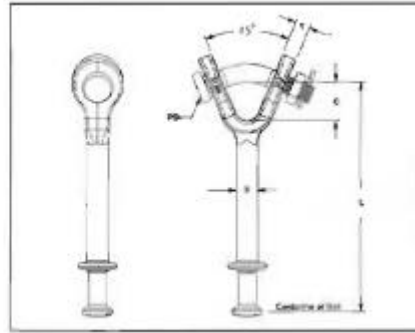

**Application:** Installed between transmission conductor dead ends and 115 kv insulators

**Common Name:** Deadend, Clevis, Y Ball - Hotline

**Ordering Description:** Deadend, Clevis, Y Ball, Hotline, Hd Galv, 9" To 10" Long, 3/4" Pin, 30,000 Lb Rating.

**Packaging and Marking:** Items shall be suitably packaged to prevent damage. The container shall be convenient for handling and storage. Manufacturer's name or symbol and catalog number shall be on each part or (and) its packaging.

**Approved Manufacturers:**

PUD IDENTIFICATION		MANUFACTURER CATALOG NUMBER			
Stock Description	Stock No.	Hubbell	Anderson	Preformed	Maclean
DEADEND, CLEVIS, Y BALL - HOTLINE	085700	HYBC-30	HYBC-30	BYCL-30	YCBHL-65A



**DEADEND, CLEVIS, Y BALL**

Originator: Jeff Flader

Date: 1/25/2012

Approval: Jeff Mitchell

Date: 1/25/2012

Page 1 of 1

Revision: **NEW**

Stds Committee Approval:  
**Pending**

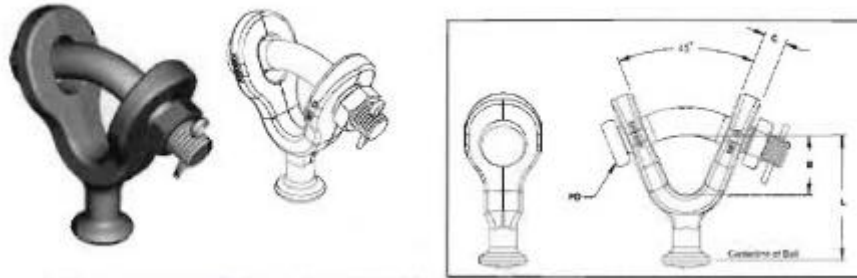

**Application:** Used to secure conductor suspension cushion grips to side stack insulators.

**Common Name:** Deadend, Clevis, Y Ball

**Ordering Description:** Deadend, Clevis, Y Ball, Hot Dipped Galv, 3" To 4" Long, 3/4" Pin, 30,000 Lb Rating.

**Packaging and Marking:** Items shall be suitably packaged to prevent damage. The container shall be convenient for handling and storage. Manufacturer's name or symbol and catalog number shall be on each part or (and) its packaging.

**Approved Manufacturers:**

PUD IDENTIFICATION		MANUFACTURER CATALOG NUMBER			
Stock Description	Stock No.	Hubbell	Anderson	Preformed	Maclean
Deadend, Clevis, Y Ball	015150	YBC-30	YBC-30	BYC-30	YCB-65A



**POST CLAMP ADAPTERS,  
VERTICAL/HORIZONTAL**

Originator: DSmith

Date: 7/7/06

Approval: DSmith

Date: 7/3/2007

Page 1 of 1

Revision: **NEW**

Stds Committee Approval:  
**Approved**

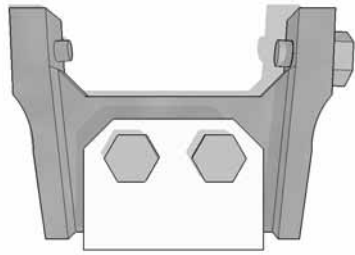

**Horizontal Post Clamp Adapter**

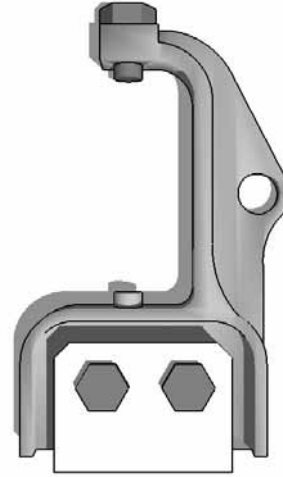

**Vertical Post Clamp Adapter**

**Application:** Used to support wire saddle on horizontal post transmission insulators that only have NEMA two hole connector.

**Packaging and Marking:** Items shall be suitably packaged to prevent damage. The container shall be convenient for handling and storage. Manufacturer's name or symbol and catalog number shall be on each part or (and) its packaging.

**Approved Manufacturers:**

PUD IDENTIFICATION		MANUFACTURER CATALOG NUMBER
Stock Description	Stock No.	HUBBELL
ADAPTER, VERTICAL LINE, POST CLAMP, FOR 3-1/2" WIDE WIRE CLAMP (SUSP TYPE)	021835	271615-3001
ADAPTER, HORIZ. LINE, POST CLAMP W/ RIGGING EYE, FOR 4" WIDE WIRE CLAMP (SUSP TYPE)	021840	271630-3001



**LINE HARDWARE, YOKE, SUSPENSION**

Originator: DSmith

Date: 7/31/2006

Approval: DSmith

Date: 7/3/2007

Revision: **NEW**

Stds Committee Approval:  
**Approved**

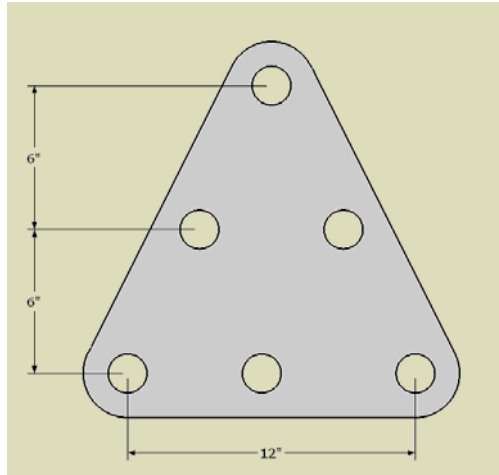

**Application:** These yoke plates are used to bundle two conductors with a single and VEE string of insulators and maintain the proper running angle of the line. Yoke plates may be furnished in a variety of sizes, hole spacing, ultimate strengths and insulator attachment angles.

Material: Ductile iron, galvanized or steel, galvanized.

**Packaging and Marking:** Items shall be suitably packaged to prevent damage. The container shall be convenient for handling and storage. Manufacturer's name or symbol and catalog number shall be on each part or (and) its packaging.

**Approved Manufacturers:**

PUD IDENTIFICATION		MANUFACTURER CATALOG NUMBER
Stock Description	Stock No.	
YOKE, PLATE, DBL ARM, 6"x6"x12", TRIANGULAR, 13/16" BOLT HOLES	086700	HUGHES BROTHERS: AS-2355-G
YOKE ASSEMBLY, HD GALV, 18"x1/2"	088800	OHIO BRASS: 88693





**DEADEND, CLEVIS, Y- EYE**

Originator: Jeff Flader

Date: 3/6/2012

Approval: Jeff Mitchell

Date: 3/6/12

Revision: **NEW**

Stds Committee Approval:  
**Pending**



**Application:** used in dead end assemblies to connect down guys to vangs or pole eye plates.

**Common Name:** Deadend, Clevis, Y- Eye

**Ordering Description:** Deadend, Clevis, Y- Eye, Ductile Iron, Hd Galv, 13/16" Hole at Eye, with 3/4" pin, 25,000 Lb ultimate strength

**Packaging and Marking:** Items shall be suitably packaged to prevent damage. The container shall be convenient for handling and storage. Manufacturer's name or symbol and catalog number shall be on each part or (and) its packaging.

**Approved Manufacturers:**

PUD IDENTIFICATION		MANUFACTURER CATALOG NUMBER	
Stock Description	Stock No.	MACLEAN	PREFORMED
Deadend, Clevis, Y- Eye, Ductile Iron, Hd Galv, 13/16" hole at Eye, with 3/4" Pin, 25,000 Lb ultimate strength	015110	YCE-66-750	YC-5211



**Deadend, Compression, Vertical Eye Type,  
Single Tongue, ACSR Conductors**

Originator: Jennifer Smith

Date: 10/17/2008

Approval: Jennifer Smith

Date: 10/17/2008

Page 1 of 1

Revision: **NEW**

Stds Committee Approval:  
**Approved**

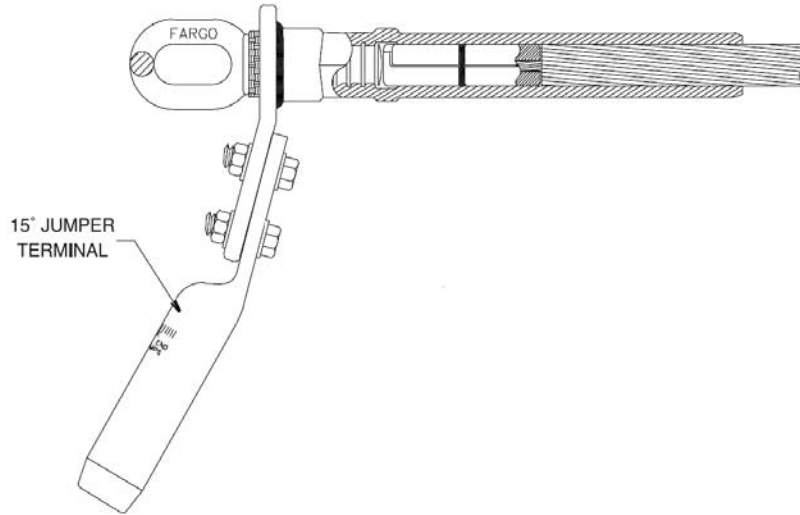

**Application:** A deadend assembly for Aluminum Conductor Steel Reinforced (ACSR) conductors consists of a pre-filled aluminum deadend body precompressed onto a steel eye, a prefilled 15° jumper terminal, mounting hardware and core gripping unit. Terminal and tongue have NEMA hole spacing.

**Common Name:** Deadend Bodies

**Approved Manufacturers:** Anderson, Alcoa

PUD IDENTIFICATION		MANUFACTURER CATALOG NUMBER	
Stock Description	Stock No.	Alcoa	Anderson
Deadend, Compression, Vertical Eye Type, Single Tongue, 336 ACSR 26/7, "Linnet"	030303	VES086	A0108131
Deadend, Compression, Vertical Eye Type, Single Tongue, 397 ACSR 26/7, "Ibis"	030304	VES096	
Deadend, Compression, Vertical Eye Type, Single Tongue, 477 ACSR 26/7, "Hawk"	030305	VES105	A0110211
Deadend, Compression, Vertical Eye Type, Single Tongue, 636 ACSR 26/7, "Grosbeak"	030306	VES116	
Deadend, Compression, Vertical Eye Type, Single Tongue, 795 ACSR 26/7, "Drake"	030307	VES126	A0112451
Deadend, Compression, Vertical Eye Type, Single Tongue, 1272 ACSR 45/7, "Bittern"	030308	VES153	A0115591
Deadend, Compression, Vertical Eye Type, Single Tongue, 1780 ACSR 84/19, "Chukar"	030309	VES174	



**Deadends, Compression, Vertical Eye Type,  
Double Tongue, ACSR Conductors**

Originator: Jennifer Smith

Date: 10/17/2008

Approval: Jennifer Smith

Date: 10/17/2008

Page 1 of 1

Revision: **NEW**

Stds Committee Approval:  
**Approved**

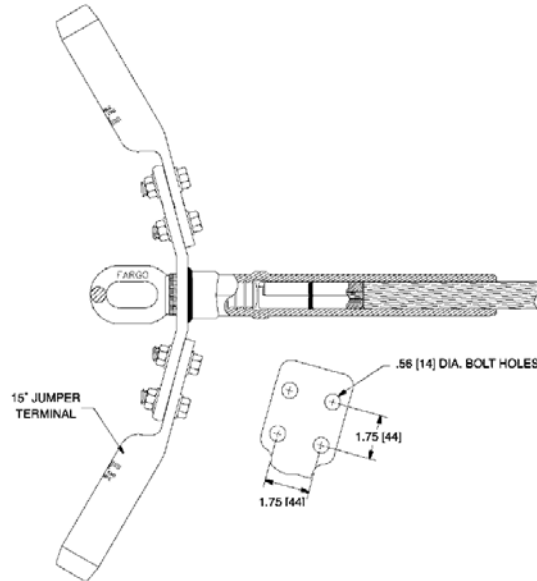

**Application:** A deadend assembly for Aluminum Conductor Steel Reinforced (ACSR) conductors consists of a pre-filled aluminum deadend body precompressed onto a steel eye, two prefilled 15° jumper terminals, mounting hardware and core gripping unit. Terminal and tongue have NEMA hole spacing.

**Common Name:** Deadend Bodies

**Approved Manufacturers:** Alcoa

PUD IDENTIFICATION		MANUFACTURER CATALOG NUMBER	
Stock Description	Stock No.	Alcoa	
Deadend, Compression, Vertical Eye Type, Double Tongue, 336 ACSR 26/7, "Linnet"	030283	VED086	
Deadend, Compression, Vertical Eye Type, Double Tongue, 636 ACSR 26/7, "Grosbeak"	030284	VED116	



# ANCHOR SHACKLE

Originator: DSmith

Date: 7/7/2006

Approval: J Mitchell

Date: 5/13/2011

Page 1 of 1

Revision: **Catalog #'s**

Stds Committee Approval:  
**Approved**

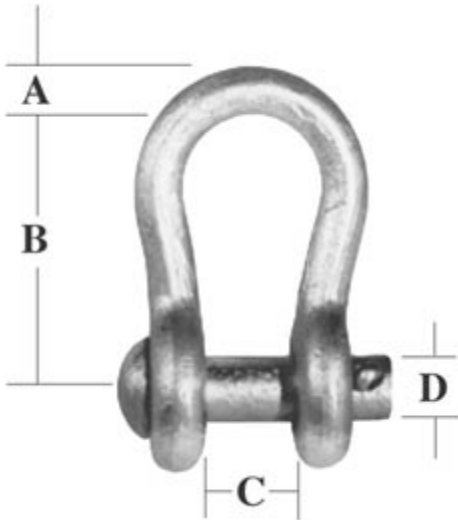

### Application

The anchor shackle is generally used as part of the insulator attachment hardware on electric transmission lines. Anchor Shackles are used for attaching suspension insulators to towers, yokes, and double arming plates. Openings are enlarged to permit the use of two or more fittings.

### Specifications:

**Material:** Shackle, bolt and nut shall be heat treated steel per latest revisions of ASTM A36, A354 and A563 or better. Cotter pin shall be stainless steel.

**Weight of Coating:** All hardware shall be hot dip galvanized per latest revision of ASTM A153 Class A.

### Packaging & Marking

Items shall be suitably packaged to prevent damage. The container shall be convenient for handling and storage. Manufacturer's name or symbol and catalog number shall be on each part and its packaging.

### Approved Manufacturers

PUD IDENTIFICATION Stock Description	MANUFACTURER CATALOG NUMBER			
	Stock No.	Joslyn	Hubbell	Maclean
Shackle 1/2" Body with 5/8" Pin	028580	J2742	5801	
Shackle 5/8" Body with 5/8" Pin	028590			ASH-55
Shackle 5/8" Body with 3/4" Pin	028600		AS35-BNK	ASH-56
Shackle 3/4" Body with 3/4" Pin	028610		AS-50	ASH-66A



### Slack Span Dead End Twisted-Grip

Originator: DSmith

Date: 7/10/2006

Approval: DSmith

Date: 7/9/2007

Page 1 of 1

Revision: **NEW**

Stds Committee Approval:  
**Approved**



**Application:** The slack span dead end is intended for use where guying restrictions prevent full tension spans. This type of dead end is RFI free and is more economical than the DE clamp/insulator combination. Do not use automatic deadends on slack spans. For use on ACSR, AAAC, and AAC.

**Specification:** Helical Leg Section: Coated steel, right-hand lay. Covered Loop Section: Elastomeric compound shall resist ozone attack, weathering and abrasion.

**Packaging and Marking:** Items shall be suitably packaged to prevent damage. The container shall be convenient for handling and storage. Manufacturer's name or symbol and catalog number shall be on each part or (and) its packaging.

**Approved Manufacturers:**

PUD IDENTIFICATION Stock Description	Stock No.	MANUFACTURER CATALOG #	
		Preformed	TYCO
GRIP SLK SPAN, C&F #2 ACSR, RED	016200	SSDE-9124	SSDE-0735
GRIP SLK SPAN, C&F #2/0 ACSR, BLUE	016205	SSDE-9127	SSDE-1040
GRIP SLK SPAN, C&F #4/0 ACSR, RED	016210	SSDE-9129	
GRIP SLK SPAN, C&F 336.4KCMIL ACSR, Green	016215	SSDE-9131	
GRIP SLK SPAN, C&F 636KCM ACSR, Brown	016212	SSDE-9133	

**Salvage Instructions**

Do not salvage; do not reuse after initial installation.



**DEADENDS  
AUTOMATIC FEED THRU**

Originator: DSmith

Date: 12/5/06

Approval: DSmith

Date: 12/5/06

Page 1 of 2

Revision: **NEW**

Stds Committee Approval:  
**Approved**

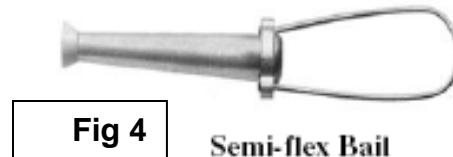
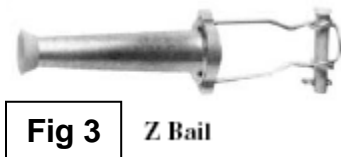

**Approved Manufacturers:**

PUD IDENTIFICATION		MANUFACTURER CATALOG NUMBER		
Stock Description	Fig #	Stock No.	Hubbell	MaClean
DEADEND, AUTO, CLEVIS BAIL, 12M Guy	1	016300		5202LD
DEADEND, AUTO, CLEVIS BAIL, #4 AAC/ACSR	1	016350	GD442A	7651LDE
DEADEND, FEED THRU, AUTOMATIC W/CLEVIS BAIL AND PULLING EYE, #2 - #4 ACSR, AL, AAAC - COLOR CODED RED-ORANGE	1	016375	GD4442A-TA	7652APLDE
DEADEND, AUTO, CLEVIS BAIL AND PULLING EYE, #2/0 ACSR/AAC/AAAC, COLOR CODED GRAY	1	016400	GD447-TA	7654APLDE
DEADEND, AUTO, CLEVIS BAIL AND PULLING EYE, #4/0 ACSR/AAC/AAAC, COLOR CODED PINK	1	016410	GD449A-TA	7656APLDE
DEADEND, AUTO, CLEVIS BAIL, #2/0 SOL CU, 1/0 STR, #2A CWELD	1	016610	GD517	107-LD
DEADEND, AUTO, FLEX BAIL, #4 AAC/ACSR - ORANGE	2	016360	GD402A	
DEADEND, AUTO, SS FLEX BAIL, #2 - #4 AAC/ACSR - COLOR CODED RED-ORANGE	2	016370	GD4042A	7652AP-FD
DEADEND, AUTO, SS FLEX BAIL, #2/0 AAC/ACSR/AAAC, COLOR CODED GRAY	2	016390	GD407	7654AP-FD
DEADEND, AUTO, FLEX BAIL, #4 STR CU, #6A CW	2	016525	GD113	47-FD
DEADEND, AUTO, FLEX BAIL, #6 SOL CU	2	016550	GD111	61-FD
DEADEND, AUTO, FLEX BAIL, #4 SOL CU, #8A CWELD	2	016570	GD112	41-FD
DEADEND, AUTO, FLEX BAIL, #2 SOL CU, #3 STR, #5A CWELD	2	016590	GD114	21-FD
DEADEND, AUTO, Z BAIL, #6A CW, #4 STR CU	3	016530	GD113Z	21-SDS
DEADEND, AUTO, Z BAIL, #6 SOL CU	3	016560	GD111Z	61-SDS
DEADEND, AUTO, Z BAIL, #4 SOL CU	3	016580	GD112Z	41-SDS
DEADEND, AUTO, Z BAIL, #2 SOL CU, #3 STR CU	3	016595	GD114Z	21-SDS



**DEADENDS  
AUTOMATIC FEED THRU**

Originator: DSmith

Date: 12/5/06

Approval: DSmith

Date: 12/5/06

Page 2 of 2

Revision: **NEW**

Stds Committee Approval:  
**Approved**

**Application:** Fastest method of deadending ACSR, AAAC, and AAC conductor

**Specification:**

Material: Shell – High Strength Aluminum Alloy or copper

Jaws – Aluminum Alloy or Brass

Clevis Bail – Aluminum Alloy or Galvanized Steel

Z Bail – Stainless Steel, formed wire

Flex Bail – Braided stainless steel

Semi-flex Bail – Stainless Steel, formed wire

Pulling Eye – Aluminum Alloy

Strength: The grips shall be capable of holding at least 95% of the rated conductor ultimate strength. The flexible bail shall be detachable. The clamp shall contain protective inhibitor.

All clevis pins are 0.62” in diameter.

**Packaging and Marking:** Items shall be suitably packaged to prevent damage. The container shall be convenient for handling and storage. Manufacturer’s name or symbol and catalog number shall be on each part or (and) its packaging.





**SOCKET EYE  
TRANSMISSION**

Originator: DSmith

Date: 11/29/2011

Approval: J Flader

Date: 12/1/2011

Page 1 of 1

Revision: **NEW**

Stds Committee Approval:  
**APPROVED**



**Application:** Socket eyes can be used for connecting transmission conductor clamping devices to ball and socket type insulators.

**Specifications:**

Material: Body—ductile iron, galvanized  
Cotter Pin—stainless steel

**Packaging and Marking:** Items shall be suitably packaged to prevent damage. The container shall be convenient for handling and storage. Manufacturer's name or symbol and catalog number shall be on each part or (and) its packaging.

**Approved Manufacturers:**

PUD IDENTIFICATION		MANUFACTURER CATALOG NUMBER		
Stock Description	Stock No.	MacLean	Hubbell	Preformed
SOCKET EYE, DUCTILE IRON, GALV, 3/4" THICK WITH 13/16" HOLE, STRENGTH RATING 25000 LB.	017380	<b>SE-1250-6</b>	<b>SA-11</b>	<b>SE-5154</b>
SOCKET EYE, DUCTILE IRON, GALV, 1/2" THICK WITH 11/16" HOLE	017390	<b>SI-500</b>	<b>SA-04</b>	



**HOOK, SHORT/LONG SHANK, SELF LOCKING**

Originator: DSmith

Date: 7/7/2006

Approval: DSmith

Date: 7/10/2007

Page 1 of 1

Revision: **NEW**

Stds Committee Approval:  
**APPROVED**

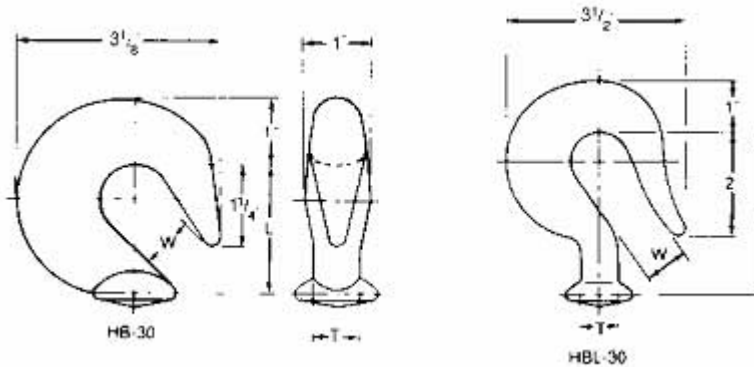

**Application:** Hooks are used to attach ball and socket or clevis insulators directly to the tower attachment pad. All hooks are of the self-locking design.

Catalog Number	Ultimate Strength Lbs (kg)	Dimensions Inches (mm)			Approx Wt Each Lbs (kg)
		L	W	T	
HB-30	30,000 (13,608)	2 (50.80)	13/16 (20.64)	23.32 (18.26)	1.05 (.48)
HBL-30	30,000 (13,608)	3-1/8 (79.38)	7/8 (22.23)	23.32 (18.26)	1.33 (.60)

**Approved Manufacturers:**

PUD IDENTIFICATION		MANUFACTURER CATALOG NUMBER
Stock Description	Stock No	Hubbell
Hook, Short Shank	020790	HB-30
Hook, Long Shank	020810	HBL-30



**CLEVIS, SOCKET, HOTLINE**

Originator: Flader, Jeff

Date: 1/25/2012

Approval: Flader, Jeff

Date: 1/25/2012

Page 1 of 1

Revision: **NEW**

Stds Committee Approval:  
**Pending**



**Application:** used at dead end assemblies to secure transmission conductor.

**Common Name:** Clevis, Socket, Hotline

**Ordering Description:** Clevis, Socket, Hotline, Hd Galv, 10", Clevis Width 1" With 5/8" Pin & Cotter Key, 30k Lb Ultimate Strength.

**Packaging and Marking:** Items shall be suitably packaged to prevent damage. The container shall be convenient for handling and storage. Manufacturer's name or symbol and catalog number shall be on each part or (and) its packaging.

**Approved Manufacturers:**

PUD IDENTIFICATION		MANUFACTURER CATALOG NUMBER		
Stock Description	Stock No.	Hubbell	Anderson	Maclean
Clevis, Socket, Hotline, Hd Galv, 10"	085500	HSC-100	HSC-100	HCHL-55A



# POLE ANCHOR, TRI-ANCHOR

Originator: DSmith

Date: 7/7/06

Approval: DSmith

Date: 6/8/2009

Page 1 of 2

Revision: **Added Installation Instructions**

Stds Committee Approval:  
**Approved**

**Application:** This device is used to support a utility pole when no hole can be dug to a sufficient depth due to rock. The unit must be mounted into solid rock.

**Specification:** INCLINED UNIVERSAL NO.9 TRI-ANCHOR® modules are shipped assembled, each consisting of a forged anchor bolt, expansion shell, welded pipe and band assembly, washer and nut; along with the required field assembly hardware (2 studs c/w 2 nuts each, and 4 lag bolts) included in a separate canvas bag. Each pole installation requires 3, 4, or 5 anchor modules, depending on the pole butt diameter

**Packaging and Marking:** Items shall be suitably packaged to prevent damage. The container shall be convenient for handling and storage. Manufacturer's name or symbol and catalog number shall be on each part or (and) its packaging.



### Approved Manufacturers:

PUD IDENTIFICATION			MANUFACTURER CATALOG NUMBER
Stock Description	Stock No.		TRI-ANCHOR
ANCHOR, POLE, TRI-ANCHOR, (1) LEG + ACCESSORIES	027350		P-9UT

See STD Practice 062.ROCKANCHOR for engineering/installation information and requirements (# of legs required, grd line moment, etc.).

### INSTALLATION INSTRUCTIONS

- REMOVE OVERBURDEN:** The pole butt must rest directly on the rock, so all loose overburden of soil, gravel, etc. must be removed.
- EVALUATE ROCK:** If the rock is fractured or unsound, an alternative method to the INCLINED UNIVERSAL NO.9 TRI-ANCHOR® should be used. e.g. if the rock can be easily broken, shoveled or augered, this would suggest insufficient rock soundness.
- CHECK SLOPE:** The maximum allowable slope in the rock under the pole for an INCLINED UNIVERSAL NO.9 TRI-ANCHOR® installation is 3 inches, over the diameter of the pole butt. i.e. there must not be a gap of more than 3 inches between the pole butt and the rock, and the pole must rest on the rock at some point.



**POLE ANCHOR, TRI-ANCHOR**

Originator: DSmith

Date: 7/7/06

Approval: DSmith

Date: 6/8/2009

Page 2 of 2

Revision: **Added Installation Instructions**

Stds Committee Approval:  
**Approved**

- 4. DECIDE ON NUMBER OF MODULES: Consult the Selection Chart to decide on the required number of modules for the installation, which varies with the pole butt diameter. Where the ranges overlap, the required ground line moments will help determine the number of modules to be used.
- 5. ASSEMBLE ROCK DRILLING TEMPLATE: Choose the appropriate template core for the configuration chosen (i.e. 3, 4 or 5 modules). Insert the sleeves into the template core.
- 6. ADJUST TEMPLATE: Fit the assembled template to the pole butt, adjusting it for the pole size. Place the template right side up on the rock so that the holes to be drilled point **OUTWARD** from the pole center. The proper slope is given by the inclined drilling sleeve. On sloped rock, use the leveling bolts to ensure that the template is level before drilling.
- 7. DRILL HOLES: Begin at the highest point of the rock and drill a 2" diameter hole through the template to a depth of 24 inches. Continue drilling the remaining holes through the template to the same depth, when measured from a horizontal line. All rock dust should be cleaned out.
- 8. INSERT THE ANCHORS: With all holes drilled, remove the template and drop the anchors into the holes. Loosely connect the bands with the studs.
- 9. ERECT POLE AND TIGHTEN BANDS: Lift and hold the pole in place vertically. Tighten all the studs to grip the pole within the bands. Ensure that all nuts are firmly tightened.
- 10. TIGHTEN ANCHOR BOLTS: Tighten the nuts of the anchor bolts firmly. In sound rock a positive anchor will develop from the expansion of the expansion shell. In poor rock you will run out of thread before developing an adequate bond, and an alternate location or method must be used.
- 11. INSTALL LAG BOLTS: Install all lag bolts with a wrench. Pre-drilling holes in the pole and using an impact wrench or socket wrench are recommended. Release the pole.
- 12. FINAL STEPS: Grouting of the holes is optional if ice is a concern. Backfill any removed overburden if desired.
- 13. MAINTENANCE: Incorporate the **INCLINED UNIVERSAL NO.9 TRI-ANCHOR®** system into the regular pole and line maintenance schedule and procedures. At each inspection ensure that all nuts and lags are in place and tight.

Manufacture Contact Information:  
 TRI-STEEL USA  
 1535 CABOT ST. # 201  
 MONTREAL, CANADA H4E 1C8  
 TOLL FREE: 1-888-ON-ROCK-8  
 1-888-667-6258  
 Fax: 514-766-6111  
 E-MAIL: info@tri-anchor.com



**THIMBLE, GUY WIRE**

Originator: DSmith

Date: 7/28/2006

Approval: DSmith

Date: 7/3/2007

Page 1 of 1

Revision: **NEW**

Stds Committee Approval:  
**Approved**

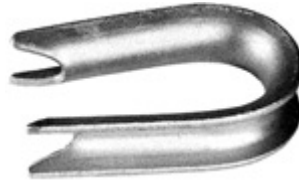

**Application:** Guy Wire Thimbles for wire rope strand size. Open end slips over ovaley anchor rods and bolts. Grooved to fit various strand sizes, they are made from crescent-shaped stock to prevent abrupt, strand-weakening kinks. Hot dip galvanized steel.

**Packaging and Marking:** Items shall be suitably packaged to prevent damage. The container shall be convenient for handling and storage. Manufacturer's name or symbol and catalog number shall be on each part or (and) its packaging.

**Approved Manufacturers:**

PUD IDENTIFICATION		MANUFACTURER CATALOG NUMBER
Stock Description	Stock No.	Hubbell
THIMBLE, OPEN WIRE ROPE, GROOVE: 1/2" OPEN WIDTH: 3/4" EYE WIDTH: 1-1/8"	033300	6594



**Deadends, Compression, Vertical Eye Type,  
Single Tongue, AAC Conductors**

Originator: Jennifer Smith

Date: 10/17/2008

Approval: Jennifer Smith

Date: 10/17/2008

Page 1 of 1

Revision: **NEW**

Stds Committee Approval:  
**Approved**

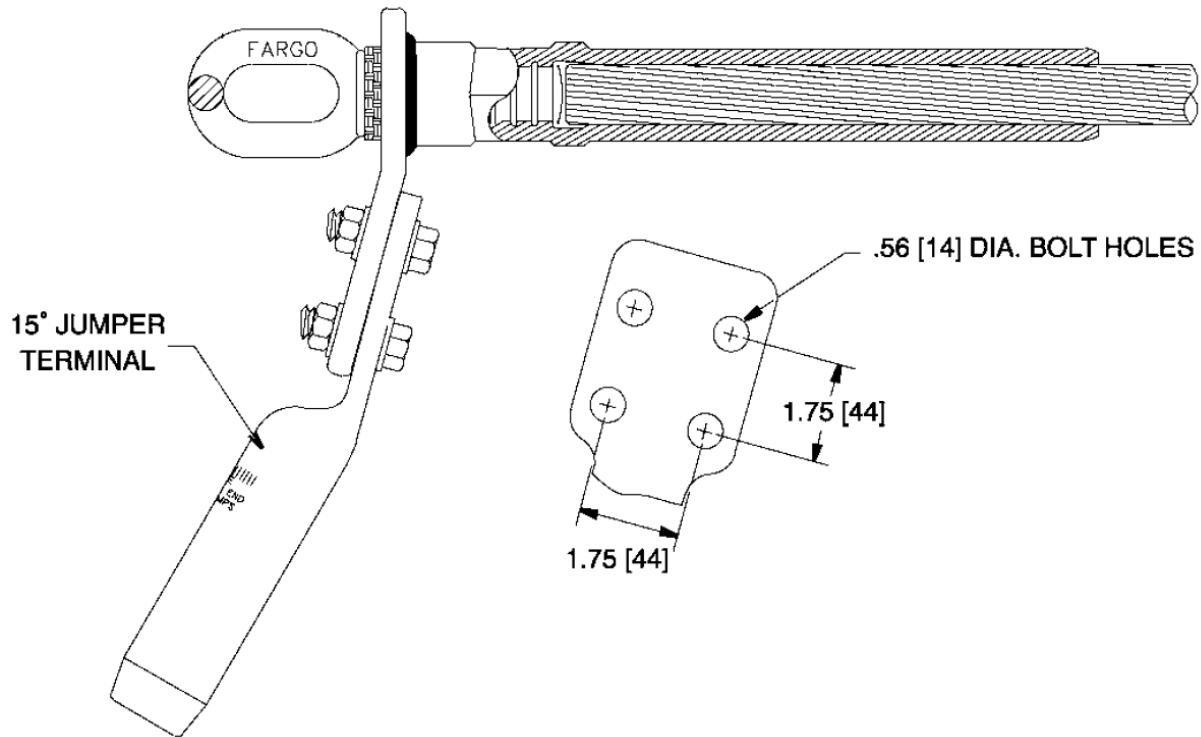

**Application:** A deadend assembly for All Aluminum (AAC) conductors consists of a pre-filled aluminum deadend body precompressed onto a steel eye, a prefilled 15° jumper terminal, mounting hardware. Terminal and tongue have NEMA hole spacing.

**Common Name:** Deadend Bodies

**Approved Manufacturers:** Anderson, Alcoa

PUD IDENTIFICATION		MANUFACTURER CATALOG NUMBER	
Stock Description	Stock No.	Alcoa	Anderson
Deadend, Compression, Vertical Eye Type, Single Tongue, 336 AAC 19 Strand, "Tulip"	030300	VESE070	C010707
Deadend, Compression, Vertical Eye Type, Single Tongue, 636 AAC 37 Strand, "Orchid"	030301	VESE100	C011010
Deadend, Compression, Vertical Eye Type, Single Tongue, 954 AAC 37 Strand, "Magnolia"	030302	VESE120	C011212





**Deadends, Compression, Vertical Eye Type,  
Double Tongue, AAC Conductors**

Originator: Jennifer Smith

Date: 10/17/2008

Approval: Jennifer Smith

Date: 10/17/2008

Revision: **NEW**

Stds Committee Approval:  
**Approved**

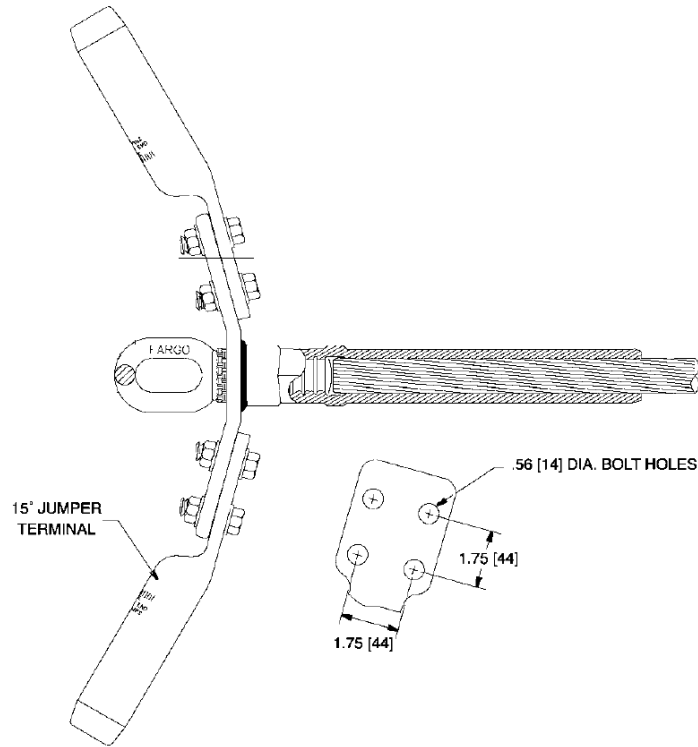

**Application:** A deadend assembly for All Aluminum (AAC) conductors consists of a pre-filled aluminum deadend body precompressed onto a steel eye, two prefilled 15° jumper terminals, mounting hardware. Terminal and tongue have NEMA hole spacing.

**Common Name:** Deadend Bodies

**Approved Manufacturers:** Anderson, Alcoa

PUD IDENTIFICATION		MANUFACTURER CATALOG NUMBER	
Stock Description	Stock No.	Alcoa	Anderson
Deadend, Compression, Vertical Eye Type, Double Tongue, 336 AAC 19 Strand, "Tulip"	030280	VEDE070	C020707
Deadend, Compression, Vertical Eye Type, Double Tongue, 636 AAC 37 Strand, "Orchid"	030281	VEDE100	C021010
Deadend, Compression, Vertical Eye Type, Double Tongue, 954 AAC 37 Strand, "Magnolia"	030282	VEDE120	C021212



**LINK, RIGGING**

Originator: Flader, Jeff

Date: 3/22/2012

Approval:

Date: 3/22/2012

Revision: **NEW**

Stds Committee Approval: **Approved**

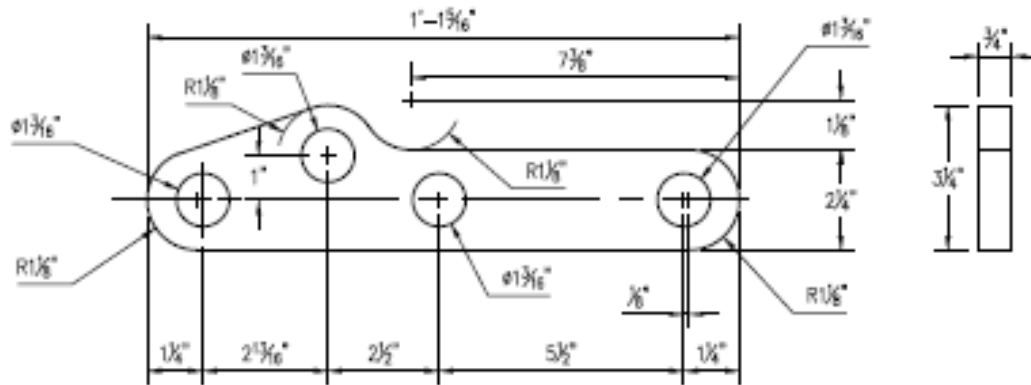

TEMPLATE #103  
A2195.6A LINK

**Application:** Used At 115 Kv Dead Ends Between Pole Eye Plates and Insulators.

**Common Name:** Rigging Link

**Ordering Description:**

Dimensions: 13 5/16", Widt 2 1/4", Thickness 3/4", Holes 1 3/16"

Material: Hd Galv – 30,000 Lb Ultimate Strength

**Approved Manufacturers:**

PUD IDENTIFICATION		MANUFACTURER CATALOG NUMBER
Stock Description	Stock No.	MFG #1
Link, Rigging, Hd Galv, 13 5/16", Width 2 1/4", Thickness 3/4", Holes 1 3/16"	086530	<b>*SPECIAL ORDER HUGHES BROS.</b>



**SOCKET, CLEVIS - SHORT**

Originator: Jeff Flader

Date: 3/22/2012

Approval: Jeff Mitchell

Date: 3/22/12

Page 1 of 1

Revision: **NEW**

Stds Committee Approval: **Approved**



**Application:** Used in dead end assemblies to connect polymer insulators to vertical eye compression dead ends.

**Common Name:** Clevis, Socket, Short

**Ordering Description:** Clevis, Socket, Short, 5/8" Pin, 2 5/8" From Socket To Pin, Ductile Iron, Hd Galv, 30,000 Lb Ultimate Strength.

**Packaging and Marking:** Items shall be suitably packaged to prevent damage. The container shall be convenient for handling and storage. Manufacturer's name or symbol and catalog number shall be on each part or (and) its packaging.

**Approved Manufacturers:**

PUD IDENTIFICATION		MANUFACTURER CATALOG NUMBER		
Stock Description	Stock No.	MACLEAN	HUBBLE	PREFORMED
Clevis, Socket, Short, 5/8" Pin, 2 5/8" from Socket to Pin, Ductile Iron, Hd Galv, 30,000 Lb Ultimate Strength.	014950	SC-55	SC30	SC-5194



**GUYING ANCHOR, CROSS PLATE**

Originator: DSmith

Date: 7/28/2006

Approval: DSmith

Date: 7/3/2007

Page 1 of 1

Revision: **NEW**

Stds Committee Approval:  
**Approved**

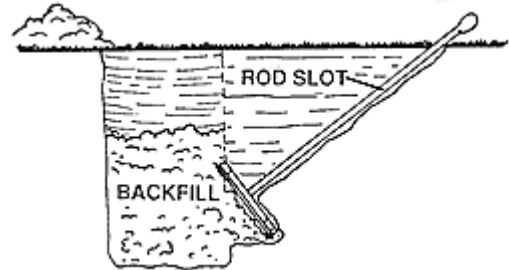

**Application:** The Cross-Plate anchor is made for installation in holes drilled by power diggers. Because the size of the hole does not affect holding capacity, the hole can be dug by the same auger that is used to dig the pole holes on transmission projects. Cross-Plate anchors are installed in a diagonal bored hole which is undercut so the anchor is at right angles to the guy.

A rod trench is either cut with a trenching tool or drilled with a small power auger. Both anchor and rod trench should be refilled and tamped.

**Packaging and Marking:** Items shall be suitably packaged to prevent damage. The container shall be convenient for handling and storage. Manufacturer's name or symbol and catalog number shall be on each part or (and) its packaging.

**Approved Manufacturers:**

PUD IDENTIFICATION		MANUFACTURER CATALOG NUMBER	
Stock Description	Stock No.	Chance	
ANCHOR, 24" CROSS PLATE	005255	X24	



**GUY ANCHOR  
EXPANDING ROCK**

Originator: DSmith      Date: 7/7/06

Approval: DSmith      Date: 7/7/06

Revision: J Mitchell      Date: 9/13/10

Stds Committee Approval:  
**Approved**



**Application:** Used to guy utility poles in solid rock. A hole is drilled into the rock to a minimum 12 inch depth in line with the guy. The anchor is placed into the hole and a bar through the eye is used to turn and expand the anchor into the rock. The anchor expands and wedges against the wall of the rock.

**Specification:** List requirements as needed to describe the properties of the item. If necessary, use blanks ( ) in description and add any of the following.

Dimensions:

Strength: Shall be capable of holding 23,000 pounds

Material: GALVANIZED Steel

Finish: The item shall be hot dipped galvanized

**Packaging and Marking:** Items shall be suitably packaged to prevent damage. The container shall be convenient for handling and storage. Manufacturer's name or symbol and catalog number shall be on each part or (and) its packaging.

**Shipping:** Special Shipping Instructions

**Approved Manufacturers:**

PUD IDENTIFICATION		MANUFACTURER CATALOG NUMBER	
Stock Description	Stock No.	HUBBELL	JOSLYN
ANCHOR, ROCK, 15"x3/4", TRIPLE EYE	005380	R315	J3436
ANCHOR, ROCK, 30"x3/4", TRIPLE EYE	005400	R330	J3437
ANCHOR, ROCK, 53"x3/4", TRIPLE EYE	005420	R353	J3438
ANCHOR, ROCK ,53"x 1", TRIPLE EYE	005460	R153L	JR153L
ANCHOR, ROCK ,72"x3/4", TRIPLE EYE	005440	R372	JR372
ANCHOR, ROCK ,72"x 1", TRIPLE EYE	005480	R172L	JR172L



### GUY ANCHOR, MULTIPLE HELIX SCREW ANCHOR

Originator: DSmith

Date: 8/8/2013

Approval: DSmith

Date: 8/8/2013

Page 1 of 1

Revision: **NEW**

Stds Committee Approval:  
**Approved**

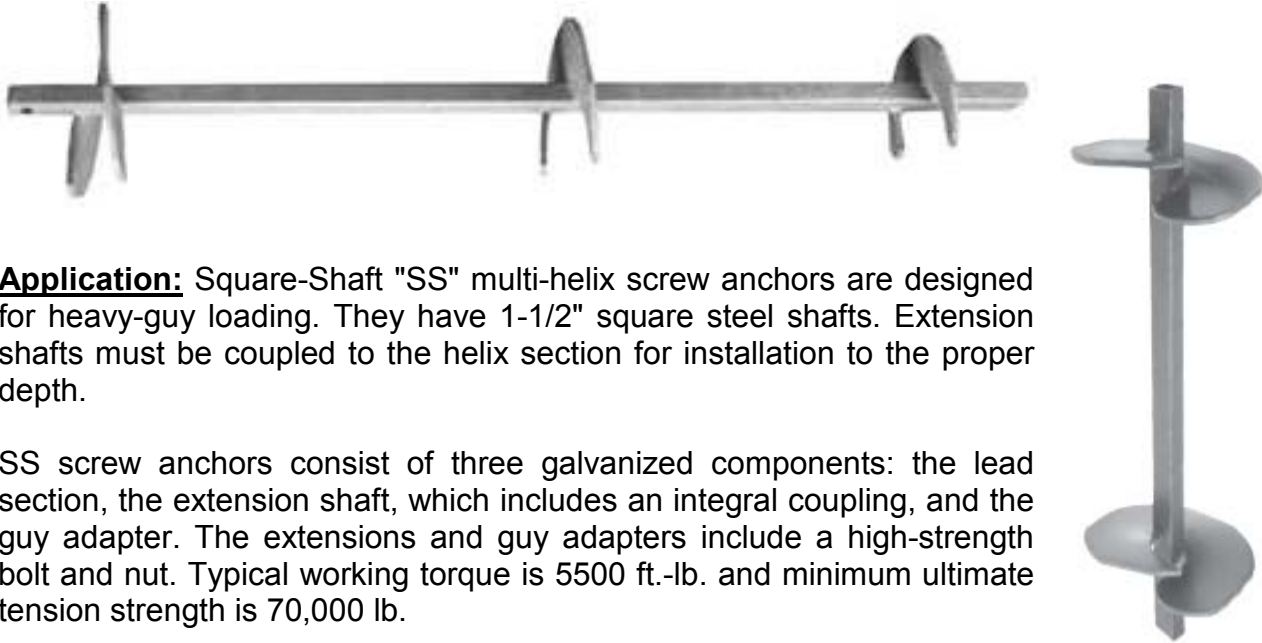

**Application:** Square-Shaft "SS" multi-helix screw anchors are designed for heavy-guy loading. They have 1-1/2" square steel shafts. Extension shafts must be coupled to the helix section for installation to the proper depth.

SS screw anchors consist of three galvanized components: the lead section, the extension shaft, which includes an integral coupling, and the guy adapter. The extensions and guy adapters include a high-strength bolt and nut. Typical working torque is 5500 ft.-lb. and minimum ultimate tension strength is 70,000 lb.

**Packaging and Marking:** Items shall be suitably packaged to prevent damage. The container shall be convenient for handling and storage. Manufacturer's name or symbol and catalog number shall be on each part or (and) its packaging.

**Approved Manufacturers:**

PUD IDENTIFICATION		MANUFACTURER CATALOG NUMBER
Stock Description	Stock No.	Chance
ANCHOR, LEAD SECTION, 7", 8", 10", OR 12" TRIPLE HELIX	005220	012642-AEJ



**GUYING, ANCHOR RODS  
 Extensions, Eye Nuts & Couplings**

Originator: DSmith

Date: 8/19/2013

Approval: J. Mitchell

Date: 10/23/2014

Page 1 of 1

Revision: **Added MacLean Catalog Numbers**

Std's Committee Approval:  
**Approved**

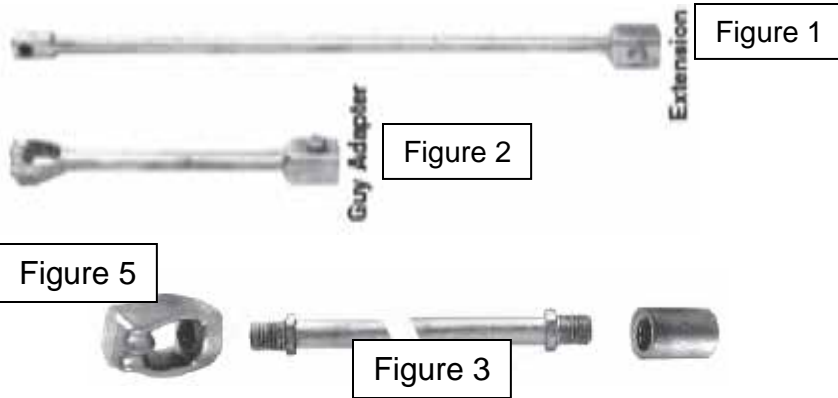

**Application:** Attached to Plate Anchor or screw anchor and guy wire. .

**Packaging and Marking:** Items shall be suitably packaged to prevent damage. The container shall be convenient for handling and storage. Manufacturer's name or symbol and catalog number shall be on each part or (and) its packaging.

Stock No.	PUD IDENTIFICATION		MANUFACTURER CATALOG NUMBER	
	Stock Description	Fig #	Chance	MacLean
005210	ANCHOR, GUY ADAPTER, 18" TRIPLE EYE W/HIGH STRENGTH BOLT AND NUT	2	C102-0025	
005230	ANCHOR, EXTENSION SHAFT, 7' W/HIGH STRENGTH BOLT AND NUT	1	12657	
005240	ANCHOR, EXTENSION SHAFT, 10' W/HIGH STRENGTH BOLT AND NUT (SWAMP)	1	12658	
005260	ANCHOR, EXTENSION SHAFT, 3.5' W/HIGH STRENGTH BOLT AND NUT	1	12655	
005530	ANCHOR, EXTENSION ROD, 1" X 3 1/2' THREADED BOTH ENDS W/COUPLER, GALV	3	12251A J	D10031/2C
005580	ANCHOR, EXTENSION ROD, 1" X 7', THREADED BOTH ENDS W/COUPLER, GALV	3	12334P	D100
005650	ANCHOR, ROD, 1" X 8' THREADED W/SQ NUT, TRIPLE EYE, GALV	4	7568	
005660	ANCHOR, ROD, 1" X 10' THREADED W/SQ NUT, TRIPLE EYE, GALV	4	7570	
005000	ANCHOR, DBL EYENUT, 3/4" BOLT HOLE	5		
005320	ANCHOR, DBL EYENUT, 1" BOLT HOLE	5	6562	
005330	ANCHOR, TRIPLE EYENUT, 1" BOLT HOLE	5	12585	D6567





**GUY GRIP, DEAD END**

Originator: DSmith

Date: 7/28/2006

Approval: DSmith

Date: 7/9/2007

Page 1 of 1

Revision: **NEW**

Stds Committee Approval:  
**Approved**



**Acceptable Fittings**

<p><b>Anchor Rods</b></p>	<p><b>Thimble Eye-Bolts, Eye-ends &amp; Eyes</b></p>	<p><b>Pole Fittings</b></p>	<p><b>Guy-Strain Insulators</b></p> <p style="text-align: center;">ANSI S4-1 S4-2 S4-3 S4-4</p>
---------------------------	--	-----------------------------	---

**CAUTION:**  
Hardware of this type is not normally acceptable because fatigue life of GUY-GRIP dead-ends could be substantially reduced.

Heavy-Duty-Type Cable Thimbles, if used, can collapse when guy tensions are high. If thimbles are used in the loop of the GUY-GRIP dead-end, a large pin is recommended to fill the loop of the thimble to prevent distortion. The collapsing strength of the thimble and the proper pin size should be obtained from the thimble manufacturer.

**Application:** GUY-GRIP dead-ends are intended for use on single wood poles and Aluminum Clad Steel Strand down guy wire associated with distribution construction. GUY-GRIP dead-ends were not designed or tested for use on overhead shield wires and not intended for that application.

**Packaging and Marking:** Items shall be suitably packaged to prevent damage. The container shall be convenient for handling and storage. Manufacturer's name or symbol and catalog number shall be on each part or (and) its packaging.

**Approved Manufacturers:**

PUD IDENTIFICATION		MANUFACTURER CATALOG NUMBER		
Stock Description	Stock No.	PLP	Helical Line Products	DULMISON
GRIP, GUY, 6M, DEADEND, BLUE	019500	AWDE-4110	HG517-6M	TBD
GRIP, GUY, 12.5M DEADEND, YELLOW	019550	AWDE-4119	HG523-12.5M	AWGG-0870
GRIP, GUY, 1/2" (7STR) #6 DEADEND, BLUE	019580	AWDE-4128	HG530-7 #6	TBD
GRIP, GUY, 25M DEADEND, RED	019600	AWDE-4130	HG531-25M	AWGG-1310



**GUY GUARDS**

Originator: DSmith

Date: 12/19/2006

Approval: DSmith

Date: 7/9/2007

Page 1 of 1

Revision: **NEW**

Stds Committee Approval:

12/19/06



**Application:** Guy Guards are designed to identify Down Guys or other wire and cable installations where anchoring devices are exposed to pedestrian and/or vehicular traffic.

**Specification:** Each 8' long unit shall be made of 1-1/2" OD bright yellow round polyethylene that is UV resistant with a slotted top end. Each unit shall have an integral helix grip (pigtail) and locking strap that prevents the unit from sliding after initial installation.

**Packaging and Marking:** Items shall be suitably packaged to prevent damage. The container shall be convenient for handling and storage. Manufacturer's name or symbol and catalog number shall be on each part or (and) its packaging.

**Approved Manufacturers:**

PUD IDENTIFICATION		MANUFACTURER CATALOG NUMBER		
Stock Description	Stock No.	PLP		
GUARD, GUY, 1-1/2" O.D. YELLOW - ROUND, 8' LONG, UV RESISTANT POLYETHYLENE	027500	PG-5718		



**GUY HOOKS**

Originator: DSmith

Date: 7/28/2006

Approval: DSmith

Date: 7/5/2007

Page 1 of 1

Revision: **NEW**

Stds Committee Approval:  
**Approved**

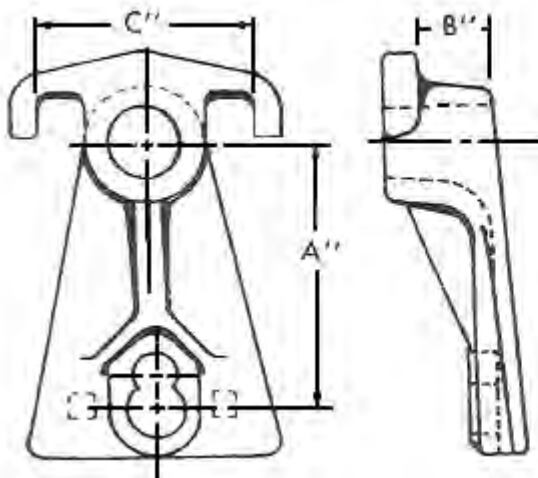

**Figure 1**

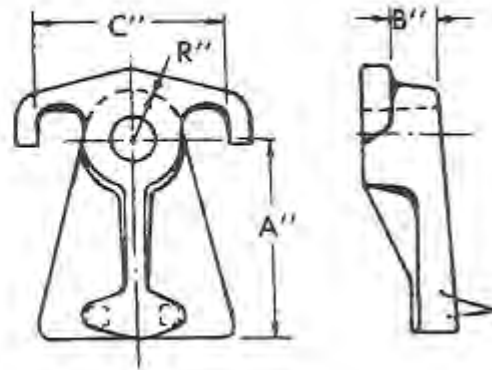

**Figure 2**

**Application:** Guy Hook, cast ductile iron, for down guy applications. Mounts with 3/4" through bolt and has cast integral lag spur.

**Specifications:** Integral Lag Type, Malleable Iron, Hot Dipped Galvanized. Ultimate Strength (lbs) is measured at 45° downward pressure

**Packaging and Marking:** Items shall be suitably packaged to prevent damage. The container shall be convenient for handling and storage. Manufacturer's name or symbol and catalog number shall be on each part or (and) its packaging.

**Approved Manufacturers:**

PUD IDENTIFICATION			MANUFACTURER CATALOG NUMBER		
Stock Description	Stock No.	Figure	MIF	MacLean	Chance Hubbell
HOOK, GUY, SMALL, 20K Lbs, 5/8" BOLT HOLE	020750	2	P133A	P133AX	GH5ILS
HOOK, GUY, MEDIUM, 25K Lbs, 3/4" & 1/2" BOLT HOLES	020770	1	P132C	G-764X2	TBD
HOOK, GUY, LARGE, 25K Lbs, 1" & 1/2" BOLT HOLES	020780	1	P132B	G-864X2	TBD



**SINGLE & DOUBLE POLE EYE PLATES**

Originator: Jeff Flader

Date: 1/25/2012

Approval: Jeff Flader

Date: 1/25/2012

Page 1 of 1

Revision: **NEW**

Stds Committee Approval:  
**Pending**

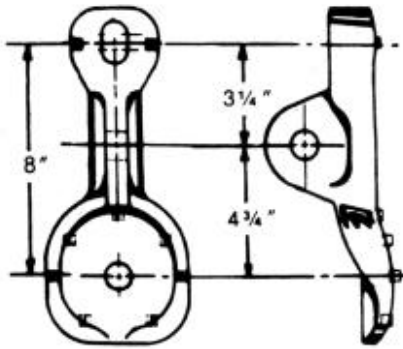
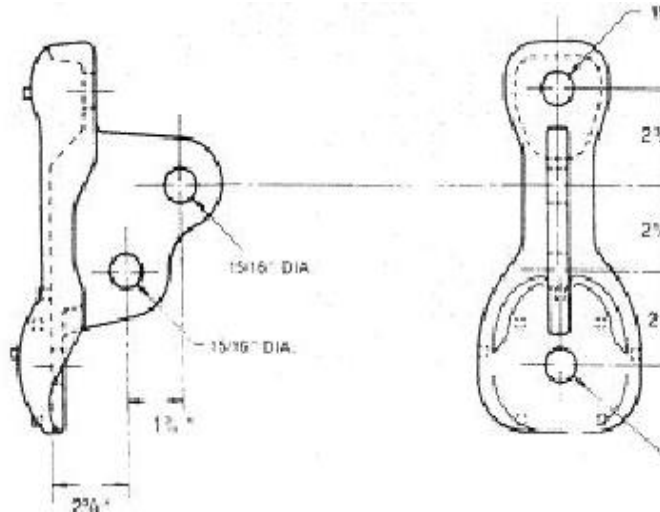

FIG. 1



**Application:** Pole Eye plates are used to dead end both conductor and/or guying.

**Common Name:** Pole Eye Plate

**Ordering Description:**

- Single Pole Eye Plate – Plate, Pole, Single Eye, Hd Galv, 15/16" Bolt Holes With 8" Spacing, 15/16" Pin Holes.
- Double Pole Eye Plate – Plate, Pole, Double Eye, Hd Galv, 11 3/8" Total Length, 15/16" Bolt Holes With 8" Spacing, 15/16" Pin Holes.

**Packaging and Marking:** Items shall be suitably packaged to prevent damage. The container shall be convenient for handling and storage. Manufacturer's name or symbol and catalog number shall be on each part or (and) its packaging.

**Approved Manufacturers:**

PUD IDENTIFICATION		MANUFACTURER CATALOG NUMBER	
Stock Description	Stock No.	MACLEAN	HUBBELL
Plate, Pole, Single Eye, Hd Galv, 15/16" Bolt Holes With 8" Spacing	086790	EPR-877	
Plate, Pole, Double Eye, Hd Galv, 15/16" Bolt Holes With 8" Spacing	086800	EPR-877-D7RE OR EPR-877-D7RE-LT	



**VIBRATION DAMPERS**

Originator: Jeff Flader

Date: 7/10/2012

Approval: Jeff Flader

Date: 9/25/2013

**USED WITHOUT ARMOR RODS**



**Application:** Vibration dampers work to cancel damaging fatigue caused by wind-induced vibration. Most tuned damping devices operate best near their natural frequencies. Vibration dampers are designed for efficient transfer and dissipation of energy over a wide spectrum of frequencies.

**Common Name:** Vibration Dampers

**Ordering Description:** Use tables below to order by conductor size and type. Actual damper weight may vary. Exact bolt size is not critical for the correct fit, but all connector bolts should be breakaway and removable. Dampers are sized for specific conductor sizes so weights may vary.

**Packaging and Marking:** Items shall be suitably packaged to prevent damage. The container shall be convenient for handling and storage. Manufacturer's name or symbol and catalog number shall be on each part or (and) its packaging.

**Approved Manufacturers:**

PUD IDENTIFICATION  Stock Description	MANUFACTURER CATALOG NUMBER		
	Stock No.	ALCOA	PREFORMED
DAMPER, VIBRATION, (3/8" - .375 STATIC WIRE), USED W/OUT ARMOR ROD – W/BREAKAWAY BOLTS.	085910	1701-3BA	DB-05-09-SH
DAMPER, VIBRATION, (2/0 ACSR - .447), USED W/OUT ARMOR ROD – W/BREAKAWAY BOLTS.	085900	1703-3BA	VSD-1012-B
DAMPER, VIBRATION, (4/0 ACSR - .563), USED W/OUT ARMOR ROD – W/BREAKAWAY BOLTS.	085902	1703-4BA	VSD-2016-B
DAMPER, VIBRATION, (336 AAC - .666), USED W/OUT ARMOR ROD – W/BREAKAWAY BOLTS.	085911	1704-5BA	VSD-2020-B
DAMPER, VIBRATION, (336 ACSR - .720), USED W/OUT ARMOR ROD –W/BREAKAWAY BOLTS.	085904	1704-6BA	VSD-2020-B
DAMPER, VIBRATION, (636 AAC - .918), USED W/OUT ARMOR ROD – W/BREAKAWAY BOLTS.	085912	1705-8BA	VSD-3525-B
DAMPER, VIBRATION, (636 ACSR - .990), USED W/OUT ARMOR ROD –W/BREAKAWAY BOLTS.	085906	1706-9BA	VSD-4032-B
DAMPER, VIBRATION, (795 ACSR – 1.108 & 954 AAC – 1.124 ), USED W/OUT ARMOR ROD - W/BREAKAWAY BOLTS.	085908	1706-10BA	VSD-4032-B
DAMPER, VIBRATION, (1272 ACSR – 1.345 ), USED WITHOUT ARMOR ROD – WITH BREAKAWAY BOLTS.	085913	1707-13BA	VSD-4040-B



**POLE GAINS AND SHIMS**

Originator: DSmith

Date: 7/28/2006

Approval: DSmith

Date: 7/5/2007

Page 1 of 1

Revision: **NEW**

Stds Committee Approval:  
**Approved**



**Pole Gains**

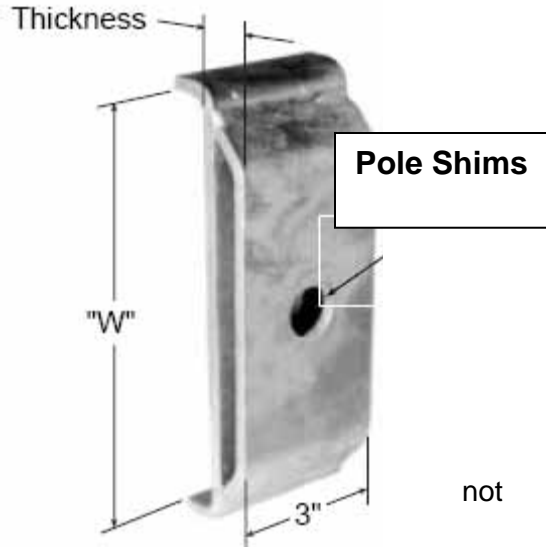
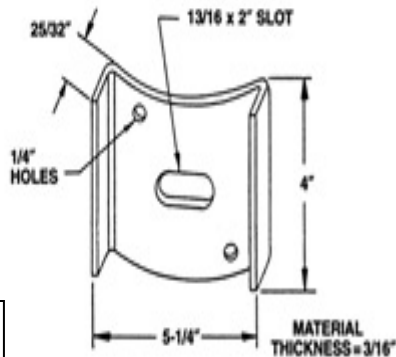

**Application:** Pole gains enhance the stability of the crossarm and pole interface. They are used where it is possible or desirable to cut a gain in the pole.

Pole Shims are used in double arm assemblies, when the variations between pole diameters occur on H-Frame structures. Shims are used as an alternative to gaining the larger pole in and used predominantly in maintenance applications.

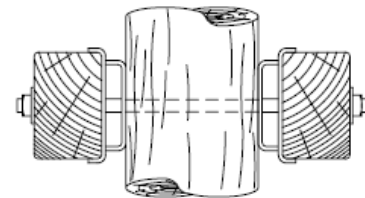

**Specification:** The item shall be made of hot dipped galvanized steel per ASTM A153.

**Packaging and Marking:** Items shall be suitably packaged to prevent damage. The container shall be convenient for handling and storage. Manufacturer's name or symbol and catalog number shall be on each part or (and) its packaging.

PUD IDENTIFICATION		MANUFACTURER CATALOG NUMBER		
Stock No.	Stock Description	MACLEAN	JOSLYN	HUGHES BROS
019020	GAIN, DUCTILE IRON, 6-3/4"x4", 7/8" BOLT HOLE	GCA 74-7	PX262B	
019050	GAIN, 5-1/4"x4" CURVED, 2"x3/4" SLOT HOLE		J4060	HUBBELL: DG9M1
019055	GAIN, POLE, BRACELESS, GALV			CONTINENTAL #DEA-65-10B
019060	GAIN, STUBBING	MIF #PX148E		CONTINENTAL #GRR-54-11
085860	GAIN, TIMBER, GALV, 3" DIA, 13/16" CENTER HOLE	MIF #PX-157C		
086810	POLE SHIM 7-3/4" X 1-1/2" X 3"			2844-15H
086820	POLE SHIM 7-3/4" X 1" X 3"			2844-10H





**CROSSARM BRACE  
WISHBONE or SPAN BRACE**

Originator: DSmith

Date: 7/28/2006

Approval: DSmith

Date: 7/5/2007

Page 1 of 1

Revision: **NEW**

Stds Committee Approval:  
**Approved**



**Flat Brace**

**Wishbone Brace**

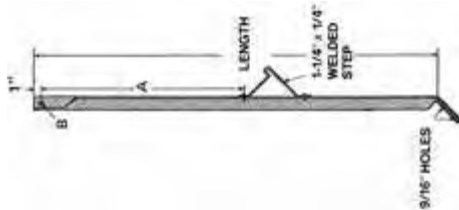

**Alley Arm**

**Application:** Flat & Wishborn braces are used to align an support wooden crossarms.

The Steel Alley Arm Brace is used where the arms are mounted on one side of the pole. The brace end is flattened for the pole or arm attachment and mounted at a 45 degree angle.

**Specification:** Each unit shall be made of Hot Dipped Galvanized steel per ASTM A153.

**Packaging and Marking:** Items shall be suitably packaged to prevent damage. The container shall be convenient for handling and storage. Manufacturer's name or symbol and catalog number shall be on each part or (and) its packaging.

**Approved Manufacturers:**

PUD IDENTIFICATION		MANUFACTURER CATALOG NUMBER	
Stock No.	Stock Description	HUBBELL	JOSLYN
012400	BRACE, ALLEY ARM, HD GALV ANGLE IRON BRACE, 2" X 2" X 1/4", 10'	DB7L2	J1526
012528	BRACE, XARM, 28" FLAT, HD GALV	7128	J7128
012530	BRACE, WISHBONE, 42" SPAN, 12" DROP, ANGLE STEEL, HD GALV	69401	J1506
012550	BRACE, WISHBONE, 60" SPAN, 18" DROP, ANGLE STEEL, HD GALV	69421	J1508
012570	BRACE, WISHBONE, 72" SPAN, 22" DROP, ANGLE STEEL, HD GALV	----	J1512





**GROUNDING CLAMP, SUSPENSION,  
DUCTILE IRON  
w/ Socket Connector**

Originator: DSmith

Date: 12/6/06

Approval: DSmith

Date: 7/5/2007

Page 1 of 1

Revision: Revised Catalog Numbers to Include Socket

Stds Committee Approval:  
**Approved**

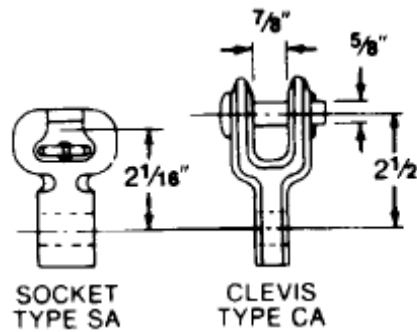
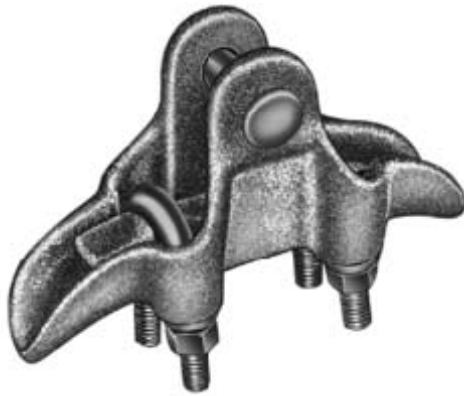

**Application:** For ground wire application with galvanized steel cable with or without armor rods. Includes socket fitting for use with Class 52-3 or 52-3 insulators.

May also be used to suspend copper or Copperweld® cable, but Magnetic induction heating will occur.

Recommended Torque on U-bolts = 40-45 ft/lbs

**Specification:** Body and Keeper—ductile iron, galvanized  
Hardware—galvanized steel  
Cotter Pin—#302 stainless steel

**Packaging & Marking:** Items shall be suitably packaged to prevent damage. The container shall be convenient for handling and storage. Manufacturer's name or symbol, catalog number, and cable range shall be on each part and its packaging.

**Approved Manufacturers:**

PUD IDENTIFICATION		MANUFACTURER CATALOG NUMBER				
Stock Description	Stock No.	Min Body Strength (LBS)	Cable Range	MacLean	Hubbell	Mfg #3
Clamp, Susp, Galv Ductile Iron, W/ Socket, #2-250 Grdwire, Galv Steel, Cu Or CWELD	014530	16,000	.20" - .60"	FSC-60-S	MS60S	-----
Clamp, Susp, Galv Ductile Iron, W/ Socket, #2/0-500 Grdwire, Galv Steel, Cu Or CWELD	014540	18,000	.40" - .83"	FSC-83-S	MS83S	-----

- Material Standards -

1616.03

CHELAN COUNTY  
**PUBLIC UTILITY DISTRICT**  
*Owned By The People We Serve*



# LINE HARDWARE SWITCH OPERATOR PLATFORM GROUND MOUNTED

Originator:  
**J. Flader**

Standards Approval:  
**C. Bowman**

Approval:  
**C. Bowman**

Date:  
**6/8/2012**

Page 1 of 1

Rev #: Revision Description:

0

**SWITCH OPERATOR PLATFORM-GROUND MOUNTED**

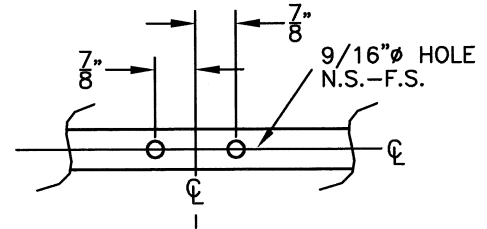
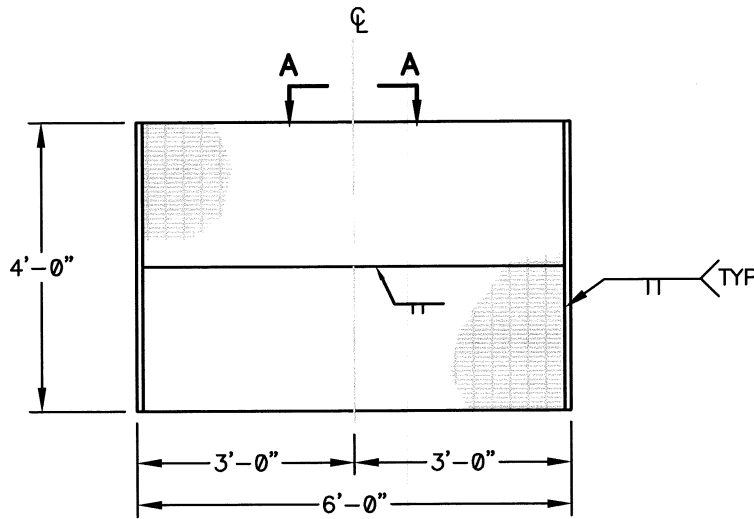

**SECTION A-A**

**SWITCH OPERATOR PLATFORM**

PUD IDENTIFICATION		MANUFACTURER
STOCK NO.	STOCK DESCRIPTION	
026205	PLATFORM, SWITCH OPERATING 4' X 6' GALVANIZED	* SEE NOTES

**FABRICATION NOTES: \***

1. ALL STEEL - ASTM A36 U.N.O.
  2. GALV. AFTER FABRICATION PER ASTM A123
  3. SMOOTH GRATING -  
1" x 3/16" BARS  
1 3/16" C TO C  
W/4" C TO C X-BARS
  4. 3/16 X 1 BAR END BANDING REQUIRED
- ORIGINAL BUILDING PRINT #05-WW-05 - ORIGINAL JOB NAME IS MCKENZIE SWITCHYARD  
REF, DWG: SKETCHES - ATTN: STEVE KNOX.



**MOLDING, FLAT FLEXIBLE COPPER BRAID**

Originator: DSmith

Date: 7/28/2006

Approval: DSmith

Date: 7/5/2007

Page 1 of 1

Revision: **NEW**

Stds Committee Approval:  
**PENDING**



**Application:** This tin plated Flexible Copper Braid is designed to take up the expansion or misalignment between two pieces of equipment. Drilled for standard NEMA hole spacing

**Packaging and Marking:** Items shall be suitably packaged to prevent damage. The container shall be convenient for handling and storage. Manufacturer's name or symbol and catalog number shall be on each part or (and) its packaging.

**Approved Manufacturers:**

PUD IDENTIFICATION		MANUFACTURER CATALOG NUMBER
Stock Description	Stock No.	PENN UNION
COPPER BRAID, FLAT, FLEXIBLE 24"	013000	FXBA24NQ



**GROUNDING CABLE TO FLAT BAR**

Originator: DSmith

Date: 7/5/2007

Approval: DSmith

Date: 6/8/2009

Page 1 of 1

Revision: Eliminated Galvanized Hardware

Stds Committee Approval:  
**Approved**



**Application:** Bronze alloy ground clamp for clamping a copper cable to flat bar. Cable groove in bottom piece prevents excessive cable distortion.

**Specification:** Castings—bronze alloy  
Hardware— Stainless Steel or Bronze Alloy

**Packaging & Marking:** Items shall be suitably packaged to prevent damage. The container shall be convenient for handling and storage. Manufacturer’s name or symbol, catalog number, and cable range shall be on each part and its packaging.

**Approved Manufacturers:**

PUD IDENTIFICATION		MANUFACTURER CATALOG NUMBER		
Stock Description	Stock No.	Hubbell	Dossert	
CLAMP, GROUNDING, BRONZE, CABLE TO FLAT, #6 SOL - 2/0 STR – 3/8” BOLT	014750	GC-141-3-01	GF-13	
CLAMP, GROUNDING, BRONZE, CABLE TO FLAT, #4 SOL - 300KCM – 1/2” BOLT	014780	GC-141A-02	GF-30	



# INSULATORS

Originator: DSmith

Date: 1/24/2007

Approval: DSmith

Date: 2/8/2007

Page 1 of 1

Revision: **NEW**

Stds Committee Approval:  
**Approved**

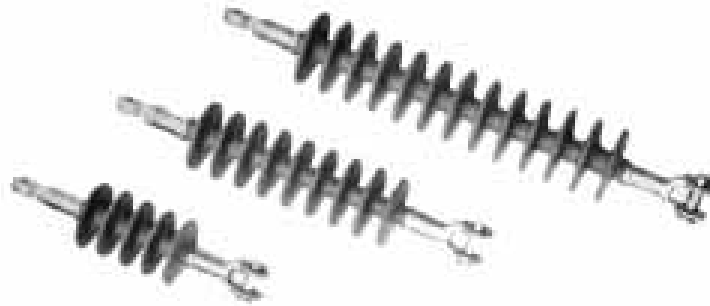

# SECTION 1700 INSULATORS

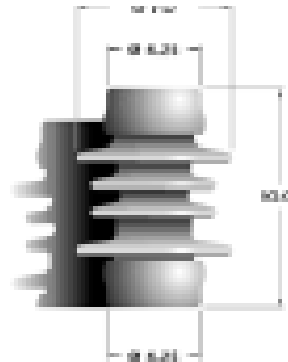



**Insulators, Transmission, Polymer  
Suspension & Dead End**

Originator: DSmith

Date: 5/14/0212

Approval: J Flader

Date: 5/11/2013

Page 1 of 2

Revision: Added Spec #9. Updated Manufacturer catalog numbers.

Stds Committee :Approved

**Specification:** Composite suspension insulator shall comply with the latest revision of IEEE P1024 and meet the following requirements:

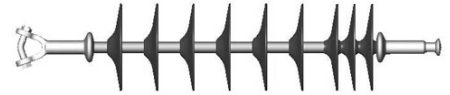

1. Weather Sheds: Non-tracking elastomer such as EPDM Rubber OR EP Silicone.
2. Core: Fiberglass Rod
3. End Fittings: Aluminum alloy 356-T6 or galvanized malleable iron ASTM A47M
4. Construction: The weather sheds shall be one piece molded type, fully bonded to the core. The end fitting/weather shed interface shall be sealed from moisture entry and free of voids. End fittings shall be attached to the core by swaging (compression). Color: Shall be Sky Gray.
5. Tests: Insulators shall be tested per latest revision of ANSI C29.1 Test Methods for Electric Power Insulators. Every insulator in production runs shall be given a routine tension load proof test per ANSI C29.1 and manufacturer's published proof test load rating.
6. Line Fitting: ANSI 52-5 Ball
7. Tower Fitting: Y Clevis
8. Corona Ring Required On 230Kv Units District Stock #021437 – Line end only
9. Units for which manufacturer requires or recommends the use of corona rings for District Stock # 021436 or #021435 will not be accepted.

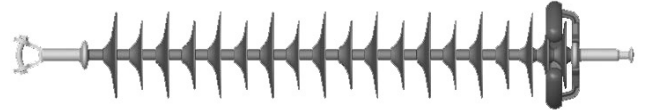

Stock #	P-P Line Voltage	ideal Section Length (in)	Strength Class (lbs)	Working Load (lbs)	Leakage (in)	Dry Arc Distance	Dry Electrical Flashover (kV) 60 Hz	Wet Electrical Flashover (kV) 60 Hz	ANSI Critical Impulse FO - Positive	ANSI Critical Impulse FO - Negative
021436	115kv	41	25,000	12,500	76	30.7	310	295	505kV	490kV
021435	115kv	53	25,000	12,500	107	42.9	430	405	700kV	695kV
021437	230kV	102	30,000	15,000	228	91.7	855	790	1440	1465

**Approved Manufacturers**

PUD IDENTIFICATION		MANUFACTURER CATALOG NUMBER			
Stock Description	Stock No.	Hubbell	Sediver	MacLean	NGK-Locke
Insulator, Polymer, Suspension, 115kv, min of 40.5", max of 44.5" Ball & Y Clevis ends	021436	511005-1201 (40.7")	SEDNYB120XL29E0 (42.8")	S148041MX01 (41.7")	251-SS280-YJ (44.3")
Insulator, Polymer Suspension. 115kv, min. of 53", max. of 55" Ball & Y Clevis ends.	021435	511007-1201 (53")	SEDNYB120XL39E0 (53.6")	S148054MX01 (54.3")	251-SS350-YJ (53")
Insulator, Polymer Suspension, 230kv, min of 102", max. of 111", Ball & Y Clevis ends. Ring on line side only	021437	515015-1201 (102")	SEDNYB180XL87E1 (106")	S548111FB02 (111")	251-SS780-YJ-08 (103")



**Insulators, Transmission, Polymer  
Suspension & Dead End**

Originator: DSmith

Date: 5/14/0212

Approval: J Flader

Date: 5/11/2013

Page 2 of 2

Revision: Added Spec #9. Updated Manufacturer catalog numbers.

Stds Committee :Approved

**Packaging & Marking:** Items shall be suitably packaged to prevent damage. The container shall be convenient for handling and storage. Manufacturer's name or symbol, catalog number, strength rating and date code shall be permanently marked on each part and its packaging.





**INSULATORS, HORIZONTAL LINE POST  
TRANSMISSION - Polymer**

Originator: DSmith

Date: 9/25/2013

Approval: Jeff Flader

Date: 5/11/2013

Revision: Specs

Page 1 of 1  
Stds Committee:  
**Approved**

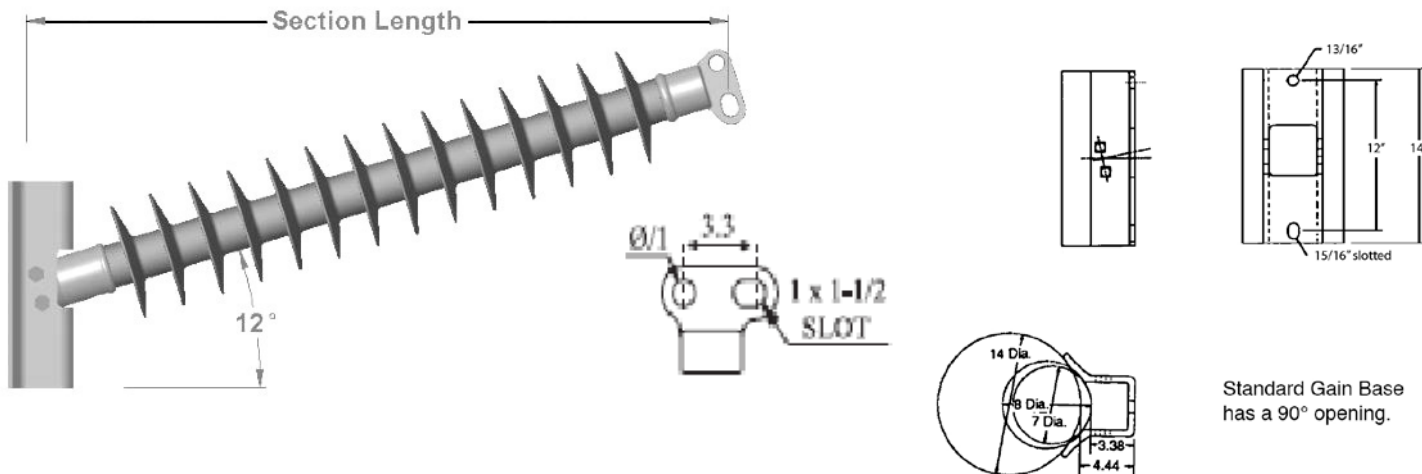

**Application:** Post insulators described in this standard are for transmission line construction. Maximum design tension shall be 2500 lbs.

**Specifications:**

**Insulators:** shall be manufactured from a fiberglass rod with Polymer weather sheds. Insulators shall be rated and tested in accordance with ANSI C29.11

**Horizontal End Fittings** shall be galvanized steel or ductile iron two hole blade with 1" hole and 1" x 1 1/2 slot.

**Horizontal Mounting Base** shall be bendable aluminum or galvanized steel gain style with 90 degree opening with (1) 13/16" diameter hole and (1) 15/16" diameter elongated hole on 12" spacing. Insulator shall be offset from horizontal by 12 degrees.

Units for which manufacturer requires or recommends the use of corona rings for District Stock # 021760 will not be accepted.

**Packaging and Marking:** Each insulator shall be individually packaged & permanently marked with the manufacturer's name and catalog number.

Stock No.	PUD IDENTIFICATION Stock Description	MANUFACTURER CATALOG NUMBER		
		Hubbell/OHIO BRASS	MacLean	NGK-LOCKE
021761	Insulator 115kv Horiz Post Polymer W/ Bendable Gain Base & Two Hole Blade End Fitting - 2500#, Approximate Length 55"	<b>522008-1002</b> 54.5 inches	<b>NBSG30XH028S0</b> 52.6 Inches	<b>L2-SN291-13</b> 53.8 Inches
021766	Insulator 230kv Horiz Post Polymer W/ Bendable Gain Base & Two Hole Blade End Fitting - 2500#, Approximate Length 96 "	<b>522016-1002</b> 96.3 inches	H291096FA02 96 Inches	L3-SN581-13 95.7 Inches



**INSULATORS  
INSULATORS, VERTICAL LINE POST  
FACE MOUNT, 115 KV-POLYMER**

Originator: <b>J. Flader</b>	Standards Approval: <b>Jeff Flader</b>
Approval: <b>J. Flader</b>	Date: <b>9/12/2013</b>

Rev #:	Revision Description:
<b>0</b>	<b>SPECS</b>

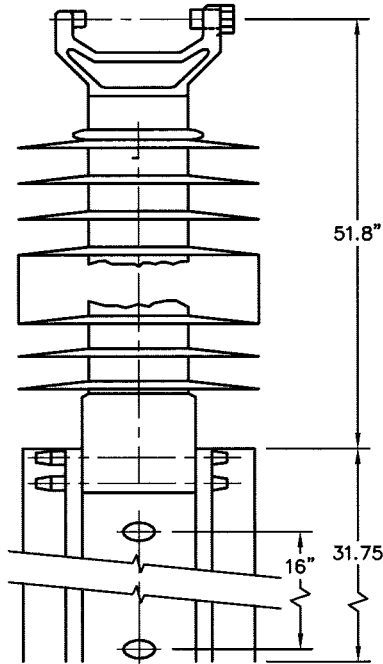

FACE MOUNT

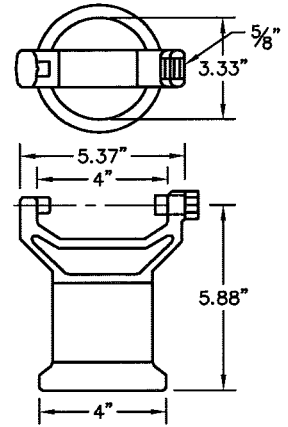
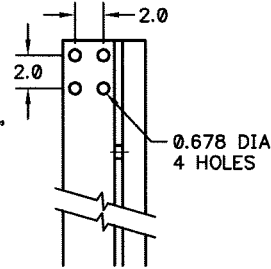
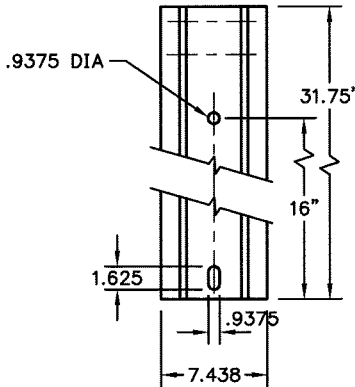
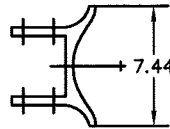

VERTICAL CLAMPTOP  
PART PER ANSI C29.7

STOCK NO.	STOCK DESCRIPTION	MANUFACTURER CATALOG NUMBER			
		HUBBELL/OHIO BRASS	SEDIWER	MACLEAN	NGK-LOCKE
021825	INSULATOR, VERTICAL POST, FACE MOUNT, POLY, 115KV, 51.8", W/ 31.75" BRACKET, TOTAL LENGTH 83.55". SEE DRAWINGS & SPECIFICATIONS FOR MORE DETAIL.	522008-1226	NOT AVAILABLE	NOT AVAILABLE	NOT AVAILABLE

**SPECIFICATIONS:**

**INSULATORS:** SHALL BE MANUFACTURED FROM A FIBERGLASS ROD WITH NON TRACKING ELASTOMER, SUCH AS EPDM RUBBER OR EP SILICONE WEATHER SHEDS. INSULATORS SHALL BE RATED AND TESTED IN ACCORDANCE WITH ANSI C29.11

**VERTICAL CLAMPTOPS** PART PER ANSI C29.7 AND GALVANIZED STEEL

**HORIZONTAL MOUNTING BASE** SHALL BE BENDABLE ALUMINUM OR GALVANIZED STEEL GAIN STYLE WITH (2) HOLES ON 16" CENTERS. THE TOP HOLE WILL BE .9375" DIAMETER AND THE BOTTOM HOLE WILL BE ELONGATED AND .9375" X 1.625"

UNITS FOR WHICH MANUFACTURER REQUIRES OR RECOMMENDS THE USE OF CORONA RINGS WILL NOT BE ACCEPTED

**PACKAGING AND MARKING:** EACH INSULATOR SHALL BE INDIVIDUALLY PACKAGED AND PERMANENTLY MARKED WITH THE MANUFACTURER'S NAME AND CATALOG NUMBER.



**INSULATORS**  
**INSULATORS, VERTICAL LINE POST**  
**SIDE MOUNT, 115 KV-POLYMER**

Originator: **J. Flader**

Standards Approval: **Jeff Flader**

Approval: **J. Flader**

Date: **9/12/2013**

Rev #: Revision Description:

**0** **SPECS**

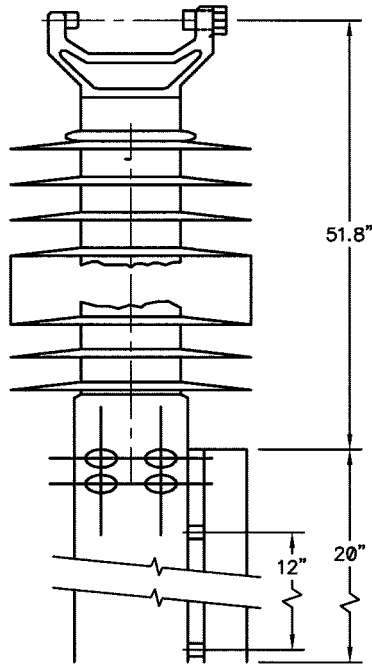

SIDE MOUNT

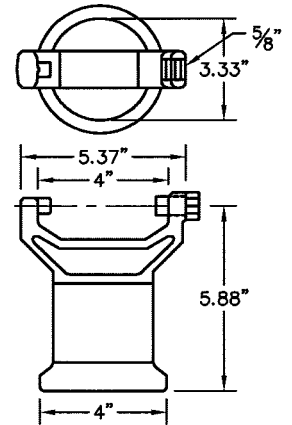
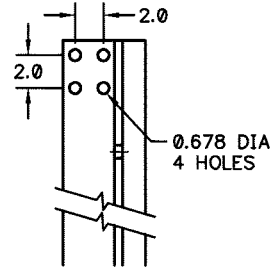
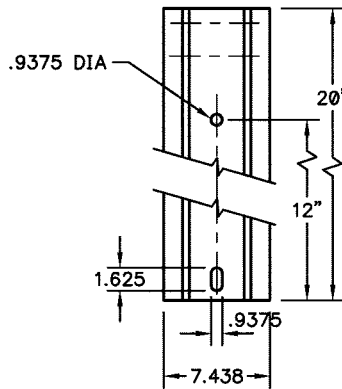
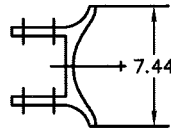

VERTICAL CLAMPTOP  
PART PER ANSI C29.7

STOCK NO.	PUD IDENTIFICATION	MANUFACTURER CATALOG NUMBER			
	STOCK DESCRIPTION	HUBBELL/OHIO BRASS	SEDIWER	MACLEAN	NGK-LOCKE
021820	INSULATOR, VERTICAL POST, SIDE MOUNT, POLY, 115KV, 51.8", W/ 20" BRACKET, TOTAL LENGTH 71.8", 4" CLAMP TOP	522008-1223	NOT AVAILABLE	NOT AVAILABLE	NOT AVAILABLE

**SPECIFICATIONS:**

**INSULATORS:** SHALL BE MANUFACTURED FROM A FIBERGLASS ROD WITH POLYMER WEATHER SHEDS. INSULATORS SHALL BE RATED AND TESTED IN ACCORDANCE WITH ANSI C29.11

**VERTICAL CLAMPTOPS** PART PER ANSI C29.7 AND GALVANIZED STEEL

**HORIZONTAL MOUNTING BASE** SHALL BE BENDABLE ALUMINUM OR GALVANIZED STEEL GAIN STYLE WITH (2) HOLES ON 12" CENTERS. THE TOP HOLE WILL BE .9375" DIAMETER AND THE BOTTOM HOLE WILL BE ELONGATED AND .9375" X 1.625"

UNITS FOR WHICH MANUFACTURER REQUIRES OR RECOMMENDS THE USE OF CORONA RINGS WILL NOT BE ACCEPTED

**PACKAGING AND MARKING:** EACH INSULATOR SHALL BE INDIVIDUALLY PACKAGED AND PERMANENTLY MARKED WITH THE MANUFACTURER'S NAME AND CATALOG NUMBER.



**INSULATOR, GUY  
FIBERGLASS**

Originator: DSmith

Date: 7/7/06

Approval: DSmith

Date: 7/5/2007

Page 1 of 1

Revision: **NEW**

Stds Committee Approval:  
**9/22/06**



**Application:** Fiberglass-reinforced, plastic guy insulators are used in the down guys and span guys of 15kV distribution lines to electrically insulate the guys.

**Specifications:**

**Dimensions:** Insulators shall have an insulated length of 12 inches.

**Electrical Ratings:** Minimum dry flashover shall be 140kV; minimum wet flashover shall be 70kV.

**Strength Ratings:** Insulators shall have a minimum breaking strength of either 15000 lbs or 30,000 lbs.

**Tests:** Insulators shall be tested electrically and mechanically per ANSI C29.1 as applicable. Test results shall be supplied upon request.

**Material:** Insulator shall be epoxy or polyester resin fiberglass with ultraviolet inhibitor. Color shall be light gray.

**Finish:** The insulator shall have a high gloss 2 mil minimum acrylic (aliphatic) urethane finish or equivalent to resist the adherence of contaminating materials, to minimize tracking and to prevent ultraviolet degradation.

**Fittings:** The unit shall be provided with end fittings which include guy wire rollers at each end capable of accepting 3/8" to 5/8" guy strand. End Fittings shall be pearlitic malleable iron casting per ASTM Specification A-220, or ductile iron casting per ASTM Specification A-536, latest revisions. Casting shall be hot dip galvanized per ASTM Specification A-153, latest revision.

**Packaging and Marking:** Items shall be suitably packaged to prevent damage in a container convenient for handling and storage. Manufacturer's name or symbol, catalog number and rated mechanical strength shall be on each part and its packaging. The month and year of manufacture shall be permanently stamped on the insulator.

**Approved Manufacturers**

PUD IDENTIFICATION		MANUFACTURER CATALOG NUMBER	
Stock Description	Stock No.	MacLean	Hughes
Insulator, Guy, Fiberglass, 15M#, 12"	021890	GCC15-12R2	CF692-12R2
Insulator, Guy, Fiberglass, 30M#, 12"	021895	GCC30-12R2	CF695-12-R2
Insulator, Guy, Fiberglass, 30M#, 36"	021900	GCC30-36R2	CF695-36R2
Insulator, Guy, Fiberglass, 30M#, 54"	021950	GCC30-54R2	CF695-54R2
Insulator, Guy, Fiberglass, 30M#, 96"	021960	GS3096R2	CF695-96R2



INSULATORS, PORCELAIN PIN

Originator: DSmith

Date: 6/27/2014

Approval: J. Mitchell

Date: 6/27/2014

Page 1 of 1

Revision: **Revised Mfg part number for 021550.**

Stds Committee Approval:  
**Approved**

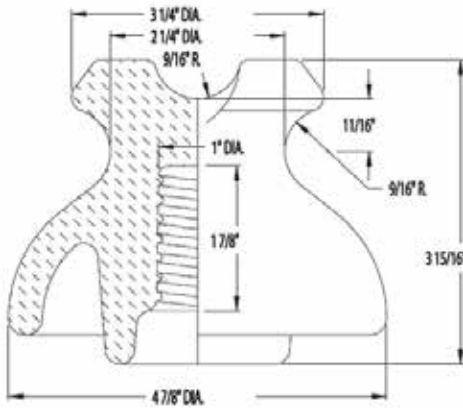

ANSI Class 55-3 "C" Neck

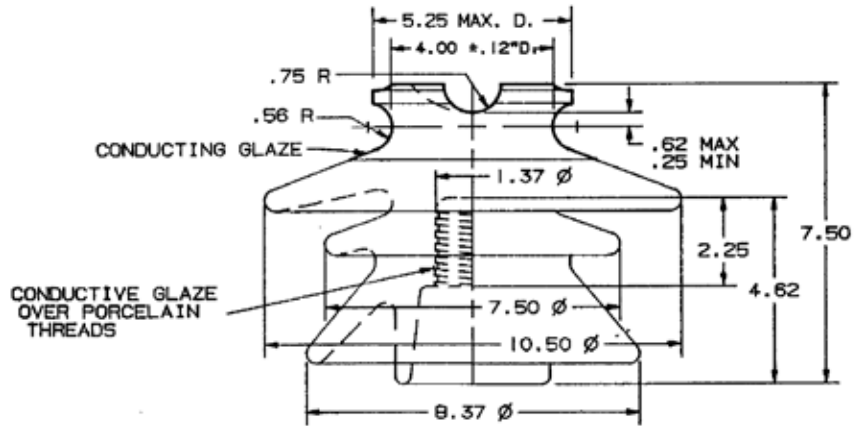

ANSI Class 55-3 "K" Neck

**Specification:**

**Pin-Type Porcelain Insulators** for low-and medium-voltage shall be of the configurations shown, and shall be made of good commercial-grade, wet-process porcelain in accordance with EEI-NEMA Standards TDJ-55, except as modified herein. Supplied with semi conductive glass to eliminate noise. Color as specified in description below.

**Reference Specifications:** EEI-NEMA TDJ-55, latest revision.

**Packaging & Marking:** Items shall be suitably packaged to prevent damage. The container shall be convenient for handling and storage. Manufacturer's name or symbol and catalog number shall be on each part and its packaging.

**Approved Manufacturers:**

PUD Identification	Item No.	Manufacturer Catalog Number		
		PPC Insulators	Lapp Insulators	Victor
INSULATORS, PIN, 11.5 KV WHITE PORCELAIN, ANSI CLASS 55-3, "C" Neck	021320	261S-W		
INSULATORS, PIN, 11.5 KV, GRAY PORCELAIN, ANSI CLASS 55-3, "C" Neck	021340	261S-MG	6184R-70	VI 605R
INSULATORS, PIN, 35 KV GRAY PORCELAIN, ANSI CLASS 56-3, "K" Neck	021550	2045-S	8190R-70	VI 611R



**INSULATORS, PORCELAIN  
SUBSTATION POST**

Originator: DSmith Date: 8/25/06

Approval: C. BOWMAN Date: 8/25/06

Revision: **NEW**

Stds Committee Approval:  
**9/22/06**

**ANSI T.R 205**

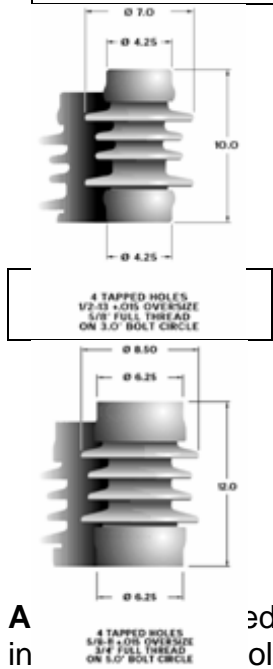

**A**  
in  
Switches & Substation  
Bus

**Specification:**

ANSI TECHNICAL REFERENCE	TR205	TR225
<b>Dimensions</b>		
Leakage Distance (in)	15.5	15.5
Height (in)	10	12
Strike distance (in)	6.8	6.7
Max Shed Diameter (in)	7.1	8.1
Top BCD (in)	3	5
Diameter Dt (in)	4.1	6.3
Bottom BCD (in)	3	5
Diameter Db (in)	4.1	6.3
<b>Mechanical Values</b>		
Cantilever Strength, Upright, Pounds	2000	4000
Cantilever Strength, Underhung, Pounds	2000	4000
Tensile Strength, Pounds	10000	20000
Torsion Strength, Inch-Pounds	11000	31000
Compression Strength, Pounds	50000	100000
<b>Electrical Values</b>		
BIL	110kV	110kV
Impulse Flashover, Positive, kV	125	125
Low Frequency Withstand, 10 Sec. Wet, kV	45	45
Impulse Withstand, kV	110	110
<b>Radio Influence Voltage Data</b>		
Test Voltage, Rms to Ground, kV	10	10
Maximum RIV, Microvolts at 1000kHz	50	50

**Packaging & Marking:**

Items shall be suitably packaged to prevent damage. The container shall be convenient for handling and storage. Manufacturer's name or symbol and catalog number shall be on each part and its packaging.

**Approved Manufacturers:**

PUD Identification	Manufacturer Catalog Number				
	Item No.	ANSI T.R.	PPC Insulators	Lapp Insulators	Victor
INSULATOR, POST, 10" HIGH, 15KV, GRAY (FOR BUS), 110KV BIL	021620	205	115951	315205-70	1751
INSULATOR, POST, 12" HIGH, 15KV, GRAY (FOR SWITCHES), 110KV BIL	021640	225	116231	315225-70	1767



**INSULATORS, DISTRIBUTION, SUSPENSION,  
DEAD-END, POLYMER**

Originator: DSmith

Date: 8/24/2007

Approval: DSmith

Date: 8/24/2007

Page 1 of 1

Revision: **NEW**

Stds Committee Approval:  
**Approved**

**Specification:** Composite suspension insulator shall comply with the latest revision of IEEE P1024 and meet the following requirements:

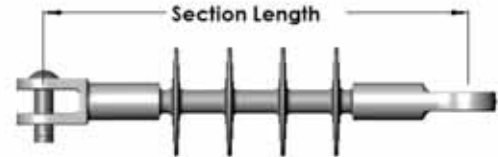

1. Weather Sheds: Non-tracking elastomer such as EPDM Rubber or Silicone.
2. Core: Fiberglass, polyester, or epoxy resin.
3. End Fittings: Aluminum alloy 356-T6 or galvanized malleable iron ASTM A47M
4. Grade 22010 coated per ASTM A-153 Class A.
5. Construction: The weather sheds shall be one piece molded type, fully bonded to the core. The end fitting/weather shed interface shall be sealed from moisture entry and free of voids. End fittings shall be attached to the core by swaging (compression).
6. Color: Shall be Sky Gray.
7. All ratings meet or exceed the requirements of ANSI C29.13 (2000) and LWIWG-01(96) Corrosion Resistant Boron Free Fiberglass Core / Silicone Housing / ANSI 52-4 Clevis & Tongue End Fittings.

Stock #	Line Voltage	Nominal Section Length (in)	Strength Class	Working Load	Dry Arc (in)	Leakage (in)	Dry Electrical Flashover (kV) 60 Hz	Wet Electrical Flashover (kV) 60 Hz	ANSI Class
21400	15kv	13	15K	7500	7.6	15	90	65	DS-15
21403	27kv	17	15K	7500	11.6	24.7	130	100	DS-28

**Approved Manufacturers**

PUD IDENTIFICATION		MANUFACTURER CATALOG NUMBER			
Stock Description	Stock No.	Salisbury	Hubbell	Volt TEK	MacLean
Insulator, Suspension Dead End Poly 15kv, 13", ANSI Class DS-15	021400	9501U-SI	401015-0215	1515-00	DS-15M
Insulator, Suspension Dead End Poly 27kv, 17", ANSI Class DS-28	021403	9502U-SI	401025-0215	2515-00	DS-28M

**Packaging & Marking:** Items shall be suitably packaged to prevent damage. The container shall be convenient for handling and storage. Manufacturer's name or symbol, catalog number, strength rating and date code shall be on each part or its packaging.

Every insulator in production runs shall be marked permanently and legibly in large, easily read figures with manufacturer's published routine proof tension load per ANSI C29.1.





**SPOOL INSULATOR - POLYMER**

Originator: DSmith

Date: 7/7/06

Approval: DSmith

Date: 7/7/06

Page 1 of 1

Revision: **NEW**

Stds Committee Approval:  
**Approved**



**Application:** Used for terminator secondary overhead conductor or neutrals. Direct replacement for existing porcelain insulators.

**Specification:** Each unit shall be molded from a UV-stable polymer and meet all requirements for ANSI 53-2 spool insulators. It will be compatible with all standard hardware installations; its shape shall be consistent with its porcelain counterpart.

**Packaging and Marking:** Items shall be suitably packaged to prevent damage. The container shall be convenient for handling and storage. Manufacturer's name or symbol and catalog number shall be on each part or (and) its packaging.

**Approved Manufacturers:**

PUD IDENTIFICATION		MANUFACTURER CATALOG NUMBER	
Stock Description	Stock No.	JOSLYN	HUBBELL
Insulator, Polymer, #2 Spool Only, Black, Use With 5/8" Bolt	021250	-	C9091032P



**INSULATOR, PORCELAIN GUY STRAIN**

Originator: DSmith

Date: 7/10/2006

Approval: DSmith

Date: 7/5/2007

Page 1 of 1

Revision: **NEW**

Stds Committee Approval:  
**APPROVED**



**Application:** The porcelain guy strain insulator is used to electrically insulate guy wires. This insulator is suitable for use in guying circuits to 15kV YG. For higher distribution voltages (24.9 and 34.5kV YG) this insulator must be doubled.

**Ordering Description:** (size) inches porcelain guy strain insulator, ANSI ( ) class, gray or skytone glaze with the following requirements:

**Material:** Guy strain insulators shall be fabricated from wet process porcelain per latest revision of ANSI C29.4.

**Packaging & Marking:** Items shall be suitably packaged to prevent damage. The container shall be convenient for handling and storage. Manufacturer's name or symbol and catalog number shall be on each part and its packaging.

Details	ANSI Class	Maximum Cable Diameter Inches	Ultimate Tensile Strength Lbs.	Max. Operating Load (Lbs.)	Low Frequency Flashover, kV	
					Dry	Wet
Size	54-2	1/2	12,000	6000	30	15

**Approved Manufacturers**

PUD IDENTIFICATION		MANUFACTURER CATALOG NUMBER				
Stock Description	Stock No.	Joslyn	Porc Prod	Lapp	Santana	Victor
INSLTR GUY PORC 4"L, 12K	021170	L504	504	8504-70	CA12014	504



**RIGID CLEVIS with INSULATOR  
Secondary & Grounding**

Originator: C. Rissman

Date: 7/7/06

Approval:

Date: 4/25/2008

Revision: **Revised Draft**

Stds Committee Approval:  
**Approved**

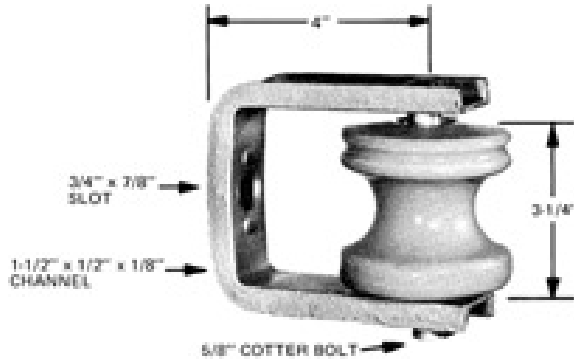

**Application:** This rigid clevis for spool insulator are used to deadend or support overhead services, secondaries and common neutrals. Mounting holes are slotted to permit installation without removing insulators.

**Packaging & Marking:** Items shall be suitably packaged to prevent damage. The container shall be convenient for handling and storage. Manufacturer's name or symbol and catalog number shall be on each part and its packaging.

**Approved Manufacturers:**

PUD IDENTIFICATION		MANUFACTURER CATALOG NUMBER		
Stock Description	Stock No.	MacLaen	Hubbell	Porc Prod
DEADEND, CLEVIS, RIGID, HD GALV 3/4" BOLT HOLE, WILL TAKE 3 1/4" DEADEND, SPOOL INSULATOR, NO SPOOL	027850	J93		



**INSULATOR, SERVICE KNOB – NYLON  
 Pin & Clamp Type**

Originator: DSmith

Date: 8/2/2006

Approval: DSmith

Date: 7/5/2007

Page 1 of 1

Revision: **NEW**

Stds Committee Approval:  
**Approved**

Pin Type

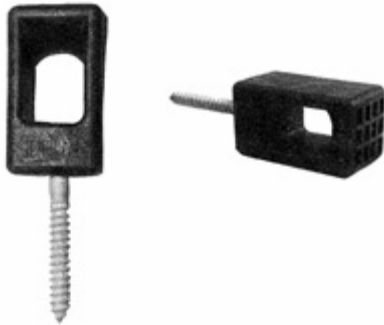

Clamp Type For  
 Service Mast

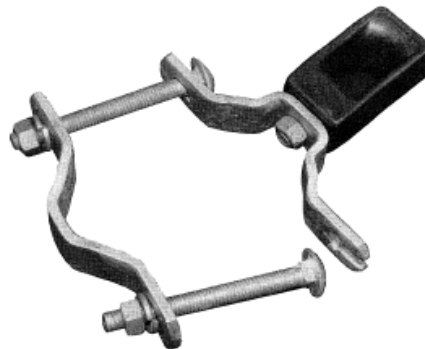

**Application:** Used to attached service wire to a wooden structure (Pin Type) or service mast. (Clamp type).

**Common Name:** House Knob or Mast Clamp

**Description:** Each unit shall be manufactured wireholders are manufactured from an engineered blend of nylon alloy reinforced with fibers to provide approximately twice the fracture strength as porcelain. The durable nylon alloy material shall be U.V. stabilized for extended service life in ultraviolet exposure.

The bracket design features an open slot which allows the bracket to be installed without disassembling the bolts. Accommodates a range of 1-1/4 through 3-inch diameter pipe. Insulator Color shall be Black.

**Packaging and Marking:** Items shall be suitably packaged to prevent damage. The container shall be convenient for handling and storage. Manufacturer's name or symbol and catalog number shall be on each part or (and) its packaging.

**Shipping:** Special Shipping Instructions

**Approved Manufacturers:**

PUD IDENTIFICATION		MANUFACTURER CATALOG NUMBER	
Stock Description	Stock No.	JOSLYN	Hubbell
INSULATOR, SERVICE KNOB, CLAMP TYPE - NYLON	020650	J0588Z	
INSULATOR, SERVICE KNOB, PIN TYPE - NYLON	021990	J0893Z	C2070139



# FASTENERS

Originator: DSmith

Date: 2/8/2007

Approval: DSmith

Date: 2/8/2007

Page 1 of 1

Revision: **NEW**

Stds Committee Approval:  
**Approved**



# FASTENERS





**CARRIAGE BOLTS**  
**Galvanized or Zinc Plated**

Originator: DSmith

Date: 7/7/06

Approval: DSmith

Date: 6/19/2007

Page 1 of 3

Revision: **NEW**

Stds Committee Approval:  
**Approved**



**Description:** Carriage bolts are roll threaded with square shoulder and square nut. Manufactured in accordance with ANSI standards.

**Finish:** Steel is zinc plated for moderate protection against rust

**Packaging and Marking:** Items shall be suitably packaged to prevent damage. The container shall be convenient for handling and storage. Manufacturer's name or symbol and catalog number shall be on each part or (and) its packaging.

**Approved Manufacturers MacLean/Joslyn, Hubbell Power Systems**

**Stock # Description**

145430	BOLT, CARRIAGE, 3/16" X 3/4", NC, GD 2, ZINC PLT,USE 10-24 NUTS FOR 3/16"
145431	BOLT, CARRIAGE, 3/16" X 1", NC, GD 2, ZINC PLT,USE 10- 24 NUTS FOR 3/16"
145432	BOLT, CARRIAGE, 3/16" X 1-1/4", NC, GD 2, ZINC PLT,USE 10-24 NUTS FOR 3/16"
145433	BOLT, CARRIAGE, 3/16" X 1-1/2", NC, GD 2, ZINC PLT,USE 10-24 NUTS FOR 3/16"
145435	BOLT, CARRIAGE, 3/16" X 2", NC, GD 2, ZINC PLT,USE 10- 24 NUTS FOR 3/16"
145437	BOLT, CARRIAGE, 3/16" X 2-1/2", NC, GD 2, ZINC PLT,USE 10-24 NUTS FOR 3/16"
145438	BOLT, CARRIAGE, 3/16" X 3", NC, GD 2, ZINC PLT,USE 10- 24 NUTS FOR 3/16"
145439	BOLT, CARRIAGE, 1/4" X 1/2", NC, GD 2, ZINC PLT
145440	BOLT, CARRIAGE, 1/4" X 3/4", NC, GD 2, ZINC PLT
145441	BOLT, CARRIAGE, 1/4" X 1", NC, GD 2, ZINC PLT
145442	BOLT, CARRIAGE, 1/4" X 1-1/4", NC, GD 2, ZINC PLT
145443	BOLT, CARRIAGE, 1/4" X 1-1/2", NC, GD 2, ZINC PLT
145444	BOLT, CARRIAGE, 1/4" X 1-3/4", NC, GD 2, ZINC PLT
145445	BOLT, CARRIAGE, 1/4" X 2", NC, GD 2, ZINC PLT
145446	BOLT, CARRIAGE, 1/4" X 2-1/4",NC, ZINC PLT
145447	BOLT, CARRIAGE, 1/4" X 2-1/2", NC, GD 2, ZINC PLT
145448	BOLT, CARRIAGE, 1/4" X 2-3/4", NC, GD 2, ZINC PLT
145449	BOLT, CARRIAGE, 1/4" X 3", NC, GD 2, ZINC PLT
145450	BOLT, CARRIAGE, 1/4" X 3-1/2", NC, GD 2, ZINC PLT
145451	BOLT, CARRIAGE, 1/4" X 4", NC, GD 2, ZINC PLT
145452	BOLT, CARRIAGE, 1/4" X 4-1/2", NC, GD 2, ZINC PLT
145453	BOLT, CARRIAGE, 1/4" X 5", NC, GD 2, ZINC PLT
145454	BOLT, CARRIAGE, 1/4" X 5-1/2", NC, GD 2, ZINC PLT
145455	BOLT, CARRIAGE, 5/16" X 3/4", NC, GD 2, ZINC PLT
145457	BOLT, CARRIAGE, 5/16" X 1", NC, GD 2, ZINC PLT
145458	BOLT, CARRIAGE, 5/16" X 1-1/4", NC, GD 2, ZINC PLT
145459	BOLT, CARRIAGE, 5/16" X 1-1/2", NC, GD 2, ZINC PLT
145460	BOLT, CARRIAGE, 5/16" X 1-3/4", NC, GD 2, ZINC PLT



**CARRIAGE BOLTS**  
**Galvanized or Zinc Plated**

Originator: DSmith

Date: 7/7/06

Approval: DSmith

Date: 6/19/2007

Page 2 of 3

Revision: **NEW**

Stds Committee Approval:  
**Approved**

145461	BOLT, CARRIAGE, 5/16" X 2", NC, GD 2, ZINC PLT
145462	BOLT, CARRIAGE, 5/16" X 2-1/4", NC, GD 2, ZINC PLT
145463	BOLT, CARRIAGE, 5/16" X 2-1/2", NC, GD 2, ZINC PLT
145464	BOLT, CARRIAGE, 5/16" X 3", NC, GD 2, ZINC PLT
145465	BOLT, CARRIAGE, 5/16" X 3-1/2", NC, GD 2, ZINC PLT
145466	BOLT, CARRIAGE, 5/16" X 4", NC, GD 2, ZINC PLT
145467	BOLT, CARRIAGE, 5/16" X 4-1/2", NC, GD 2, ZINC PLT
145468	BOLT, CARRIAGE, 5/16" X 5", NC, GD 2, ZINC PLT
145469	BOLT, CARRIAGE, 5/16" X 5-1/2", NC, GD 2, ZINC PLT
145470	BOLT, CARRIAGE, 5/16" X 6", NC, GD 2, ZINC PLT
145471	BOLT, CARRIAGE, 3/8" X 1", NC, GD 2, ZINC PLT
145472	BOLT, CARRIAGE, 3/8" X 1-1/4", NC, GD 2, ZINC PLT
145473	BOLT, CARRIAGE, 3/8" X 1-1/2", NC, GD 2, ZINC PLT
145474	BOLT, CARRIAGE, 3/8" X 1-3/4", NC, GD 2, ZINC PLT
145475	BOLT, CARRIAGE, 3/8" X 2", NC, GD 2, ZINC PLT
145476	BOLT, CARRIAGE, 3/8" X 2-1/4", NC, GD 2, ZINC PLT
145477	BOLT, CARRIAGE, 3/8" X 2-1/2", NC, GD 2, ZINC PLT
145478	BOLT, CARRIAGE, 3/8" X 2-3/4", NC, GD 2, ZINC PLT
145479	BOLT, CARRIAGE, 3/8" X 3", NC, GD 2, ZINC PLT
145480	BOLT, CARRIAGE, 3/8" X 3-1/2", NC, GD 2, ZINC PLT
145481	BOLT, CARRIAGE, 3/8" X 4", NC, GD 2, ZINC PLT
145482	BOLT, CARRIAGE, 3/8" X 4-1/2", NC, GD 2, ZINC PLT
145483	BOLT, CARRIAGE, 3/8" X 5", NC, GD 2, ZINC PLT
145484	BOLT, CARRIAGE, 3/8" X 5-1/2", NC, GD 2, ZINC PLT
145485	BOLT, CARRIAGE, 3/8" X 6", NC, GD 2, ZINC PLT
145486	BOLT, CARRIAGE, 3/8" X 7", NC, GD 2, ZINC PLT
145487	BOLT, CARRIAGE, 3/8" X 8", NC, GD 2, ZINC PLT
145488	BOLT, CARRIAGE, 7/16" X 1", NC, GD 2, ZINC PLT
145489	BOLT, CARRIAGE, 7/16" X 1-1/4", NC, GD 2, ZINC PLT
145490	BOLT, CARRIAGE, 7/16" X 1-1/2", NC, GD 2, ZINC PLT
145492	BOLT, CARRIAGE, 7/16" X 2", NC, GD 2, ZINC PLT
145494	BOLT, CARRIAGE, 7/16" X 2-1/2", NC, GD 2, ZINC PLT
145495	BOLT, CARRIAGE, 7/16" X 3", NC, GD 2, ZINC PLT
145496	BOLT, CARRIAGE, 7/16" X 3-1/2", NC, GD 2, ZINC PLT
145497	BOLT, CARRIAGE, 7/16" X 4", NC, GD 2, ZINC PLT
145498	BOLT, CARRIAGE, 7/16" X 5", NC, GD 2, ZINC PLT
145499	BOLT, CARRIAGE, 7/16" X 6", NC, GD 2, ZINC PLT
145500	BOLT, CARRIAGE, 1/2" X 1-1/2", NC, GD 2, ZINC PLT
145501	BOLT, CARRIAGE, 1/2" X 2", NC, GD 2, ZINC PLT
145502	BOLT, CARRIAGE, 1/2" X 2-1/2", NC, GD 2, ZINC PLT
145503	BOLT, CARRIAGE, 1/2" X 3", NC, GD 2, ZINC PLT
145504	BOLT, CARRIAGE, 1/2" X 3-1/2", NC, GD 2, ZINC PLT
145505	BOLT, CARRIAGE, 1/2" X 4", NC, GD 2, ZINC PLT
145506	BOLT, CARRIAGE, 1/2" X 4-1/2", NC, GD 2, ZINC PLT
145507	BOLT, CARRIAGE, 1/2" X 5", NC, GD 2, ZINC PLT
145508	BOLT, CARRIAGE, 1/2" X 6", NC, GD 2, ZINC PLT
145509	BOLT, CARRIAGE, 1/2" X 7", NC, GD 2, ZINC PLT
145510	BOLT, CARRIAGE, 1/2" X 7-1/2", NC, GD 2, ZINC PLT
145511	BOLT, CARRIAGE, 1/2" X 8", NC, GD 2, ZINC PLT





**CARRIAGE BOLTS**  
**Galvanized or Zinc Plated**

Originator: DSmith

Date: 7/7/06

Approval: DSmith

Date: 6/19/2007

Page 3 of 3

Revision: **NEW**

Stds Committee Approval:  
**Approved**

145512	BOLT, CARRIAGE, 5/8" X 1-1/2", NC, GD 2, ZINC PLT
145513	BOLT, CARRIAGE, 5/8" X 2", NC, GD 2, ZINC PLT
145514	BOLT, CARRIAGE, 5/8" X 2-1/2", NC, GD 2, ZINC PLT
145515	BOLT, CARRIAGE, 5/8" X 3", NC, GD 2, ZINC PLT
145516	BOLT, CARRIAGE, 5/8" X 3-1/2", NC, GD 2, ZINC PLT
145517	BOLT, CARRIAGE, 5/8" X 4", NC, GD 2, ZINC PLT
145518	BOLT, CARRIAGE, 5/8" X 4-1/2", NC, GD 2, ZINC PLT
145519	BOLT, CARRIAGE, 5/8" X 5", NC, GD 2, ZINC PLT
145520	BOLT, CARRIAGE, 5/8" X 6", NC, GD 2, ZINC PLT
145521	BOLT, CARRIAGE, 5/8" X 7", NC, GD 2, ZINC PLT
145522	BOLT, CARRIAGE, 5/8" X 8", NC, GD 2, ZINC PLT
145992	BOLT, CARRIAGE, 3/4 X 2-1/2, NC, GD 2, ZINC PLT
145993	BOLT, CARRIAGE, 3/4 X 3, NC, GD 2, ZINC PLT
145994	BOLT, CARRIAGE, 3/4 X 3-1/2, NC, GD 2, ZINC PLT
145995	BOLT, CARRIAGE, 3/4 X 4, NC, GD 2, ZINC PLT
145996	BOLT, CARRIAGE, 3/4 X 4-1/2, NC, GD 2, ZINC PLT
145997	BOLT, CARRIAGE, 3/4 X 5, NC, GD 2, ZINC PLT
145998	BOLT, CARRIAGE, 3/4 X 6, NC, GD 2, ZINC PLT
145999	BOLT, CARRIAGE, 3/4 X 7, NC, GD 2, ZINC PLT
146000	BOLT, CARRIAGE, 3/4 X 8, NC, GD 2, ZINC PLT
146239	BOLT, CARRIAGE, 3/8 X 7, HD, GALVANIZED, NC
146431	BOLT, EYE, 1" NC X 2-1/2", W/SHOULDER
146436	BOLT, CARRIAGE, 5/16" X 7", NC, GD 2, ZINC PLT.
165350	BOLT, CARRIAGE, 1/4" X 2", GALVANIZED
165351	BOLT, CARRIAGE, 1/4" X 2-1/4", NC, GALVANIZED
165352	BOLT, CARRIAGE, 3/8" X 2-1/2", NC, GALVANIZED
165443	BOLT, CARRIAGE, 5/16" - 18 X 8", GRADE 2, ZINC PLT
165444	BOLT, CARRIAGE, 3/8" X 3-1/4", NC
166161	BOLT, CARRIAGE, 1/4" X 7", NC, GD 2, ZINC PLATE
166669	CARRIAGE, 3/8" X 3/4", ZINC PLT. W/LOCK ING NUT, B-LINE CABLE TRAY



### BOLT, DOUBLE-ARMING with Four Square Nuts - Galvanized

Originator: DSmith

Date: 7/9/2007

Approval: J Mitchell

Date: 2/13/13

Page 1 of 1

Revision: **Added Item**

Stds Committee Approval: **Approved**

**Application:** Double arm bolts are used for mounting pole line hardware on wood crossarms.

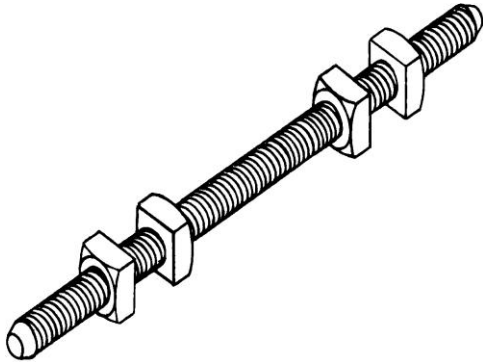

**Specification:** Double arm bolts and nuts shall conform to latest revision of ANSI B18.2.1 and ANSI C135.1.

**Bolts:** Bolt threads shall be machine rolled the full length of the bolt prior to galvanizing, and shall meet tolerances as specified per ANSI B1.1, Series UNC, Class 2B.

**Nuts:** Nut thread shall be tapped to meet tolerances as specified per ANSI B1.1, Series UNC, Class 2B.

**Material:** Hot rolled carbon steel bar per latest revision of ASTM A307

**Finish:** Double arm bolt shall be galvanized per ASTM A153.

**Packaging & Marking:** Items shall be suitably packaged to prevent damage. The container shall be convenient for handling and storage. Manufacturer's name or symbol and catalog number shall be on its packaging.

ITEM NUM	DESCRIPTION
010100	BOLT, DA, GALV, 1/2" X 26" W/ 4 SQ NUT
010120	BOLT, DA, GALV, 1/2" X 28" W/ 4 SQ NUT
010130	BOLT, DA, GALV, 1/2" X 30" W/ 4 SQ NUT
010132	BOLT, DA, GALV, 1/2" X 32" W/ 4 SQ NUT
010134	BOLT, DA, GALV, 1/2" X 34" W/ 4 SQ NUT
010050	BOLT, DA, GALV, 5/8" X 5" W/ 4 SQ NUT
010140	BOLT, DA, GALV, 5/8" X 14" W/ 4 SQ NUT
010160	BOLT, DA, GALV, 5/8" X 16" W/ 4 SQ NUT
010180	BOLT, DA, GALV, 5/8" X 18" W/ 4 SQ NUT
010200	BOLT, DA, GALV, 5/8" X 20" W/ 4 SQ NUT
010220	BOLT, DA, GALV, 5/8" X 22" W/ 4 SQ NUT
010220	BOLT, DA, GALV, 5/8" X 22" W/ 4 SQ NUT
010240	BOLT, DA, GALV, 5/8" X 24" W/ 4 SQ NUT
010260	BOLT, DA, GALV, 5/8" X 26" W/ 4 SQ NUT
010260	BOLT, DA, GALV, 5/8" X 26" W/ 4 SQ NUT
010280	BOLT, DA, GALV, 5/8" X 28" W/ 4 SQ NUT
010300	BOLT, DA, GALV, 5/8" X 30" W/ 4 SQ NUT
010300	BOLT, DA, GALV, 5/8" X 30" W/ 4 SQ NUT
010302	BOLT, DA, GALV, 5/8" X 32" W/ 4 SQ NUT
010304	BOLT, DA, GALV, 5/8" X 34" W/ 4 SQ NUT

ITEM NUM	DESCRIPTION
010360	BOLT, DA, GALV, 5/8" X 36" W/ 4 SQ NUT
010440	BOLT, DA, GALV, 3/4" X 14" W/ 4 SQ NUT
010442	BOLT, DA, GALV, 3/4" X 16" W/ 4 SQ NUT
010444	BOLT, DA, GALV, 3/4" X 18" W/ 4 SQ NUT
010446	BOLT, DA, GALV, 3/4" X 20" W/ 4 SQ NUT
010520	BOLT, DA, GALV, 3/4" X 22" W/ 4 SQ NUT
010540	BOLT, DA, GALV, 3/4" X 24" W/ 4 SQ NUT
010560	BOLT, DA, GALV, 3/4" X 26" W/ 4 SQ NUT
010580	BOLT, DA, GALV, 3/4" X 28" W/ 4 SQ NUT
010600	BOLT, DA, GALV, 3/4" X 30" W/ 4 SQ NUT
010602	BOLT, DA, GALV, 3/4" X 32" W/ 4 SQ NUT
010604	BOLT, DA, GALV, 3/4" X 34" W/ 4 SQ NUT
010660	BOLT, DA, GALV, 3/4" X 36" W/ 4 SQ NUT
010660	BOLT, DA, GALV, 3/4" X 36" W/ 4 SQ NUT



**EYE BOLT, Plain /Thimble  
with Square Nut  
GALVANIZED**

Originator: DSmith

Date: 7/13/2006

Approval: DSmith

Date: 6/19/2007

Page 1 of 1

Revision: **NEW**

Stds Committee Approval:  
**Approved**

**Application:** Eye bolts are used for mounting pole line hardware on wood structures.

**Specification:** Eye bolts and nuts shall conform to latest revisions of ANSI B18.2.1, B18.2.2, C135.4

**Bolts:** Bolt threads shall be machine rolled prior to galvanizing, and shall meet tolerances as specified per ANSI B1.1 series UNC, Class 2B. Minimum thread length shall be 4 inches on 6, 8 and 10 inch bolts, 6 inches rolled threads on all other lengths.

**Nuts:** Nut thread shall be tapped to meet tolerances as specified per ANSI B1.1, series UNC, Class 2B.

**Material:** Hot rolled carbon steel bar per latest revision of ASTM A307.

**Finish:** Eye bolt shall be galvanized per ASTM A153.

**Strength:** minimum tensile strength shall be 12,400 lbs.

**Packaging & Marking:** Items shall be suitably packaged to prevent damage. The container shall be convenient for handling and storage. Manufacturer's name or symbol and catalog number shall be on each bolt or its packaging.

**Approved Manufacturers: Hubbel, Joslyn**

Thimble Eye

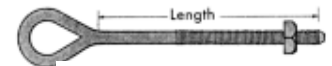

Plain Eye

ITEMNUM	DESCRIPTION
011460	BOLT, EYE PLAIN, GALV, 5/8" X 6" W/ SQ NUT
011480	BOLT, EYE PLAIN, GALV, 5/8" X 8" W/ SQ NUT
011500	BOLT, EYE PLAIN, GALV, 5/8" X 10" W/ SQ NUT
011520	BOLT, EYE PLAIN, GALV, 5/8" X 12" W/ SQ NUT
011520	BOLT, EYE PLAIN, GALV, 5/8" X 12" W/ SQ NUT
011540	BOLT, EYE PLAIN, GALV, 5/8" X 14" W/ SQ NUT
011560	BOLT, EYE PLAIN, GALV, 5/8" X 16" W/ SQ NUT
011580	BOLT, EYE PLAIN, GALV, 5/8" X 18" W/ SQ NUT
011600	BOLT, EYE PLAIN, GALV, 5/8" X 20" W/ SQ NUT
011640	BOLT, EYE PLAIN, GALV, 5/8" X 24" W/ SQ NUT
011660	BOLT, EYE PLAIN, GALV, 5/8" X 26" W/ SQ NUT
011700	BOLT, EYE PLAIN, GALV, 5/8" X 30" W/ SQ NUT
011750	BOLT, EYE PLAIN, GALV, 3/4" X 12" W/ SQ NUT
011770	BOLT, EYE PLAIN, GALV, 3/4" X 14" W/ SQ NUT
011790	BOLT, EYE PLAIN, GALV, 3/4" X 16" W/ SQ NUT
011810	BOLT, EYE PLAIN, GALV, 3/4" X 18" W/ SQ NUT
011910	BOLT, THIMBLE EYE, STRAIGHT, 5/8" X 12", HD GALV W/SQ NUT
011930	BOLT, THIMBLE EYE, STRAIGHT, 5/8" X 14", HD GALV W/SQ NUT
011970	BOLT, THIMBLE EYE, STRAIGHT, 5/8" X 18", HD GALV W/SQ NUT
011990	BOLT, THIMBLE EYE, STRAIGHT, 3/4" X 14", HD GALV W/SQ NUT



**BOLT, MACHINE  
SQUARE HEAD With NUT  
Galvanized**

Originator: DSmith

Date: 7/9/2007

Approval: J Mitchell

Date: 1/17/2013

Revision: **Added vendor**

Stds Committee Approval:  
**Approved**



**Application:** Machine bolts are used for mounting pole line hardware on wood structures.

**Specifications:** Machine bolts and nuts shall conform to latest revision of ANSI B18.2.1, B18.2.2, ANSI C135.1.

**Bolts:** Bolt threads shall be machine rolled prior to galvanizing, and shall meet tolerances as specified per ANSI B1.1 series UNC, Class 2B. Minimum thread length shall be 3 inches on 3 1/2", 4", 4 1/2", 5", and 6" bolts, and 6 inches on all longer lengths.

**Nuts:** Thread shall be tapped to meet tolerances as specified per ANSI B1.1, Series UNC, Class 2B.

**Material:** Hot rolled carbon steel bar per latest revision of ASTM A307.

**Finish:** Machine bolt shall be galvanized per ASTM A153.

**Strength:** Minimum tensile strength shall be SAE2 7,800 lbs.

**Packaging & Marking:** Items shall be suitably packaged to prevent damage. The container shall be convenient for handling and storage. Manufacturer's name or symbol and catalog number shall be on its packaging.

**Approved Manufacturers: Joslyn, Hubbell, & Allied**

ITEM NUM	DESCRIPTION
008520	BOLT, MACH SQ HEAD, GALV, 1/2" X 1 1/2" W/ SQ NUT
008540	BOLT, MACH SQ HEAD, GALV, 1/2" X 2" W/ SQ NUT
008560	BOLT, MACH SQ HEAD, GALV, 1/2" X 2-1/2" W/ SQ NUT
008580	BOLT, MACH SQ HEAD, GALV, 1/2" X 3" W/ SQ NUT
008600	BOLT, MACH SQ HEAD, GALV, 1/2" X 3 1/2" W/ SQ NUT
008620	BOLT, MACH SQ HEAD, GALV, 1/2" X 4" W/ SQ NUT
008640	BOLT, MACH SQ HEAD, GALV, 1/2" X 4 1/2" W/ SQ NUT
008660	BOLT, MACH SQ HEAD, GALV, 1/2" X 5" W/ SQ NUT
008700	BOLT, MACH SQ HEAD, GALV, 1/2" X 6" W/ SQ NUT
008740	BOLT, MACH SQ HEAD, GALV, 1/2" X 7" W/ SQ NUT
008780	BOLT, MACH SQ HEAD, GALV, 1/2" X 8" W/ SQ NUT
008820	BOLT, MACH SQ HEAD, GALV, 1/2" X 9" W/ SQ NUT
008860	BOLT, MACH SQ HEAD, GALV, 1/2" X 10" W/ SQ NUT
008940	BOLT, MACH SQ HEAD, GALV, 1/2" X 12" W/ SQ NUT
009020	BOLT, MACH SQ HEAD, GALV, 1/2" X 14" W/ SQ NUT
009040	BOLT, MACH SQ HEAD, GALV, 1/2" X 16" W/ SQ NUT
009060	BOLT, MACH SQ HEAD, GALV, 1/2" X 18" W/ SQ NUT
009080	BOLT, MACH SQ HEAD, GALV, 1/2" X 20" W/ SQ NUT



**BOLT, MACHINE  
SQUARE HEAD With NUT  
Galvanized**

Originator: DSmith

Date: 7/9/2007

Approval: J Mitchell

Date: 1/17/2013

Revision: **Added vendor**

Stds Committee Approval:  
**Approved**

ITEM NUM	DESCRIPTION
009270	BOLT, MACH SQ HEAD, GALV, 5/8" X 1 1/2" W/ SQ NUT
009290	BOLT, MACH SQ HEAD, GALV, 5/8" X 2" W/ SQ NUT
009350	BOLT, MACH SQ HEAD, GALV, 5/8" X 5" W/ SQ NUT
009360	BOLT, MACH SQ HEAD, GALV, 5/8" X 6" W/ SQ NUT
009370	BOLT, MACH SQ HEAD, GALV, 5/8" X 7" W/ SQ NUT
009380	BOLT, MACH SQ HEAD, GALV, 5/8" X 8" W/ SQ NUT
009400	BOLT, MACH SQ HEAD, GALV, 5/8" X 10" W/ SQ NUT
009420	BOLT, MACH SQ HEAD, GALV, 5/8" X 12" W/ SQ NUT
009440	BOLT, MACH SQ HEAD, GALV, 5/8" X 14" W/ SQ NUT
009460	BOLT, MACH SQ HEAD, GALV, 5/8" X 16" W/ SQ NUT
009480	BOLT, MACH SQ HEAD, GALV, 5/8" X 18" W/ SQ NUT
009500	BOLT, MACH SQ HEAD, GALV, 5/8" X 20" W/ SQ NUT
009500	BOLT, MACH SQ HEAD, GALV, 5/8" X 20" W/ SQ NUT
009520	BOLT, MACH SQ HEAD, GALV, 5/8" X 22" W/ SQ NUT
009540	BOLT, MACH SQ HEAD, GALV, 5/8" X 24" W/ SQ NUT
009540	BOLT, MACH SQ HEAD, GALV, 5/8" X 24" W/ SQ NUT
009560	BOLT, MACH SQ HEAD, GALV, 5/8" X 26" W/ SQ NUT
009580	BOLT, MACH SQ HEAD, GALV, 5/8" X 28" W/ SQ NUT
009600	BOLT, MACH SQ HEAD, GALV, 5/8" X 30" W/ SQ NUT
009620	BOLT, MACH SQ HEAD, GALV, 5/8" X 32" W/ SQ NUT
009640	BOLT, MACH SQ HEAD, GALV, 5/8" X 34" W/ SQ NUT
009660	BOLT, MACH SQ HEAD, GALV, 5/8" X 36" W/ SQ NUT
009700	BOLT, MACH SQ HEAD, GALV, 3/4" X 10" W/ SQ NUT
009720	BOLT, MACH SQ HEAD, GALV, 3/4" X 12" W/ SQ NUT
009740	BOLT, MACH SQ HEAD, GALV, 3/4" X 14" W/ SQ NUT
009760	BOLT, MACH SQ HEAD, GALV, 3/4" X 16" W/ SQ NUT
009780	BOLT, MACH SQ HEAD, GALV, 3/4" X 18" W/ SQ NUT
009800	BOLT, MACH SQ HEAD, GALV, 3/4" X 20" W/ SQ NUT
009820	BOLT, MACH SQ HEAD, GALV, 3/4" X 22" W/ SQ NUT
009840	BOLT, MACH SQ HEAD, GALV, 3/4" X 24" W/ SQ NUT
009840	BOLT, MACH SQ HEAD, GALV, 3/4" X 24" W/ SQ NUT
009860	BOLT, MACH SQ HEAD, GALV, 3/4" X 26" W/ SQ NUT
009880	BOLT, MACH SQ HEAD, GALV, 3/4" X 28" W/ SQ NUT
009900	BOLT, MACH SQ HEAD, GALV, 3/4" X 30" W/ SQ NUT
082420	BOLT, MACH SQ HEAD, GALV, 7/8" X 2" W/ SQ NUT
082420	BOLT, MACH SQ HEAD, GALV, 7/8" X 2" W/ SQ NUT
082440	BOLT, MACH SQ HEAD, GALV, 7/8" X 4" W/ SQ NUT

CHELAN COUNTY  
**PUBLIC UTILITY DISTRICT**  
*Owned By The People We Serve*



**BOLT, MACHINE  
SQUARE HEAD With NUT  
Galvanized**

Originator: DSmith

Date: 7/9/2007

Approval: J Mitchell

Date: 1/17/2013

Revision: **Added vendor**

Stds Committee Approval:  
**Approved**

ITEM NUM	DESCRIPTION
082450	BOLT, MACH SQ HEAD, GALV, 7/8" X 10" W/ SQ NUT
082520	BOLT, MACH SQ HEAD, GALV, 7/8" X 12" W/ SQ NUT
082540	BOLT, MACH SQ HEAD, GALV, 7/8" X 14" W/ SQ NUT
082560	BOLT, MACH SQ HEAD, GALV, 7/8" X 16" W/ SQ NUT
082560	BOLT, MACH SQ HEAD, GALV, 7/8" X 16" W/ SQ NUT
082580	BOLT, MACH SQ HEAD, GALV, 7/8" X 18" W/ SQ NUT
082600	BOLT, MACH SQ HEAD, GALV, 7/8" X 20" W/ SQ NUT
082620	BOLT, MACH SQ HEAD, GALV, 7/8" X 22" W/ SQ NUT
082640	BOLT, MACH SQ HEAD, GALV, 7/8" X 24" W/ SQ NUT
082640	BOLT, MACH SQ HEAD, GALV, 7/8" X 24" W/ SQ NUT
082660	BOLT, MACH SQ HEAD, GALV, 7/8" X 26" W/ SQ NUT
082680	BOLT, MACH SQ HEAD, GALV, 7/8" X 28" W/ SQ NUT
082700	BOLT, MACH SQ HEAD, GALV, 7/8" X 30" W/ SQ NUT
082702	BOLT, MACH SQ HEAD, GALV, 7/8" X 32" W/ SQ NUT
082704	BOLT, MACH SQ HEAD, GALV, 7/8" X 34" W/ SQ NUT
082706	BOLT, MACH SQ HEAD, GALV, 7/8" X 36" W/ SQ NUT





**SINGLE UPSET BOLT**

Originator: DSmith

Date: 11/3/2014

Approval: J Mitchell

Date: 11/03/2014

Page 1 of 1

Revision: **Update catalog numbers**

Stds Committee Approval:  
**Approved**



**Application:** Single upset bolt is used to support spool insulator on wood structures.

**Ordering Description:** 5/8" x ( ) single upset bolt. Upset bolt shall be supplied with one round washer and two nuts and cotter key. Upset bolt and nuts shall conform to ANSI B18.2.1, B18.2.2, ANSI C135.31 (latest revision).

Bolt: Bolt shall have 4 inches of thread. Threads shall be machine rolled prior to galvanizing. Bolt shall meet tolerances as specified per ANSI B1.1 Series UNC, Class 2B.

Nut: Threads shall be tapped to meet tolerances as specified per ANSI B1.1, Series UNC, Class 2B.

Cotter Key: Shall be commercial grade brass, bronze, or stainless steel and be self-locking.

Material: Hot rolled carbon steel bar per latest revision of ASTM A307.

Finish: Upset bolt shall be galvanized per latest revision of ASTM A153.

Strength: Minimum tensile strength shall be 12,400 lbs.

**Packaging & Marking:** Items shall be suitably packaged to prevent damage. The container shall be convenient for handling and storage. Manufacturer's name or symbol and catalog number shall be on its packaging.

**Approved Manufacturers**

PUD Identification	Stock No.	Manufacturer Catalog Number	
		Hubbell	MacLean
BOLT, INSUL, SGL UPSET 5/8"x10"	011250	7742	J2344-1/2
BOLT, INSUL, SGL UPSET 5/8"x12"	011270	7743	J2346-1/2
BOLT, INSUL, SGL UPSET 5/8"x14"	011290	7744	J2348-1/2





**NUT, EYE, GALVANIZED**

Originator: DSmith

Date: 7/7/06

Approval: DSmith

Date: 6/19/2007

Page 1 of 1

Revision: **NEW**

Stds Committee Approval:  
**Approved**



**Application:** Eye nuts are used for attaching deadend clamps for primary, secondary, service and neutral conductors on double arming bolts.

**Specifications:**

Threads: Shall be tapped to meet tolerances as specified per ANSI B1.1 Series UNC, Class 2B.

Material: Shall be forged steel per ASTM A-576 (latest revision).

Finish: Shall be hot dipped galvanized per ASTM A-153 (latest revision).

Strength: Shall be 12,500 pounds.

**Packaging & Marking:** Items shall be suitably packaged to prevent damage. The container shall be convenient for handling and storage. Manufacturer's name or symbol and catalog number shall be on each part and its packaging.

**Approved Manufacturers: HUBBELL, JOSLYN, HUGHES**

Stock No.	Stock Description
024900	NUT, OVAL EYE (PLAIN), 5/8" HD GALV
024920	NUT, OVAL EYE (PLAIN), 3/4" HD GALV
060047	NUT, OVAL EYE (PLAIN), 7/8" HD GALV



**LAG SCREWS**

Originator: DSmith

Date: 7/13/2006

Approval: DSmith

Date: 7/27/2007

Page 1 of 1

Revision: **NEW**

Stds Committee Approval:  
**Approved**

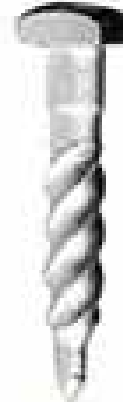
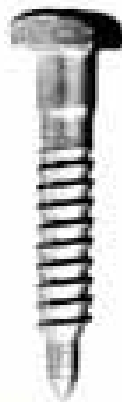
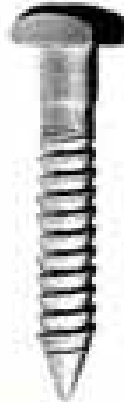
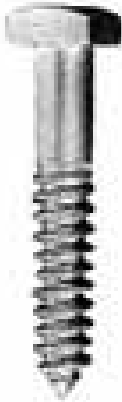

GIMLET POINT    FETTER DRIVE REGULAR POINT    FETTER DRIVE DRIVE POINT    TWIST DRIVE DRIVE POINT

**Application:** Lag screws are used to mount pole line hardware on wood structures.

**Specifications:** Lag screws with upset shoulder for tighter fit. Hot dip galvanized.

**Packaging & Marking:** Items shall be suitably packaged to prevent damage. The container shall be convenient for handling and storage. Manufacturer's name or symbol and catalog number shall be on its packaging.

PUD IDENTIFICATION		MANUFACTURER CATALOG NUMBER		
Stock Number	Stock Description	Hubbell	MacLean	
028500	SCREW, LAG 1/2" X 4", (MINIMUM THREAD LENGTH 2 5/8") HD GALV TWIST DRIVE POINT, Square Head	508500	J8754TP	
028510	SCREW, LAG 1/2" X 5", Fetter Drive Pilot-Point Lag Screw	508755		



**TEK SCREWS, SELF-TAPPING**

Originator: DSmith

Date: 7/9/2007

Approval: DSmith

Date: 6/19/2007

Page 1 of 1

Revision: **NEW**

Stds Committee Approval:  
**Approved**



**Application:** These screws are used for attaching location ID nameplates to equipment.

**Specifications:**

**Packaging & Marking:** Each roll shall be on a core of not less than one inch inside diameter, and enclosed in an individual container. The core shall be marked with the manufacturer's name or trademark and type of tape. Each roll-container shall be marked with the core information plus width and length of the tape and date of manufacture.

PUD IDENTIFICATION		Manufacturer Catalog Number	
Item Number	Description	FASTENERS	
028498	SCREW, TEK SELF TAPPING, (8-18X5/8"), Box of 100	1305.0818.0062.20	



**WASHER, BELLEVILLE, STAINLESS STEEL**

Originator: DSmith

Date: 7/12/2006

Approval: DSmith

Date: 6/19/2007

Page 1 of 1

Revision: **NEW**

Stds Committee Approval:

**Approved**



**Application:** A **Belleville washer**, also known as a cupped spring washer, is a type of non-flat washer. It has a slight conical shape which gives the washer a spring characteristic. Belleville washers are typically used as springs, or to apply a pre-load or flexible quality to a bolted joint.

**Approved Manufacturers**

PUD IDENTIFICATION		MANUFACTURER CATALOG NUMBER	
Stock No	Stock Description	Mt. Hood	Beaver
007084	Washer, Belleville, SS, 5/8", 1.34 Od., .644 Id., .078 H		
034054	Washer, Belleville, 1/2", Stainless Steel, Outside Dia, 1", Hole Dia, 5/8"	K1063-E-100-S	BY DESCRIPTION
147794	Washer 1/4" Belleville SS		
160216	Washer 1/2" Belleville SS		



**WASHER, DOUBLE COIL SPRING, GLAVANIZED**

Originator: DSmith

Date: 7/7/06

Approval: DSmith

Date: 6/19/2007

Page 1 of 1

Revision: **NEW**

Stds Committee Approval:  
**Approved**



**Application:** Coil Spring washers are used to keep hardware tight as wood dries.

**Specifications:**

Material: Washers shall be made of Class A carbon steel of rectangular cross section.

Finish: Washers shall be galvanized per ASTM A123 and A153.

**Packaging & Marking:** Items shall be suitably packaged to prevent damage. The container shall be convenient for handling and storage. Manufacturer's name or symbol and catalog number shall be on each part or its packaging.

PUD IDENTIFICATION		MANUFACTURER CATALOG NUMBER		
ITEMNUM	DESCRIPTION	JOSYLN	HUBBELL	HUGHES
034040	WASHER, DOUBLE COIL, 3/8", SPRING LOCK, HD GALV	J-175	C205-0188	SLW2-30
034055	WASHER, DOUBLE COIL, 1/2", SPRING LOCK, HD GALV	J-176	C205-0185	SLW2-50
034062	WASHER, DOUBLE COIL, 5/8", SPRING LOCK, HD GALV	J-177	C205-0186	SLW2-60
034067	WASHER, DOUBLE COIL, 3/4", SPRING LOCK, HD GALV	J-178	C205-0187	SLW2-70
088330	WASHER, DOUBLE COIL, 7/8", SPRING LOCK, HD GALV			SLW-2-80



**WASHERS, SQUARE, FLAT AND CURVED**

Originator: DSmith

Date: 7/7/06

Approval: DSmith

Date: 6/19/2007

Page 1 of 1

Revision: **NEW**

Stds Committee Approval:  
**Approved**

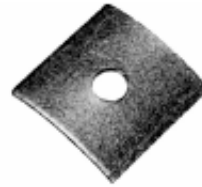

**Application:** The flat and curved square washers are placed against wood surfaces when mounting hardware on wood structures.

**Specifications:**

Material: Washer shall be fabricated from hot or cold rolled steel, with a maximum carbon content of 0.33%, and be free of rough or uneven surfaces and edges.

Finish: Hot-dip galvanized per latest revision of ASTM A-153.

**Packaging & Marking:** Items shall be suitably packaged to prevent damage. The container shall be convenient for handling and storage. Manufacturer's name or symbol and catalog number shall be on its packaging.

PUD IDENTIFICATION		MANUFACTURER CATALOG NUMBER		
Stock No.	Stock Description	Joslyn	Hughes	Hubbell
034000	WASHER, SQUARE FLAT, 5/8, HD GALV, 2 1/4" X 2 1/4" X 3/16"	J1075	-----	6813
034020	WASHER, SQUARE FLAT, 3/4", HD GALV, 3" X 3" X 3/16"	J1078	-----	6816
034030	WASHER, SQUARE FLAT, 7/8", HD GALV, 4" X 4" X 1/4"	----	SW4-80	6819
034090	WASHER, SQUARE CURVED, 3/4", HD GALV, 3" X 3" X 1/4"	J6823	-----	6822-1/2
034100	WASHER, SQUARE CURVED, 7/8", HD GALV 4" X 4" X 1/4"	J6829	SCW4-80	-----
165328	WASHER,FLAT,5/8",SQ. BEVELED,GALVANIZED	----- -	-----	-----



**Staples, Wire**

Originator: DSmith

Date:6/19/2007

Approval: DSmith

Date: :6/19/2007

Page 1 of 1

Revision: **NEW**

Stds Committee Approval:  
**Approved**



**Application**

Wire staples are used to attach ground wire to wooden poles.

**Specifications:** All staples and finishes must meet or exceed the following Standards.

- Federal Specifications FF-N-105A, type 111, style 1
- ANSI standards for rolled or Slashed points
- EEI-NEMA standards for rolled or slashed points with serrated edge

**Packaging & Marking:**

Items shall be suitably packaged to prevent damage. The container shall be convenient for handling and storage. Manufacturer's name or symbol and catalog number shall be on its packaging.

PUD IDENTIFICATION		Manufacturer Catalog Number	
Item Number	Description	L & J Industrial Staples	
031900	STAPLE,GALV, 1 3/4"X3/8"X 0.148" - SERRATED POINT	J7487HDG	
031905	STAPLE, WIRE, GALV, (2 1/2" WIDE X 4" LONG)		





**TAPE**  
**Vinyl Or Rubber**

Originator: DSmith

Date: 7/9/2007

Approval: DSmith

Date: 6/19/2007

Page 1 of 2

Revision: **NEW**

Stds Committee Approval:

**Approved**

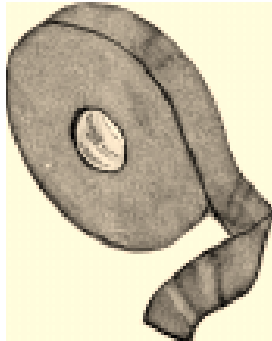

**Application:** This tape is used to insulate low voltage electrical wires and connections. The tape is to be used for most installations including cold weather (0 deg. F) applications.

**Specifications:** Black, all-weather, polyvinyl chloride plastic insulating tape with a rubber based pressure-sensitive adhesive. Tape shall meet the electrical, physical and test requirements of ANSI/UL 510, CSA-22.2, ASTM D150, and ASTM D1000 latest

revisions.

**Packaging & Marking:** Each roll shall be on a core of not less than one inch inside diameter, and enclosed in an individual container. The core shall be marked with the manufacturer's name or trademark and type of tape. Each roll-container shall be marked with the core information plus width and length of the tape and date of manufacture.

PUD IDENTIFICATION		MANUFACTURER CATALOG NUMBER	
Stock No.	Stock Description	3M	Plymouth
032757	TAPE, RED MARKING, 1/2" X 20'	UPC 1022435 COLOR CODING.35 RED	
032758	TAPE, WHITE MARKING, 1/2"X20'	UPC 1023235 COLOR CODING.35 WHITE	
032759	TAPE, BLUE MARKING, 1/2" X 20'	UPC 1024035 COLOR CODING.35 BLUE	
032760	TAPE, ORANGE MARKING, 1/2" X 20'	UPC 1027335 COLOR CODING.35 ORANGE	
032761	TAPE 1/2" X 20' 3M PHASING YELLOW	UPC 1025735 COLOR CODING.35 YELLOW	
032762	TAPE 1/2" X 20' 3M PHASING BROWN	UPC 1029935 COLOR CODING.35 BROWN UPC 10299	
032763	TAPE 1/2" X 20' 3M PHASING GREEN	3M ELECTRICAL PRODUCTS DIVISION3-M (MINN. MINEING & MFGING) UPC 1026535 SCOTCH BRAND 3M VINYL ELECTRICAL TAPE FORCOLOR CODING.35 GREEN UPC 10265 1/2" X 20' (6.6 YDS.)INNER UNIT PACK 10/CTN PACKAGING 100/CASE	



**TAPE**  
**Vinyl Or Rubber**

Originator: DSmith

Date: 7/9/2007

Approval: DSmith

Date: 6/19/2007

Page 2 of 2

Revision: **NEW**

Stds Committee Approval:  
**Approved**

Stock No.	Stock Description	3M	Plymouth
032764	TAPE, GRAY MARKING, 1/2" X 20'	3M ELECTRICAL PRODUCTS DIVISION3-M (MINN. MINEING & MFGING) UPC 1028135 SCOTCH BRAND 3M VINYL ELECTRICAL TAPE FORCOLOR CODING.35 GRAY UPC 10281 1/2" X 20' (6.6 YDS.)INNER UNIT PACK 10/CTN PACKAGING 100/CASE	
032800	TAPE, BLACK VINYL, PREMIUM 85CW, 1.5" CORE, 3/4" X 66'	37	4243
032820	TAPE, 1 1/2" VINYL, PREMIUM 85CW, 1.5 CORE, 108' LONG	37	4273
032830	TAPE BUS BAR INSULATING SUB.	RAYCHEM #HVBT-2-R	
049520	TAPE CU SHIELDING 3M24	G.E. #3M-24	
049620	TAPE, WARNING (4 MILS) 6" WIDE- 1000' LONG- RED WITH BLACK - INSCRIBED WITH "CHELAN COUNTY POWER" AND TELEPHONE(509) 663-8121. MUST BE IN DISPENSER BOXES.	TERRATAPE (REEF INDUSTRIES, HOUSTON, TX ALLEN SYSTEMS THOR ENTERPRISES, INC.(TAPE ITEM NUMBER 22002 AND DISPENSER NUMBER 49005)	
143002	TAPE,DUCT,SILVER,2" X 60 YDS.	P	
143002	TAPE,DUCT,SILVER,2" X 60 YDS.	NASHUA 357 SURE TAPE PC622 UNITED TAPE COMPANY #110-2 3M "SCOTCH" BRAND 50254 3-M (MINN. MINEING & MFGING) 50254	
148863	TAPE,SPLICING,RUBBER,LINERLESS,1" X 30'	3-M (MINN. MINEING & MFGING) 130C	
160312	TAPE, FLAGGING, ENGINEER, 1 3/16" X 150 FEET, GLOW ORANGE,SURVEY		



**NYLON TIE CABLES**

Originator: DSmith

Date: 7/7/06

Approval: DSmith

Date: 6/19/2007

Page 1 of 1

Revision: **NEW**

Std's Committee Approval:  
**Approved**

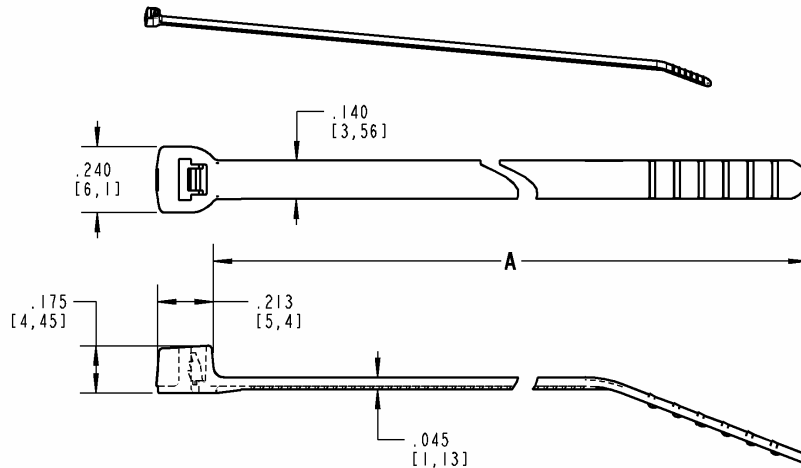

**Application:** fastening, bundling, clamping and managing wires.

**Common Name:** Zip Tie

**Approved Manufacturers:**

PUD IDENTIFICATION		MANUFACTURERS CATALOG NUMBER
Stock Description	Stock #	Thomas & Betts
Tie Cable Black Miniature	060700	TY100-18X
Tie Cable 8.5" x .13" Black	058001	L-8-40-0-D
Tie Cable 8.5" x .13" Natural	058002	L-8-40-9-D
Tie Cable 8.5" x .13" Brown	058003	L-8-40-1-D
Tie Cable 8.5" x .13" Red	058004	L-8-40-2-D
Tie Cable 8.5" x .13" Orange	058005	L-8-40-3-D
Tie Cable 8.5" x .13" Yellow	058006	L-8-40-4-D
Tie Cable 8.5" x .13" Green	058007	L-8-40-5-D
Tie Cable 8.5" x .13" Blue	058008	L-8-40-6-D
Tie Cable 8.5" x .13" Purple	058009	L-8-40-7-D
Tie Cable 8.5" x .13" Gray	058010	L-8-40-8-D
Tie Cable 27"	058061	L-28-120-9-L



# CONDUCTOR

Originator: DSmith

Date: 7/9/2007

Approval: DSmith

Date: 7/9/2007

Page 1 of 1

Revision: **NEW**

Stds Committee Approval:  
**Approved**

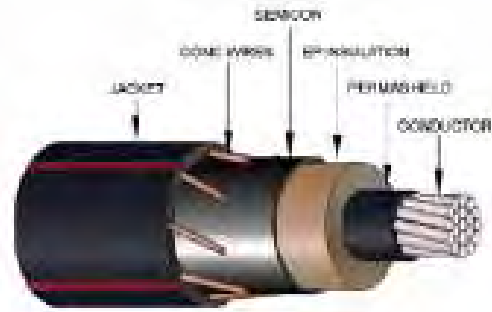

# CONDUCTOR





**Cable UG,  
EPR Insulated - 15kV**

Originator: DSmith

Date 5/28/2004

Approval: DSmith

Date: 6/28/2007

Page 1 of 1

Revision: **Updated detail specification reference.**

Stds Committee Approval:  
**Approved**

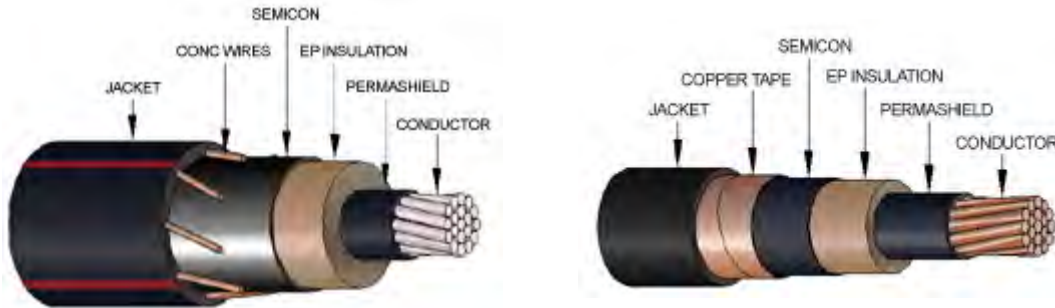

**Application:**

15kV, EPR underground jacketed cable with concentric neutral is used on multigrounded distribution systems. This cable may be installed above or below ground in conduit, direct buried, or underwater.

**Detail Specification: Refer to the following**

- #2 & 4/0 15kV Concentric Neutral Cable – 5110.0101
- 1000kcm Copper, 15kV Tape Shield Cable - 5110.0102
- 1000kcm Aluminum, 15kV Tape Shield Cable - 5110.0103

Reel dimensions are = Reel Outside Diameter (D) X Drum Width (W) X Drum Diameter (d)

**Approved Manufacturers: Kerite & Okonite**

**Details: All values are approximate.**

Description	Item No.	Diameter Over Insulation (Inches)	Diameter Over Jacket (Inches)	Cable Weight (lbs/kft)	Ampacity In Separate Conduits	Reel Size (in.) DxWxd Arbor = 3.125"	Reel Length +5% - 0%
Cable, #2 AL, 15KV, Jacketed, 175 MIL EPR Insulation, Full Concentric Neutral	051160	0.71	1.01	536	125	50X32X24	2500
Cable, #2 AL, 15KV, Jacketed, 220 MIL EPR Insulation, Full Concentric Neutral	051175	0.80	1.11	617	125	50X32X24	2500
Cable, 4/0 AL, 15KV, Jacketed, 175 MIL EPR Insulation, 1/3 Concentric Neutral	051170	0.93	1.24	814	245	58X32X24	2500
Cable, 4/0 AL, 15KV, Jacketed, 220 MIL EPR Insulation, 1/3 Concentric Neutral	051173	1.03	1.34	913	245	58X32X24	2500
Cable, 1000kcm AL, 15KV, Jacketed, 175 MIL EPR Insulation, Tape Shield	051180	1.58	1.96	1990	565	82X37X32	2000
Cable 1000kcm Copper, 15kV, Jacketed, 175 MIL EPR Insulation, Tape Shield	050826	1.58	1.96	4309	690	82X37X32	2000



**CABLE UG, ALUMINUM,  
600V XLP INSULATED**

Originator: DSmith

Date: 7/10/2006

Approval: J. Nieborsky

Date: 12/04/2012

Revision: #1 -Revised descriptions to match Maximo. #2 Changed Approved Manufacturers. #3 Added Nexans to approved manufacturer list.

Stds Committee Approval:  
**Approved**

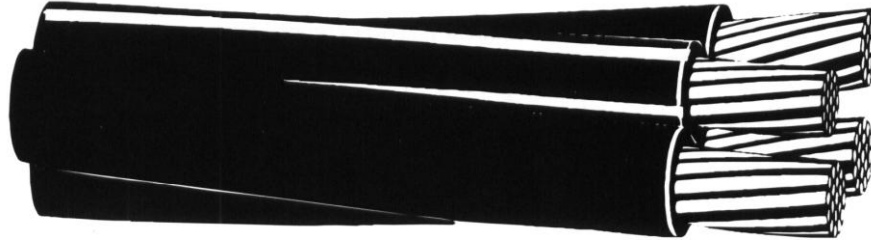

**Application:** 600 volt underground service cable shall be used for secondaries and services in conduit or direct buried, in wet or dry locations.

**Specification:**

This 600 volt secondary URD cable shall meet or exceed the following applicable ASTM specifications:

**Aluminum**

- B-230 Aluminum 1350-H19 Wire for Electrical Purposes.
- B-231 Aluminum 1350 Conductors, Concentric-Lay-Stranded.
- B-609 Aluminum 1350 Round Wire, Annealed and Intermediate Tempers, for Electrical Purposes.
- B-901 Compressed Round Stranded Aluminum Conductors Using Single Input Wire.

**Copper:**

- B-1 Hard-Drawn Copper Wire.
- B-3 Soft or Annealed Copper Wire.
- B-8 Concentric-Lay-Stranded Copper Conductors, Hard, Medium-Hard, or Soft.

In addition, this 600 volt secondary URD cable shall meets or exceeds all applicable requirements of ICEA S-105-692 for cross-linked polyethylene insulated conductors and UL Standard 854 for Type USE-2.

**Cable Assembly:** The conductors of multiple conductor cables shall be twisted together with a lay of not greater than 60 times the outside diameter of an insulated phase conductor. Each conductor of a cable shall have a permanent continuous marking, identifying it from other conductors of the cable, and showing the manufacturer's name or trademark, year of manufacture, voltage rating, conductor size, type of insulation and NEC type "USE-2."

As a minimum, triplex cables shall have one phase conductor marked with "Phase A" identification. Sequential footage markers may be located on either phase conductor or neutral.



**CABLE UG, ALUMINUM,  
600V XLP INSULATED**

Originator: DSmith

Date: 7/10/2006

Approval: J. Nieborsky

Date: 12/04/2012

Page 2 of 3

Revision: #1 -Revised descriptions to match Maximo. #2 Changed Approved Manufacturers. #3  
Added Nexans to approved manufacturer list.

Stds Committee Approval:  
**Approved**

As a minimum, quadraplex cables shall have one phase conductor marked with "Phase A" identification, a second phase conductor marked with "Phase B" identification. Sequential footage markers may be located on any phase conductor or the neutral.

**Packaging and Marking:** Cable shall be shipped on nonreturnable reels of NEMA WC26 dimensions with in either "cut to order" or standard lengths as specified. Conductor shall be level wound on reel. Both ends of the wire shall be fastened to the reel. Conductor shall be protected by heavy wrapping, either heavy fiberboard or 10 mil. plastic. The net weight, length, conductor size and kind, stranding, voltage class, purchaser's order number, and manufacturer's name, address, starting footage of the cable (at the hub), and serial number shall be marked on a durable label or tag and securely fastened to the outside of the reel.

Reels shall be free of foreign objects (nails, etc.) that could damage the conductor during transit or while dispensing. Reel size shall be a minimum of 1-1/2" larger than wound conductor. Reels shall not exceed maximum flange diameter of 66 inches nor a maximum outside width of 32-1/2 inches. The arbor hole shall have a diameter of 2-1/2 inches.

**Shipping:** All cable shall be shipped on an open flatbed truck. Reel flanges shall be vertical and positioned to be unloaded from the side. The cable shall be protected by heavy wrapping, either heavy fiberboard or 10 mil plastic. All cable ends shall be sealed with approved end caps to prevent the entrance of moisture during shipping and storage.

**Tests:** The cable shall be tested in accordance with the applicable requirements of ICEA Publication No. S-105-692 (latest revision) except "sparking testing" shall not be permitted. Results of these tests shall be supplied to the Standards Engineer prior to shipping if requested.

**Inspection:** Inspection may be made at the manufacturer's plant or upon receipt, at the option of the purchaser. Failure to meet any of the requirements of this specification will be cause for rejection.



CHELAN COUNTY  
**PUBLIC UTILITY DISTRICT**  
*Owned By The People We Serve*



**CABLE UG, ALUMINUM,  
600V XLP INSULATED**

Originator: DSmith

Date: 7/10/2006

Approval: J. Nieborsky

Date: 12/04/2012

Revision: #1 -Revised descriptions to match Maximo. #2 Changed Approved Manufacturers. #3  
Added Nexans to approved manufacturer list.

Stds Committee Approval:  
**Approved**

**Approved Manufacturers: Southwire, BICC General (Formerly Alcan), & Nexans**

Stock No	Description	Dia. (inches)	*Amps/Phase (IN DUCT)	Wt. Per 1000 Ft (lbs)	Reel Feet - 0 +10%
051750	CABLE, UG, 600V, 1/0 AL, SGL COND, "HARVARD", 1000' REEL	.512	150	146	1000
052000	CABLE, UG, 600V, #4/0 AL, SGL COND, "BELOIT", 1000' REEL	.658	225	263	1000
052300	CABLE, UG, 600V, 350KCM AL, SGL COND, "RUTGERS", 2000' REEL	.831	305	422	2000
052350	CABLE, UG, 600V, 500KCM AL, SGL COND, "EMORY", 1000' REEL	.980	370	580	1000
052400	CABLE, UG, 600V, 750KCM AL, SGL COND, "SEWANEE", 500' REEL	1.188	470	854	500
055000	CABLE, UG, 600V, AL, 1/0-2-1/0 AL, TRIPLEX, "BRUNEAU", 1000' REEL	1.106	160	387	1000
055150	CABLE, UG, 600V, #4/0-2/0-4/0 AL, TRIPLEX, "SWEETBRIAR", 1000' REEL	1.421	240	709	1000
055300	CABLE, UG, 600V, AL, 350-4/0-350, TRIPLEX, "WESLEYAN", 1000' REEL	1.795	320	1118	1000
055160	CABLE, UG, 600V, #4/0-4/0-4/0-2/0 AL, QUADRAPLEX, "WAKE FOREST ORLANDER", 1000' REEL	1.588	225	974	1000
055320	CABLE, UG, 600V, AL, 350-350-350-4/0, XLP, QUADRAPLEX, "SLIPPERY ROCK", 1100' REEL	2.006	305	1544	1100

\*Ampacity: 90°C conductor temperature, 20°C ambient, RHO 90, 100% load factor for three conductor triplex with neutral carrying only unbalanced load.



**CABLE, COPPER, 600V INSULATED  
Underground or Jumpers**

Originator: DSmith

Date: 6/18/2007

Approval: J Mitchell

Date: 7/6/11

Page 1 of 1

Revision: **NEW**

Stds Committee Approval:  
**Approved**



**Application:** This type of cable is suitable for use in general purpose wiring applications and may be installed in raceway, conduit, direct burial and aerial installations (Jumper wires). It is gasoline, oil and sunlight resistant.

**Jumper Wires:** The maximum rated circuit voltage is 600 volts. Although not treated as insulation, the covering on jumper riser wire does reduce faults due to atmospheric conditions, shorts caused by excessive vibrations, and faulting caused by objects crossing the leads.

**Specifications:**

**Conductor:** Stranded conductor, uncoated soft-drawn or annealed copper per ASTM B3 and B8.

**Insulation:** The insulation shall be rated 600 volt, flame retardant, cross-linked polyethylene (XLPE) insulated, NEC Type RHH-RHW-2-USE-2, The insulation shall be a black cross-linked polyethylene compound rated 90 degrees C for dry or damp locations and 75°C for wet locations per ASTM D470 and UL 44. Black pigment shall be uniformly dispersed carbon black particles for sunlight resistance.

**Marking:** Wire shall be marked at regular intervals with the manufacturer's name or symbol, wire size, conductor material, NEC type, voltage rating, and UL symbol.

**Packaging:** The cable shall be one continuous length and wound on a non-returnable plywood or solid wood reel that meets the requirements of NEMA WC 26 Binational Wire and Cable Packaging standard, or is equivalent. The reels shall be shipped with their flanges vertical or on pallets suitable for handling by a forklift. Individual reels shall be marked with manufacturer's name or symbol, catalog number, and name of the item, and the Districts purchase order number. A packing slip shall be included with each shipment.

**Approved Manufacturers: All**

Stock No	Description	Dia. (inches)	*Amps/P hase Free Air	*Amps/Ph ase (IN DUCT)	Wt. Per 1000 Ft (lbs)	Reel Feet - 0 +10%
041652	CABLE, #2 AWG 7 Strand CU, 600V XLP, TYPE USE-2, BLACK	0.292	190	130	NA	1000
054450	CABLE, #4 AWG 7 Strand CU, 600V XLP, TYPE USE-2, BLACK	0.358	140	95	161	1000
054455	CABLE, 2/0 AWG 19 Strand CU, 600V XLP, TYPE USE-2, BLACK	0.568	300	195	481	500
054460	CABLE, 4/0 AWG 19 Strand CU, 600V XLP, TYPE USE-2, BLACK	0.638	405	260	NA	500
054500	CABLE, 350KCM 37 Strand CU, 600V XLP, TYPE USE-2, BLACK	0.80	570	350	1170	500
052500	CABLE, 500KCM 37 Strand CU, 600V XLP, TYPE USE-2, BLACK	0.93	700	430	1648	500

\* NEC Ampacity Rating for a single conductor in free air, ambient temperature of 30 °C, wet or dry locations, 75 °C conductor temperature for USE-2 insulation



**WIRE, ACSR, BARE STRANDED**  
(Aluminum Conductor, Steel Reinforced)

Originator: DSmith

Date: 7/10/2012

Approval: J. Nieborsky

Date: 10/22/2012

Page 1 of 1

Revision: Maximized footage on reels. Approved manufacturers change.

Stds Committee Approval:

**Approved**



**Application:** Used as bare overhead transmission cable and as primary and secondary distribution cable. ACSR offers optimal strength for line design. Variable steel core stranding enables desired strength to be achieved without sacrificing ampacity.

**Common Name:** ACSR Overhead Wire

**Specification:**

The ACSR bare conductor shall meet or exceed the following ASTM specifications for right hand lay stranding.

- B-230 Aluminum Wire, 1350-H19 for Electrical Purposes
- B-231 Aluminum Conductors, Concentric-Lay-Stranded
- B-232 Aluminum Conductors, Concentric-Lay-Stranded, Coated Steel Reinforced (ACSR)
- B-341 Aluminum-Coated Steel Core Wire for Aluminum Conductors, Steel Reinforced (ACSR/AZ)
- B-498 Zinc-Coated Steel Core Wire for Aluminum Conductors, Steel Reinforced (ACSR)

Actual lengths shall conform to wood reels supplied by the manufacturer and shall be **minus 0 % or plus 15%**.

**Packaging and Marking:** The net weight, length, conductor size and name, purchaser's order number and manufacturer's name, address, and serial number shall be marked on a durable label and securely fastened to the outside of the reel or coil. \*Reels shall be of NEMA WC26 dimensions and free of foreign objects (nails, etc.) that could damage the conductor during transit or while dispensing. See table for reel sizes and wire lengths.

**Shipping:** All cable shall be shipped on an open flatbed truck. Reel flanges shall be vertical and positioned to be unloaded from the side. All reels shall have a protective wrap. Wire shall be shipped on nonreturnable reels with one continuous length. **DO NOT LAY REELS ON THEIR SIDES.**

**Approved Manufacturers: Southwire & BICC General (Formerly Alcan)**

Item No	Maximo Description	Wire Lbs/Kft	REEL Information		
			Size*	Footage	Weight (lbs)
035040	WIRE, ACSR, #4, 6/1, "SWAN"	57	NR 30.22	12,100	755
035060	WIRE, ACSR, #2, 6/1, "SPARROW"	91	NR 30.22	12,600	1,227
035100	WIRE, ACSR, #2/0, 6/1, "QUAIL"	183	NR 42.28	10,500	2,089
035140	WIRE, ACSR, #4/0, 6/1, "PENGUIN"	291	NR 42.28	6,400	2,030
035180	WIRE, ACSR, 266.8KCM, 26/7, "PARTRIDGE"	367	NR 66.28	13,700	5,425
035190	WIRE, ACSR, 336.4KCM 30/7, "ORIOLE"	526	NR 66.28	9,900	5,605
035200	WIRE, ACSR, 336.4KCM, 26/7, "LINNET"	462	NR 66.28	10,700	5,341
035207	WIRE, ACSR, 397.5KCM, 26/7, "IBIS"	546	NR 66.28	9,000	5,311
035215	WIRE, ACSR, 477 KCM, ACSR 26/7, "HAWK"	656	NR 66.28	7,700	5,449
035220	WIRE, ACSR, 636KCM, 26/7, "GROSBEAK"	874	NR 66.28	5,400	5,117
035300	WIRE, ACSR, 795KCM, 26/7, "DRAKE"	1093	NR 66.28**	4,400	5,207
034960	WIRE, ACSR, 954KCM, 54/7, "CARDINAL"	1227	NR 66.28**	3,800	5,060
035310	WIRE, ACSR, 1272KCM, 45/7, "BITTERN"	1432	NR 66.28**	2,800	4,407
035315	WIRE, ACSR, 1780KCM, 84/19, "CHUKAR"	2071	NR 66.28**	1,900	4,332

\*NR = Non-Returnable Wooden Reel, RMT = Returnable, Steel Reels, Deposit Required.

NR 66.28\*\* Only for maintenance repairs, normally ordered on RMT reels on a project basis.



**WIRE, AAC, BARE-STRANDED**  
**(All Aluminum Conductor)**

Originator: DSmith      Date: 7/7/06

Approval: J. Nieborsky      Date: 10/22/2012

Revision: Maximized footage on reels. Change in approved manufacturers.

Stds Committee Approval:  
**Approved**



**Application:** AAC Wire is used primarily for overhead transmission and primary and secondary distribution, where Ampacity must be maintained and a lighter conductor (compared to ACSR) is desired, when conductor strength is not a critical factor.

**Common Name:** AAC Overhead Wire

**Specification:**

The AAC bare conductor shall meet or exceed the following ASTM specifications for right hand lay stranding.

- B-230 Aluminum Wire, 1350-H19 for Electrical Purposes.
- B-231 Aluminum Conductors, Concentric-Lay-Stranded.

**Construction**

Aluminum alloy 1350-H19 wires, concentrically stranded.

Actual lengths shall conform to wood reels supplied by the manufacturer and shall be **minus 0 % or plus 15%**.

**Packaging and Marking:** The net weight, length, conductor size and name, purchaser's order number and manufacturer's name, address, and serial number shall be marked on a durable label and securely fastened to the outside of the reel or coil. \*Reels shall be of NEMA WC26 dimensions and free of foreign objects (nails, etc.) that could damage the conductor during transit or while dispensing. See table for reel sizes and wire lengths.

**Shipping:** All cable shall be shipped on an open flatbed truck. Reel flanges shall be vertical and positioned to be unloaded from the side. All reels shall have a protective wrap. Wire shall be shipped on nonreturnable reels with one continuous length. **DO NOT LAY REELS ON THEIR SIDES.**

**Approved Manufacturers: Southwire, Nexans & BICC General (Formerly Alcan)**

Item No	Maximo Description	Wire Lbs/Kft	REEL Information		
			Size*	Footage	Wt (lbs)
034730	Wire, #2/0 AAC, 7strand, Bare, "Aster"	125	NR 42.28	12,400	1722
034760	Wire, AAC, #4/0, 19 Strand, "Sunflower"	198	NR 42.28	7,700	1690
034800	Wire, AAC, #4/0, 7 Strand, "Oxlip"	198	NR 42.28	7,700	1690
034820	Wire, AAC, 336.4kcm, 19 Strand, "Tulip"	315	NR 66.28	12,900	4453
034850	Wire, AAC, 336.4kcm, 19 Strand, "Tulip", Non Specular	315	NR 66.28	12,900	4453
034840	Wire, AAC, 477kcm, 19 Strand, "Cosmos"	447	NR 66.28	8,500	4179
034920	Wire, AAC, 636kcm, 37 Strand, "Orchid"	596	NR 66.28	6,100	4056
034923	Wire, AAC, 636kcm, 37 Strand, "Orchid", Non Specular	596	NR 66.28	6,100	4056
034954	Wire, AAC, 954 Kcm, 37 Strand, "Magnolia", Non Specular	894	NR 66.28**	4,200	4181

\*NR = Non-Returnable Wooden Reel, RMT = Returnable, Steel Reels, Deposit Required.  
 NR 66.28\*\* Only for maintenance repairs, normally ordered on RMT reels on a project basis.



**ALUMINUM TIE WIRE**

Originator: DSmith

Date: 7/7/06

Approval: DSmith

Date: 7/7/06

Revision: **NEW**

Stds Committee Approval:  
**Approved**



**Application:** Generally used in overhead transmission and distribution line construction to mechanically secure components such as conductors to pin insulators. Also used for grounding applications in line construction.

**Specifications:** The tie and ground wire meets or exceeds ASTM specification:

- B-609 Soft Aluminum Wire. 1350-0 for Electrical Purposes.

The wire shall be made of solid, soft drawn 1350-0 aluminum wire.

**Packaging and Marking:** Items shall be suitably packaged to prevent damage. The container shall be convenient for handling and storage. Manufacturer's name or symbol and catalog number shall be on each part or (and) its packaging.

10 lbs. Reels

Spools shall be 12" flange x 4" traverse x 8" drum with a 2" diameter arbor hole.

**Approved Manufacturers:** Southwire, NEHRING, TIPPER TIE

PUD IDENTIFICATION			
Stock Description	Stock No.	Reel size (feet)	WT / 1000Feet (Lbs)
WIRE, ALUMINUM TIE, #6	034600	1050	24.1
WIRE, ALUMINUM TIE, #4	034620	325	38.4
WIRE, ALUMINUM TIE, #2	034640	1000	61



**WIRE, COPPER, BARE SOLID  
SOFT DRAWN ANNEALED**

Originator: DSmith

Date: 7/7/06

Approval: DSmith

Date: 6/6/2007

Page 1 of 1

Revision: **NEW**

Stds Committee Approval:  
**Approved**

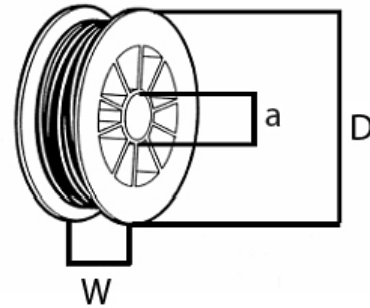

**Application:** Bare solid soft-drawn annealed copper conductor is used for jumpers, tie wires, grounds etc.

**Common Name:** Copper Jumper or "Mousing" Wire

**Specification:**

Conductor shall be bare copper cable that meets or exceeds the following ASTM specifications.

- B-3 Soft or Annealed Copper Wire.

**Packaging and Marking:** The net weight, length, conductor size and name, purchaser's order number and manufacturer's name, address, and serial number shall be marked on a durable label and securely fastened to the outside of the reel or coil. \*Reels shall be of NEMA WC26 dimensions and free of foreign objects (nails, etc.) that could damage the conductor during transit or while dispensing. See table for reel sizes and wire lengths.

Spool dimensions are = Outside Diameter (**D**) X Drum Width (**W**) X Arbor Size (**a**)

**Shipping:** No special shipping Instructions

**Approved Manufacturers: SouthWire, Republic Wire, Service Wire, Nehring**

Item No	Description	Package Type	Reel Size DxWxa	Length (ft)	Weight Pounds
036085	Wire, Copper, #14, Bare Solid, Soft Drawn, "Mousing Wire", 2000' Reel	Spool	12" x 4" x 2"	2000	25
035920	Wire, Copper, #6, Bare Solid, Soft Drawn	Spool	12" x 4" x 2"	315	25
035960	Wire, Copper, #4, Bare Solid, Soft Drawn	Spool	12" x 4" x 2"	198	25





**COPPER, BARE STRANDED, SOFT DRAWN**

Originator: DSmith

Date: 7/7/06

Approval: DSmith

Date: 6/15/2007

Revision: Reduced Spool sizes

Stds Committee Approval:  
**Approved**

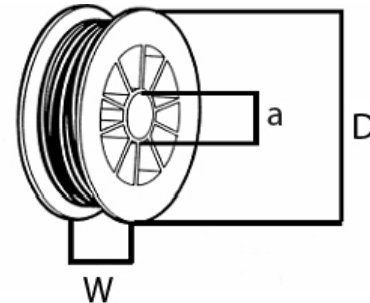

**Application:** Bare stranded soft-drawn (annealed) copper cable are suitable for overhead transmission and distribution applications such as uninsulated hook up, jumpers, and grounds in electrical construction.

**Specification:**

Conductor shall be bare copper cable that meets or exceeds the following ASTM specifications.

- B-3 Soft or Annealed Copper Wire.
- B-787 19 Wire Combination Unilay-Stranded Soft copper wire.
- B-8 Concentric-Lay-Stranded Hard, Medium-Hard or Soft Copper Conductor.

**Packaging and Marking:** The net weight, length, conductor size and name, purchaser's order number and manufacturer's name, address, and serial number shall be marked on a durable label and securely fastened to the outside of the reel, spool, or coil. See table for spool sizes and wire lengths.

**Shipping:** No special shipping Instructions

**Approved Manufacturers: Southwire, Republic Wire, Service Wire, Nehring**

Spool dimensions are = Outside Diameter (**D**) X Drum Width (**W**) X Arbor Size (**a**)

Item No	Description	Wire Lbs/kft	Spool Size DxWxa	Length (ft)	Weight Pounds
036080	WIRE, COPPER, #2, 7 STRAND, SOFT DRAWN	204.9	12" X 8" X 2"	250	50
036130	WIRE, COPPER, #2/0, 19 STRAND, SOFT DRAWN	410.9	18"X14" X2"	500	205
036180	WIRE, COPPER, #4/0, 19 STRAND, SOFT DRAWN	653.3	24"X12"X3"	500	327
036230	WIRE, COPPER, 250KCM, 19 STRAND, SOFT DRAWN	771.9	27"X15X3"	500	385
036290	WIRE, COPPER, 500KCM, 37 STRAND, SOFT DRAWN	1543.8	30"X22"X3"	500	772



**- Material Catalog -**

**CONDUCTOR**

**5111.05**

CHELAN COUNTY  
**PUBLIC UTILITY DISTRICT**  
*Owned By The People We Serve*



**COPPER, BARE STRANDED, SOFT DRAWN**

Originator: DSmith

Date: 7/7/06

Approval: DSmith

Date: 6/15/2007

Page 2 of 2

Revision: Reduced Spool sizes

Stds Committee Approval:

**Approved**



**COPPER, BARE SOLID  
 HARD DRAWN / MEDIUM HARD DRAWN**

Originator: DSmith

Date: 7/7/06

Approval: DSmith

Date: 6/6/2007

Page 1 of 1

Revision: **NEW**

Stds Committee Approval:  
**Approved**

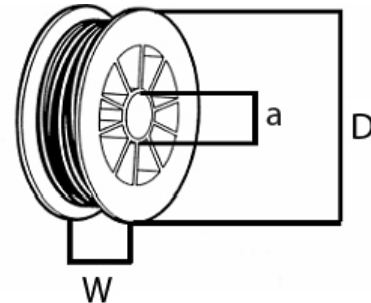

**Application:** Bare solid hard-drawn copper conductor for maintenance of existing lines and adding a phase to existing spans. **Do not use these conductors for new construction.**

**Specification:**

Conductor shall be bare copper cable that meets or exceeds the following ASTM specifications.

- B-1 Hard-Drawn Copper Wire.
- B-2 Medium-Hard Copper Wire.

**Packaging and Marking:** The net weight, length, conductor size and name, purchaser's order number and manufacturer's name, address, and serial number shall be marked on a durable label and securely fastened to the outside of the reel or coil. \*Reels shall be of NEMA WC26 dimensions and free of foreign objects (nails, etc.) that could damage the conductor during transit or while dispensing. See table for reel sizes and wire lengths.

Spool dimensions are = Outside Diameter (**D**) X Drum Width (**W**) X Arbor Size (**a**)

**Shipping:** No special shipping Instructions

**Approved Manufacturers:** BICC, Southwire, Nehring, Service Wire, Republic Wire

Item No	Description	Wire Lbs/kft	Spool Size DxWxa	Length (ft)	Weight Pounds
035900	WIRE, COPPER, #6, SOLID, HARD DRAWN	79.4	12" x 4" x 2"	315	25
035940	WIRE, COPPER, #4, SOLID, HARD DRAWN	126.3	12" x 4" x 2"	198	25
035980	WIRE, COPPER, #2, SOLID, MEDIUM-HARD DRAWN	200.9	12" x 4" x 2"	124	25



**COPPER, BARE STRANDED, HARD DRAWN**

Originator: DSmith

Date: 7/10/2006

Approval: DSmith

Date: 6/18/2007

Revision: Added Spool Sizes

Stds Committee Approval:  
**Approved**

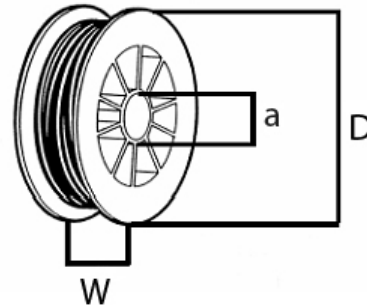

**Application:** Conductor shall be bare stranded hard-drawn copper wire for substation overhead bus use and maintenance of existing overhead lines.

**Specification:**

Conductor shall be bare copper cable that meets or exceeds the following ASTM specifications.

- B-1 Hard-Drawn Copper Wire.
- B-8 Concentric-Lay-Stranded Hard, Medium-Hard or Soft Copper Conductor.

**Packaging and Marking:** The net weight, length, conductor size and name, purchaser's order number and manufacturer's name, address, and serial number shall be marked on a durable label and securely fastened to the outside of the reel or coil. See table for spool sizes and wire lengths.

Spool dimensions are = Outside Diameter (**D**) X Drum Width (**W**) X Arbor Size (**a**)

**Shipping:** No special shipping Instructions

**Approved Manufacturers: BICC, REPUBLIC WIRE, SERVICE WIRE, NEHRING**

Item No	Description	Wire Lbs/kft	Spool Size DxWxa	Length (ft)	Weight Pounds
036050	WIRE, COPPER, #2, 7 STRAND, HARD DRAWN	204.9	24"X12"X3"	500	103
036140	WIRE, COPPER, #2/0, 7 STRAND, HARD DRAWN	410.9	24"X12"X3"	500	206
036170	WIRE, COPPER, #4/0, 7 STRAND, HARD DRAWN	653.3	24"X12"X3"	500	327



**CABLE, OH ALUMINUM  
600V INSULATED MULTIPLEX**

Originator: DSmith

Date: 12/14/2006

Approval: J. Nieborsky

Date: 12/04/2012

Page 1 of 1

Revision: **Change to approved manufacturers**

Stds Committee Approval:

**Approved**



**Application:**

600 volt overhead aluminum service cable shall be used for secondaries and services to serve electric loads.

**Common Name:** Overhead Secondary Wire

**Specification:** 600 volt overhead concentric or compressed aluminum XLPE insulated cable, shall meet the following requirements.

**Material:** Cable shall be manufactured per latest revision of ICEA S-61-402 and shall consist of one or more insulated conductors twisted around a bare ACSR neutral supporting conductor. Cable shall be suitable for normal continuous operation at 75 degrees C without damage.

**Packaging and Marking:** The net weight, length, conductor size and name, voltage class, purchaser's order number and manufacturer's name, address, and serial number shall be marked on a durable label and securely fastened to the outside of the reel or coil. \*Reels shall be of NEMA WC26 dimensions and free of foreign objects (nails, etc.) that could damage the conductor during transit or while dispensing. Quadruplex conductor must have extruded ridge for phase identification. The cable assemblies shall bear the following surface markings at intervals not to exceed 24 inches: Manufacturers Name, Plant of Manufacture, XLPE, and Year of Manufacture.

**Shipping:** All cable shall be shipped on an open flatbed truck. Reel flanges shall be vertical and positioned to be unloaded from the side. The cable shall be tarped or each reel shall be individually wrapped during shipment. Cable shall be shipped (on nonreturnable reels/in coils) with one continuous length.

**Approved Manufacturers: NEXANS, SOUTHWIRE & BICC GENERAL (Formerly Alcan)**

Item No	Description	Wt (lbs /1000ft)	Amps/Phase	Reel Size	Reel Wt. (Lbs)	Reel (Ft.)
034400	CABLE, OH, 600V, #4 ACSR, DUPLEX, "TERRIER", HAND COIL	115	90	Coil Only	60	500
034500	CABLE, OH, 600V, #2 AL, TRIPLEX, "COCKLE", HAND COIL	228	120	Coil Only	114	500
034420	CABLE, OH, 600V, #2 AL, TRIPLEX, "COCKLE"	228	120	36"X27.5"x1.5"	420	1800
034440	CABLE, OH, 600V, #2/0 AL, TRIPLEX, "CAVOLINA", 1500	453	185	42"X30"X1.5	698	1500
034470	CABLE, OH, 600V, #4/0 AL, TRIPLEX, "CERAPUD"	681	245	50"X36.5X2"	704	1000
034490	CABLE, OH, 600V, #2 AL, QUADRAPLEX, "PALOMINO"	347	105	42"X30"X2"	660	1800
034540	CABLE, OH, 600V, #2/0 AL, QUADRAPLEX, "GRULLO"	677	160	49"X36"X2"	1060	1500
034550	CABLE, OH, 600V, #4/0 AL, QUADRAPLEX, "APPALOOSA"	1038	210	50"X36"X2"	1070	1000



**GALVANIZED GUY WIRE**

Originator: DSmith

Date:12/13/2010

Approval: DSmith

Date:7/5/2007

Page 1 of 1

Revision: J Mitchell

Date:5/13/2011

Stds Committee Approval:  
**Approved**



**Application:** This is an aluminum-clad steel wire that provides corrosion resistance similar to solid aluminum and eight times the strength. It used for down guys to anchor angle poles and deadends on distribution & transmission lines.

**Material:** ER 3008 Alumoweld Type M Guy Strand

Designation	Number & Diameter of Individual Strands	Nominal Dia of Strand	Breaking Load Lbs	LBS/1000 ft	Ohms/ 1000 Ft
6M	7 X .081"	0.242	6000	104	1.13
12.5M	7 X .114"	0.343	12,500	208	0.56
25M	7 x .173"	0.519	25,000	475	0.25

**Packaging and Marking:** The steel wire strand shall be shipped in (compact coils or non-returnable reels). Compact hand coils shall have a maximum outside diameter of 29", a minimum outside diameter of 28" and a maximum width of 3-3/4". The reels shall be free of foreign objects (nails, etc.) that could damage the conductor during transit or while dispensing. The marking tags shall include GROSS. TARE, AND NET WEIGHTS. Manufacturer's name or symbol and catalog number shall be on each part and/or its packaging.

**Approved Manufacturers: ALFL and CONEX CABLE**

Item No.	Description	Code	Reel Size DxWxdxa	Length (feet)	Weight (lbs)
034300	WIRE, GUY, 6M, 7 STRAND, 500' HAND COIL	6M-AW7	Hand Coil	500	52LB
034320	WIRE, GUY, 12.5M, 7 STRAND, 250' HAND COIL	12.5M-AW7	Hand Coil	250	52LB
034325	WIRE, GUY, 12.5M, 7 STRAND, 10,000' REEL	12.5M-AW	40x24x30	10,000	2,080
034330	WIRE, GUY, 25M, 7 STRAND, 5000' REEL	25M-AW7	40x24x18	5,000	2,375
034340	WIRE, GUY, 25M, 7 STRAND, 250' HAND COIL	25M-AW7	Hand Coil	250	525LB



**TREE WIRE, AAC**

Originator: DSmith

Date: 8/7/2006

Approval: DSmith

Date: 7/5/2007

Revision: **NEW**

Stds Committee Approval:  
**Approved**



**Application:** Used primarily for, but not limited to, overhead distribution lines in areas of heavy tree congestion to reduce number of nuisance tripping of protective devices. Installed on insulators, otherwise treated as a bare conductor. Requires engineering approval to use.

**Specifications:** The wire shall meets or exceeds the following ASTM specifications:

- B-230 Aluminum Wire, 1350-H19 for Electrical Purposes.
- B-231 Aluminum Conductors, Concentric-Lay-Stranded.
- B-232 Aluminum Conductors, Concentric-Lay-Stranded, Coated Steel Reinforced (ACSR).
- B-399 Concentric-Lay-Stranded 6201-T81 Aluminum Alloy Conductors.

It shall also meet all applicable requirements of ANSI/ICEA S-70-547.

It shall be constructed of Aluminum alloy 1350-H19, 6201, or ACSR conductors, concentrically stranded and covered with crosslinked polyethylene (XLP) as specified below.

**Packaging and Marking:** Items shall be suitably packaged to prevent damage. The container shall be convenient for handling and storage. Manufacturer's name or symbol and catalog number shall be on each part or (and) its packaging.

**Shipping:** Must be delivered on a flatbed truck

**Approved Manufacturers: Southwire, ALCOA**

PUD IDENTIFICATION					
Stock Description	Stock No.	Lbs / 1000'	Reel Size (Feet)	Amps	Rated Strength (lbs)
Wire, Tree, #2 7STR, AAC, 45Mil XLP Covering, "Peach"	035400	84	7500	180	1210
Wire, Tree #2/0 7STR AAC, 60Mil XLP Covering, "Orange"	035440	172	3500	280	2260
Wire, Tree, #4/0 19str AAC, 60Mil XLP Covering, "Pomegranate"	035460	260	3800	370	3620
Wire, Tree, 336kcm 19STR AAC, 60Mil XLP Covering, "Annona"	035500	390	2500	495	5530
Wire, Tree, 477kcm 37STR AAC, 60Mil XLP Covering, "Huckelberry"	035520	565	3300	610	7820



**GROUND ROD, COPPER CLAD**

Originator: DSmith

Date: 7/12/2006

Approval: DSmith

Date: 7/5/2007

Page 1 of 1

Revision: **NEW**

Stds Committee Approval:  
**APPROVED**



**Application:** Copper clad ground rods provide grounding for overhead and underground distribution and transmission and for substation ground grids.

**Ordering Description:** Copper clad ground rod shall meet the requirements of ANSI/UL 467, latest revision the requirements listed below.

**Copper Jacket:** A 0.01" thick uniform layer of electrolyte copper shall be metallurgically bonded to the rigid steel core.

**Rod Ends:** One end shall be chamfered to resist mushrooming when driving. The other end shall be a blunt 45 degree conical point.

**Marking:** Each rod shall be clearly stamped with the manufacturer's name or trademark within 12" of the chamfered end.

**Packaging:** Ground rods shall be securely bound in bundles of five and protected from damage during shipment.

**Approved Manufacturers**

PUD IDENTIFICATION	MANUFACTURER CATALOG NUMBER			
	Stock No.	Joslyn	Blackburn	Eritech
GROUND ROD, 8' X 3/4", STEEL CORE, COPPER BONDED	028320	J8348	T&B 7508	613480
ROD, GROUNDING, 5/8" X 8', GALV.	165612			





**COPPER GROUNDING PLATE  
 For Pole Butts & Fiberglass Sleeves**

Originator: DSmith

Date: 11/13/2007

Approval: DSmith

Date: 11/13/2007

Page 1 of 1

Revision: **NEW**

Stds Committee Approval:  
**APPROVED**



**Figure 1**



**Figure 2**

**Application:** Copper ground plates can be attached to a pole butt or buried in a hole having a minimum depth of 5 ft. They are considered a made electrode without the addition of a ground rod. They are used in areas where standard ground rods are impossible to drive. The larger plate must be used if only one side of the plate is exposed to the earth. The smaller plate may be used if both sides are exposed to the earth.

**Specification:** Each plate consists of a 0.06" thick solid copper plate with a captive integral copper connector.

**Marking:** Each plate shall be clearly stamped with the manufacturer's name or trademark.

**Packaging:** Plates shall be securely bound in bundles of five and protected from damage during shipment.

**Approved Manufacturers**

PUD IDENTIFICATION			MANUFACTURER CATALOG NUMBER	
Stock Description	Stock No.	Figure	ERICO	Homac
PLATE, GROUND, UG CU .06" THICK 7.5" X 19.25" 144 SQ IN SURFACE WITH AN INTEGRAL COPPER CONNECTOR FOR #12-1/0 WIRE.	025882	1	UGP719	GG144E1/0
PLATE, GROUND, POLE CU .06" THICK 7.5" X 38.5" 288 SQ IN SURFACE WITH AN INTEGRAL COPPER CONNECTOR FOR #12-#2 WIRE.	025883	2	UGP738	GG288-E3-V1





# LABELS & SIGNS

Originator: DSmith

Date: 2/8/2007

Approval: DSmith

Date: 2/8/2007

Page 1 of 1

Revision: **NEW**

Stds Committee Approval:  
**Approved**

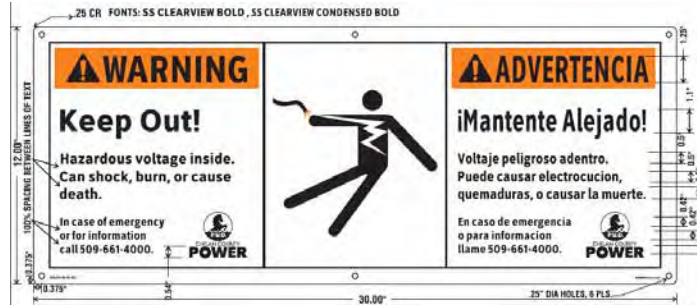

# LABELS & SIGNS





**High Voltage Equipment Warning  
Peel & Stick**

Originator: dsmith

Date: 1/14/2008

Approval: dsmith

Date: 1/17/2008

Page 1 of 3

Revision: **NEW**

Stds Committee Approval:

**Approved**

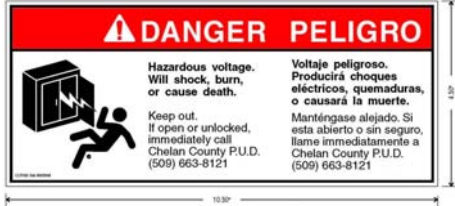

**Figure 1**  
“Danger Label”



**Figure 2**  
“Warning Label”

**Application:** This specification covers High Voltage Equipment Peel & Stick Labels. The “Warning Label “ is placed on the outside of equipment while the “Danger” label is placed on the inside.

**Specifications:**

Material: .002" tamperproof, UV-resistant and heat-resistant Acrylic film with permanent adhesive, Screen printed colors per Drawings shown, .002" clear Acrylic lamination, sizes per Drawings shown, slit liner for ease of installation.

**Packaging and Marking:** Items shall be suitably packaged to prevent damage. The Districts Stock number and the Manufacturer’s name or symbol and catalog number shall be on each part and its packaging.

**Approved Manufacturers:**

PUD IDENTIFICATION			MANUFACTURER CATALOG NUMBER	
Stock No.	Stock Description	Figure #	Electromark	MFG #2
045940	Label, Danger, High Voltage Equipment, Bilingual, 4.5" X 10.5"	1	CHL018-W-A2-C52	
045945	Label, Warning & Clearances, High Voltage Equipment, Bilingual, 7" X 11"	2	CHL017-W-A2-TV3	



**High Voltage Equipment Warning  
Peel & Stick**

Originator: dsmith

Date: 1/14/2008

Approval: dsmith

Date: 1/17/2008

Revision: **NEW**

Stds Committee Approval:

**Approved**

Figure 1, Stock #045940

**"Danger Label"**

4.50"

Figure 1, Stock #045940

**"Danger Label"**

**! DANGER PELIGRO**

**Hazardous voltage.  
Will shock, burn,  
or cause death.**

Keep out.  
If open or unlocked,  
immediately call  
Chelan County P.U.D.  
(509) 663-8121

**Voltaje peligroso.  
Producirá choques  
eléctricos, quemaduras,  
o causará la muerte.**

Manténgase alejado. Si  
esta abierto o sin seguro,  
llame inmediatamente a  
Chelan County P.U.D.  
(509) 663-8121



CCPUD Stk #045940

10.50"

5210.01 Label High Voltage Equipment Warning.doc





**High Voltage Equipment Warning  
Peel & Stick**

Originator: dsmith

Date: 1/14/2008

Approval: dsmith

Date: 1/17/2008

Revision: **NEW**

Stds Committee Approval:

**Approved**

Figure 2 -  
Stock # 045945  
"Warning Label"

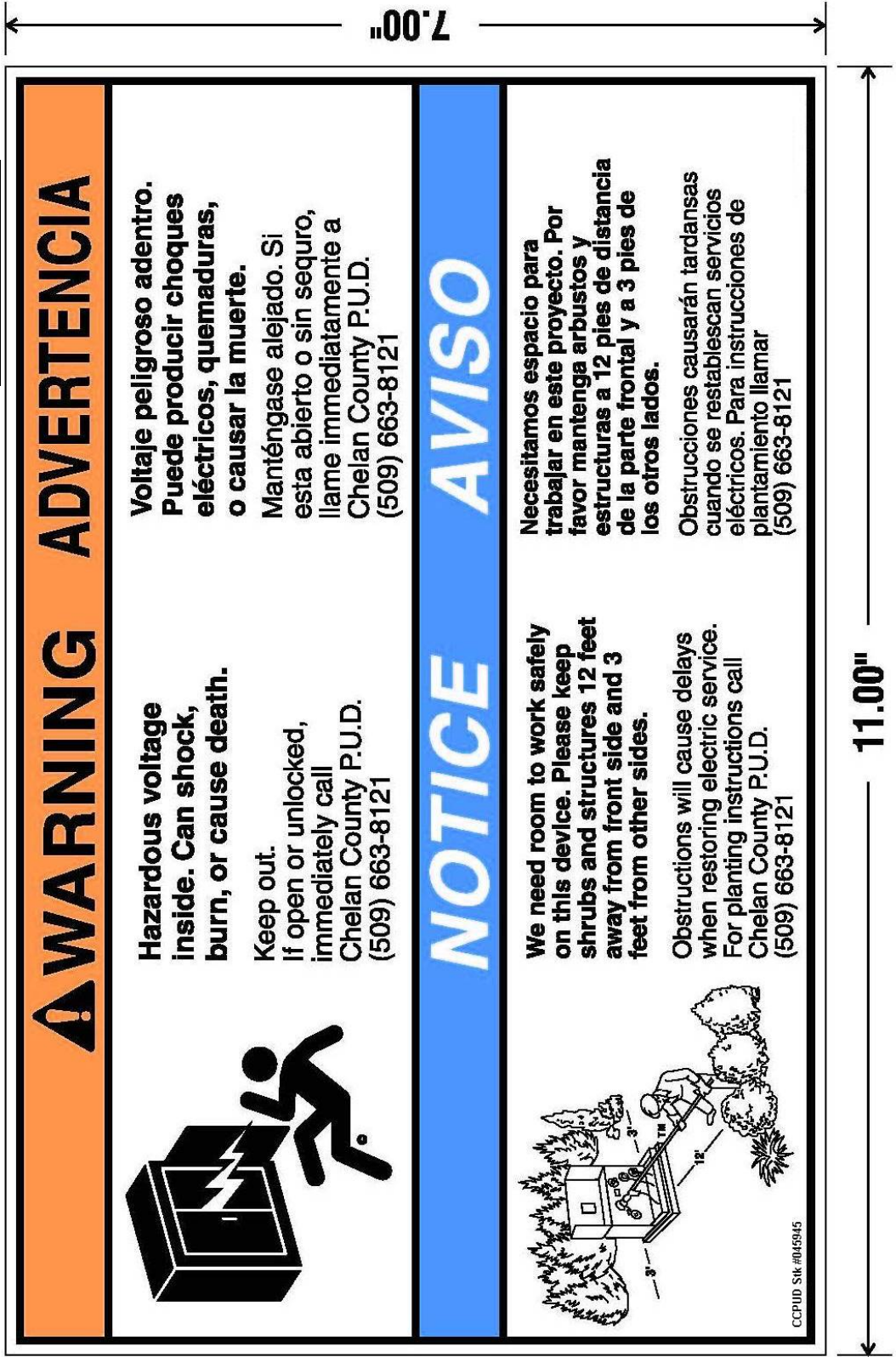

**ADVERTENCIA**  
**WARNING**

**Hazardous voltage inside. Can shock, burn, or cause death.**

Keep out.  
If open or unlocked, immediately call Chelan County P.U.D. (509) 663-8121

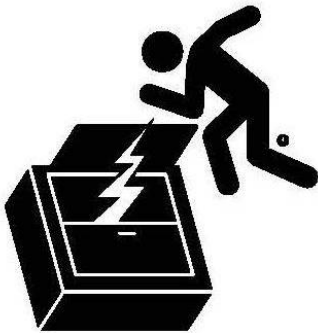

**Voltaje peligroso adentro. Puede producir choques eléctricos, quemaduras, o causar la muerte.**  
Manténgase alejado. Si esta abierto o sin seguro, llame inmediatamente a Chelan County P.U.D. (509) 663-8121

**AVISO**  
**NOTICE**

**We need room to work safely on this device. Please keep shrubs and structures 12 feet away from front side and 3 feet from other sides.**

Obstructions will cause delays when restoring electric service. For planting instructions call Chelan County P.U.D. (509) 663-8121

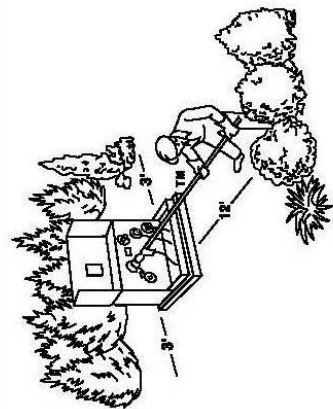

CCPUID Stk #045945



**SNOW FLAGS**

Originator: DSmith

Date: 11/7/2007

Approval: DSmith

Date: 12/10/2008

Page 1 of 1

Revision:

Stds Committee: **Approved**

**Application:** These units can be bolted to the side of the cabinet. The orange flag can be seen above the snow covered cabinet.

**Specification:** Each unit consists of a 72" steel rod with either a vertical or horizontal coil on one end, a single 6" hard plastic flag at the top, with 5/8 inch x 2 inch galvanized steel mounting hardware.

**Packaging and Marking:** Items shall be suitably packaged to prevent damage. The container shall be convenient for handling and storage. Manufacturer's name or symbol and catalog number shall be on each part or (and) its packaging.

**Approved Manufacturers: Nordic Fiberglass**

Stock #	DESCRIPTION	Nordic
045485	Marker, Flag, Snow, 72" Steel Rod W/ Vertical Coil On End, Hard Plastic Flag At Top, 6", With 5/8 Inch X 2" Inch Galvanized Steel Mounting Hardware.  Used For Marking Fire Hydrants	FF2
045486	Marker, Flag, Snow, 72" Steel Rod W/ Horizontal Coil On End, Hard Plastic Flag At Top, 6", With 5/8 Inch X 2 Inch Galvanized Steel Mounting Hardware.  Used For Marking Padmounted Equipment	FF2C

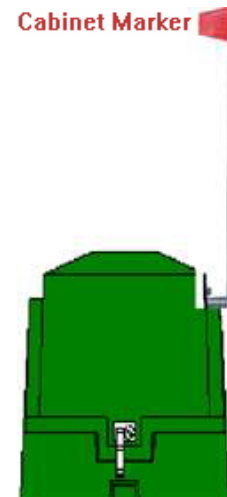
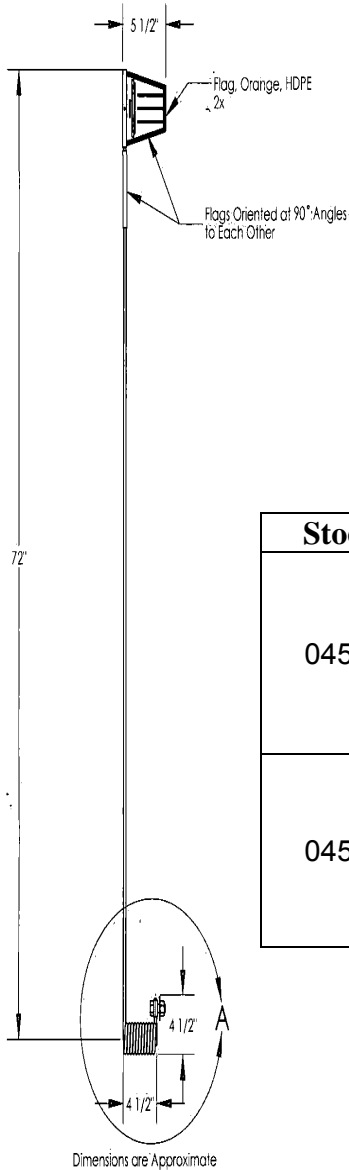





Sign – Fiberglass  
Substation Fence - Warning  
12" X 30"

Originator: dsmith

Date: 5/3/2007

Approval: dsmith

Date: 7/5/2007

Revision: NEW

Stds Committee Approval:

Approved

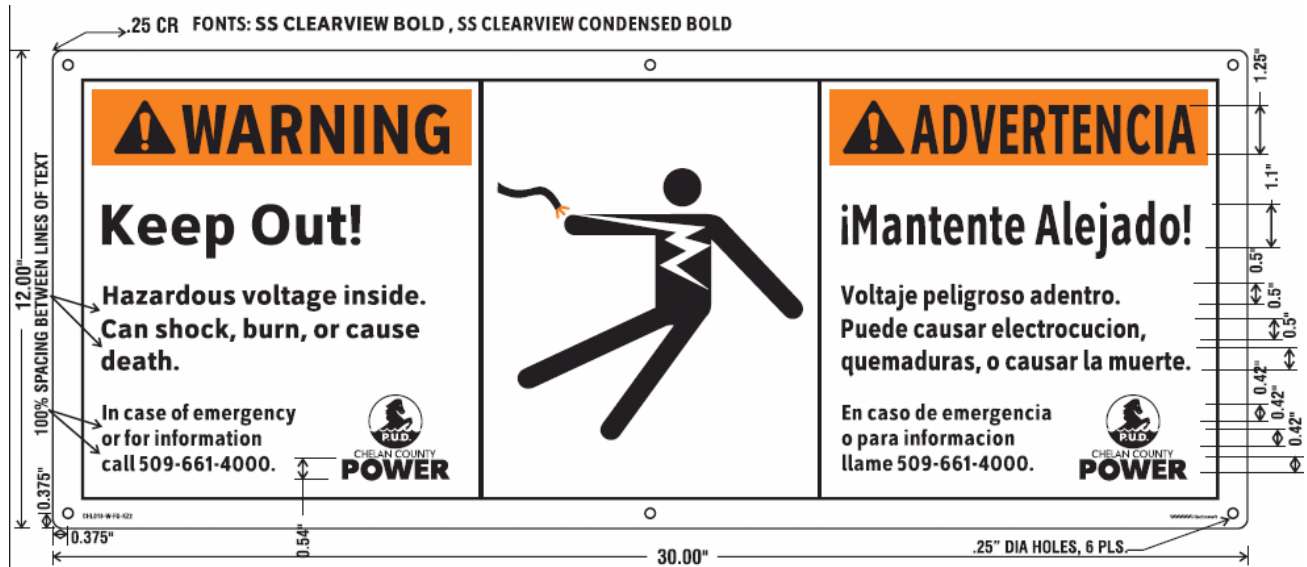

**Application:** This specification covers embedded fiberglass signs used as warning signs on substation fences per Construction Standard 810.002 "Substation Perimeter Fence Safety Sign Placement"

**Specifications:**

1. The signs shall be manufactured using acrylic modified polyester resin reinforced with chopped strand fiberglass, minimum of 28%. The images are embedded subsurface in the material to protect them on both the front as well as the backside.
2. The nominal thickness of a standard sign is .090" thick. The material shall resist deterioration from exposure to chemicals using DIN 42 115 Part 2 as listed in the following table.

Chemical	Rating
Mild Acids	Excellent
Water	Excellent
Mild Alkaline & Salt	Excellent
Solvents	Excellent

3. The sign shall not be defaceable by spraying with aerosol paint, or brushing and splashing paint. It may be wiped clean without marring or damaging the surface by using mineral spirits, soap and water, or mild solvents.
4. Corners, holes and edges: The signs shall have ¼" radius rounded corners or as specified. The signs shall have a clean, routed edge as opposed to a shear-cut edge.
5. Dimensions: The overall size of the sign shall be as specified with a +/- .03125" tolerance.
6. Flatness & Bubbles: The sign shall lay flat and have an even, non-rippled finish. A wavy surface or trapped air bubbles will not be acceptable. Finished signs shall have a maximum variation of 1/8" in the convex or concave direction when measured perpendicular to the nominal plane of the sign face.



**Sign – Fiberglass  
Substation Fence - Warning  
12” X 30”**

Originator: dsmith

Date: 5/3/2007

Approval: dsmith

Date: 7/5/2007

Revision: **NEW**

Stds Committee Approval:

**Approved**

- 7. Mounting Holes and Fence Clips: The sign shall be provided with six aluminum fence clips. The holes in the sign shall be spaced so that the fence clips will properly align themselves to the standard diamond repeat of the chain-link fence, including allowable deviations. The fence clip shall be fabricated from 0.090" thick aluminum and a 1/4-20 locking PEM insert. A tamper-proof or other suitable bolt shall be provided for each hole.
- 8. Packaging: Signs shall be packaged in a polyethylene bag or shrink packing. Each bag or box shall be identified with the date, quantity and part number. Bag or packages shall then be packaged in a corrugated carton. The outside of each carton shall be labeled with the District Item number as shown below.
- 9. UV Stability: The sign shall be remain readable and have little fading after 17,000 hours of exposure in a QUV weathering. Sample of weathered and printed sign shall remain on file at the manufacturer and is available for review by the District.
- 10. Workmanship and quality shall be such that all lettering is sharp, legible, straight and aligned properly. Smudges, misalignment, incorrect wording, misspelling, crooked letters, incorrect color, incorrect materials, or any other problems that show poor quality and workmanship will give sufficient cause to reject any marker. The products are to be guaranteed by the vendor to be free of workmanship or material defect for 12 years against chipping, fading, peeling and de-lamination.

**Approved Manufacturers:**

PUD IDENTIFICATION		MANUFACTURER CATALOG NUMBER	
Stock Description	Stock No.	Electromark	MFG #3
Sign, Fiberglass, Substation Fence Warning, 12" X 30"	100550	CHL-16-W-FG-KZ2	XXXXX



**Tags – Write-On Plastic  
with Black UV Resistant Plastic Ties**

Originator: D. Smith

Date: 5/4/2007

Approval: D. Smith

Date: 2/1/2008

Page 1 of 6

Revision: Revised Equipment Return Tag

Stds Committee Approval:

**Approved**

**Equipment Return**  
Equipment # \_\_\_\_\_  
CHECK ALL THAT APPLY  
 Backho Voltage  Lightning  
 Physical Damage  Corrosion  
 Change Out /  Oil Leak  
 Remove Only  
Comments On Back \_\_\_\_\_  
Field Loc ID \_\_\_\_\_  
WOP \_\_\_\_\_  
Date: \_\_\_\_\_ Initials \_\_\_\_\_  
Stock # \_\_\_\_\_  
Equipment # \_\_\_\_\_  
Serial # \_\_\_\_\_  
PCB Test# \_\_\_\_\_ Results: \_\_\_\_\_  
 Repair  Dispose  
Checked by: \_\_\_\_\_ Stock #015346

**Cable Reel Issue**  
Stock # \_\_\_\_\_  
Reel # \_\_\_\_\_  
WOP \_\_\_\_\_  
Comments: \_\_\_\_\_  
Date: \_\_\_\_\_ Initials \_\_\_\_\_

**Cable Reel Issue Tracking**  
Stock # \_\_\_\_\_  
Reel # \_\_\_\_\_  
WOP \_\_\_\_\_  
Comments: \_\_\_\_\_  
Date: \_\_\_\_\_ Initials \_\_\_\_\_  
DO NOT REMOVE

**Equipment Issue**  
Equipment # \_\_\_\_\_  
Stock # \_\_\_\_\_  
Date: \_\_\_\_\_  
Initials: \_\_\_\_\_  
Comments On Back \_\_\_\_\_

**Not Approved**  
Equipment # \_\_\_\_\_  
Stock # \_\_\_\_\_  
Date: \_\_\_\_\_  
Initials: \_\_\_\_\_  
Comments On Back \_\_\_\_\_

**Approved**  
Equipment # \_\_\_\_\_  
Stock # \_\_\_\_\_  
Date: \_\_\_\_\_  
Initials: \_\_\_\_\_  
Comments On Back \_\_\_\_\_

**Application:** This specification covers colored Write-on Plastic Tags with black ultraviolet resistant ties. They are used to track inventory during issues and returns.

**Material and Construction:**

1. Base material: high tensile .010" thick abrasion and tear resistant plastic with UV inhibitors, Matte finish.
2. Corners: Unspecified
3. Grommet: 3/8" Brass with UV resistant black plastic tie as specified.
4. Dimensions, Lettering and Color: per attached drawings

**Performance:**

1. Average Outdoor Durability: 3-5 years
2. At 100 Degrees F, No Blistering, Color Change Or Other Material Degradation.
3. No Effect When Immersed In Diesel Fuel, Motor Oil, Antifreeze, 2% Detergent, Kerosene, Acetic Acid, or Acetone and Water.
4. Service temperature range: -40 to + 200 degrees F

**Identification and Packaging:**

1. 25 tags shall be packaged in a .004" polyethylene resalable bag with UV resistant black plastic tie specified, they can be loose.
2. Each carton marked with name of manufacturer, PO number, date of manufacture, qty, sample and customers stock code number.

**Approved Manufacturers:** (Artwork Proofs must be on file or submitted before PO approval.)

Stock No.	Stock Description	Fig #
015346	Tag, <b>Equipment Return</b> , Black on Light Blue, Write-On Plastic with UV Black Plastic 7" Tie, 5.75" X 3"	1
015370	Tag, <b>Equipment Issue</b> , Black on Green, Write-On Plastic with UV Black Plastic 7" Tie, 3" X 3"	3
018276	Tag, <b>Cable Reel Issue</b> , Black on Yellow, Write-On Plastic with UV Black Plastic 7" Tie, 5.75" X 3"	4
018277	Tag, <b>Cable Reel Issue Tracking</b> , Black on Yellow, Write-On Plastic with Four Grommets, 6" X 8"	5
017950	Tag, Trench Inspection <b>NOT APPROVED</b> , Black on Red, Write-On Plastic with 14 inch plastic Tie, 7"X4"	6
015368	Tag, Trench Inspection <b>APPROVED</b> , Black on Green, Write-On Plastic with 14 inch plastic Tie, 7"X4"	7



**Tags – Write-On Plastic  
with Black UV Resistant Plastic Ties**

Originator: D. Smith

Date:5/4/2007

Approval: D. smith

Date:2/1/2008

Revision: Revised Equipment Return Tag

Stds Committee Approval:

**Approved**



**Equipment Return**

Equipment # \_\_\_\_\_

**CHECK ALL THAT APPLY**

<input type="checkbox"/> Bad/No Voltage	<input type="checkbox"/> Lightning
<input type="checkbox"/> Physical Damage	<input type="checkbox"/> Corrosion
<input type="checkbox"/> Change Out / Remove Only	<input type="checkbox"/> Oil Leak

**Comments On Back:**  
-----  
Tear Off

Field Loc ID \_\_\_\_\_

WO# \_\_\_\_\_

Date: \_\_\_\_\_ Initials \_\_\_\_\_  
Electric Shop Use \_\_\_\_\_

Stock # \_\_\_\_\_

Equipment # \_\_\_\_\_

Serial # \_\_\_\_\_

PCB Test# \_\_\_\_\_ Results \_\_\_\_\_ ppm

<input type="checkbox"/> Repair	<input type="checkbox"/> Dispose
---------------------------------	----------------------------------

Chelan County PUD Stock #015294

**Item 015346**  
**Figure 1**  
**5.75" X 3"**  
**With 7 inch**  
**Black Plastic Tie**



**Tags – Write-On Plastic  
with Black UV Resistant Plastic Ties**

Originator: D. Smith

Date:5/4/2007

Approval: D. smith

Date:2/1/2008

Revision: Revised Equipment Return Tag

Stds Committee Approval:

**Approved**

**Equipment Issue**

Equipment # \_\_\_\_\_

WO# \_\_\_\_\_

Date: \_\_\_\_\_

Initials \_\_\_\_\_

**Comments On Back:**

Chelan County PUD Stock #015370

**Item 015370**  
**Figure 3**  
**3" X 3"**  
**With 7 inch**  
**Black Plastic Tie**

**Cable Reel Issue**

Stock # \_\_\_\_\_

Reel # \_\_\_\_\_

WO# \_\_\_\_\_

**Comments:**

Printed  
Foremen  
Initials: \_\_\_\_\_ Date \_\_\_\_\_

Chelan County PUD Stock #018276

**Item 018276**  
**Figure 4**  
**5.75" X 3"**  
**With 7 inch**  
**Black Plastic Tie**



**Tags – Write-On Plastic  
with Black UV Resistant Plastic Ties**

Originator: D. Smith      Date: 5/4/2007

Approval: D. Smith      Date: 2/1/2008

Revision: Revised Equipment Return Tag

Stds Committee Approval:  
**Approved**

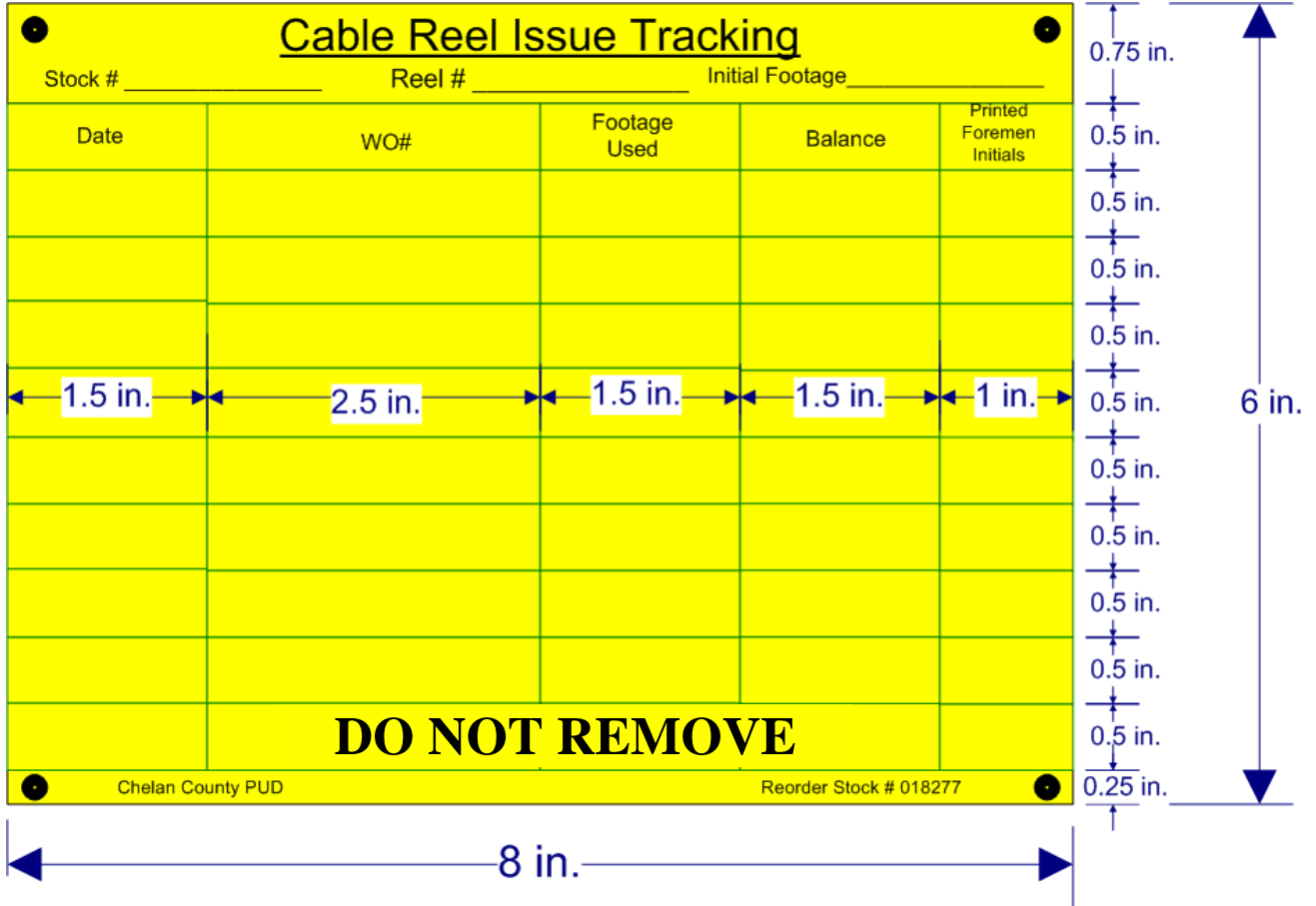

**Item 018277**  
**Figure 5**  
**6" X 8"**  
**With Four**  
**Grommets**



**Tags – Write-On Plastic  
with Black UV Resistant Plastic Ties**

Originator: D. Smith

Date: 5/4/2007

Approval: D. Smith

Date: 2/1/2008

Page 5 of 6

Revision: Revised Equipment Return Tag

Stds Committee Approval:

**Approved**

PUBLIC UTILITY DISTRICT NO. 1 OF CHELAN COUNTY  
**UNDERGROUND DITCH INSPECTION**

SERVICE  
ADDRESS: \_\_\_\_\_

CUSTOMER: \_\_\_\_\_

## Not Approved

Call (509) 661-4325

Employees  
Initials: \_\_\_\_\_ Date: \_\_\_\_\_ Time: \_\_\_\_\_

Not approved because:

- Trench too shallow
- Improper bedding material
- Improper sweep size used (Requirement : 36")
- More than 3-90° bends in conduit run
- Lack of warning tape
- Improper conduit (Requirement: SCH 40 PVC)
- Other: \_\_\_\_\_

---

This inspection is for compliance of P.U.D. standards only. Final inspection must be made by Department of Labor and Industries Electrical Inspection Division.

**NO BUILDING MATERIAL REFUSE IS  
TO BE DISCARDED INTO DITCH.**

Stock #017950

**Item 017950**  
**Figure 6**  
**7" X 4"**  
**With 14 inch**  
**Plastic Tie**





**Tags – Write-On Plastic  
with Black UV Resistant Plastic Ties**

Originator: D. Smith

Date:5/4/2007

Approval: D. smith

Date:2/1/2008

Revision: Revised Equipment Return Tag

Stds Committee Approval:

**Approved**

PUBLIC UTILITY DISTRICT NO. 1 OF CHELAN COUNTY  
UNDERGROUND DITCH INSPECTION

SERVICE ADDRESS: \_\_\_\_\_

CUSTOMER: \_\_\_\_\_

**Approved**

Employees  
Initials: \_\_\_\_\_ Date: \_\_\_\_\_ Time: \_\_\_\_\_

Other: \_\_\_\_\_

\_\_\_\_\_

\_\_\_\_\_

\_\_\_\_\_

\_\_\_\_\_

This inspection is for compliance of P.U.D. standards only. Final inspection must be made by Department of Labor and Industries Electrical Inspection Division.

**NO BUILDING MATERIAL REFUSE IS TO BE DISCARDED INTO DITCH.**

Stock #015368

**Item 015368**  
**Figure 7**  
**7" X 4"**  
**With 14 inch**  
**Plastic Tie**



# CHEMICALS

Originator: DSmith

Date: 7/9/2007

Approval: DSmith

Date: 7/9/2007

Page 1 of 1

Revision: **NEW**

Stds Committee Approval:  
**Approved**



# CHEMICALS





- Lubricant -  
Cable Pulling

Originator: DSMITH

Date: 1/23/2007

Approval: J Mitchell

Date: 06/10/2011

Page 1 of 1

Revision: **NEW**

Stds Committee Approval:

**Approved**



**Application:** Cable pulling lubricant shall be suitable for use as a lubricant to reduce pulling tension on all insulated power cables. Lubricity shall be < 0.15 for PE Jacketed cable on PVC conduit at 200lbs/ft.

**Compatibility:** Lubricant shall be compatible with and not damage polyethylene, PVC, lead, rubber, or neoprene cable insulations, jacket, and semi-conductor shields. Lubricant shall be non-staining, non-toxic, water soluble and nonflammable.

**Calculation Of Quantities:**

When ½ gallon bags are used, the number of packs for a pull is:  $N = 0.003 \times L \times D$

- Where: N = Number of packs required
- L = Length of pull in feet
- D = Nominal I.D. of conduit in inches

The quantity appropriate for a difficult pull may be up to +50% above this average, depending on conduit fill, conduit type and condition, number of bends, and pulling environment.

**Temperature Range:** -20°F - 140°F (Winter Mix)

**Packaging & Marking:** Items shall be suitably packaged to prevent damage. The container shall be convenient for handling or storage. Manufacturer's name or symbol and catalog number shall be on each part or its packaging.

**MSDS:** Each shipment shall include a copy of the current Material Safety Data Sheet.

**Approved Manufacturers:**

PUD IDENTIFICATION		MANUFACTURER CATALOG NUMBER	
Stock Description	Stock No.	American Polywater	Rainbow Technology
Lube, Cable Pulling, Ten ½ Gallon Bags in Bucket, Winter Mix, -20°F to 140°F	046012	WJ-110	
Lube, Cable Pulling, 5 Gal Pail, Winter Mix, -20°F to 140°F	046015	WJ-640	8293



**Pole Setting Foam**

Originator: Randy Kono

Date: 7/7/2008

Approval: Standards

Date: 7/7/2008

Revision: **NEW**

Stds Committee Approval:  
**Approved**



**Application:** A hydrophobic two-part polyurethane, expanding foam designed to rapidly provide intermediate backfill for setting utility poles. It forms a low-density, high-strength foam that can structurally support the pole, and maintain its upright positions. Hardware may be strung after 15 minutes. Serves as a barrier impeding the migration of preservation materials into the surrounding soil and ground water. Displays excellent adhesion to wood and manufactured poles and does not require the use of primers.

**Common Name:** Pole Setting Foam

**Packaging and Marking:** Items shall be suitably packaged to prevent damage. The container shall be convenient for handling and storage. Manufacturer's name or symbol and catalog number shall be on each part or (and) its packaging.

**Approved Manufacturers:**

PUD IDENTIFICATION		MANUFACTURER CATALOG NUMBER
Stock Description	Stock No.	Rainbow Technology
POLE SETTING FOAM, BACK FILL, 2 PART, MIXTURE, COVERAGE, 2 CUBIC FEET	042401	79702

**Notes:** This product has a one-year shelf life.



**Cement - PVC Solvent – All Weather – Clear  
Fast Setting**

Originator: DSMITH

Date: 9/25/06

Approval: DSMITH

Date: 9/25/06

Revision: **NEW**

Stds Committee Approval:  
**9/25/06**



**Application:** Medium-bodied cement for use on Schedule 40 & Schedule 80 PVC pipe and fittings, up to 6" diameter. The cement is supplied with a swab attached to the cap. No primer needed for non-pressure applications. Complies with NEMA and UL specifications. Twenty-four 16 oz cans per carton.

**SETUP TIME (Evaporation Rate):**

Air Temperature	Approximate Setup Time
10°- 30°F	4-5 minutes
30°- 50°F	3-4 minutes
50°- 70°F	1-2 minutes
70°- 90°F	1/2-1 1/2 minutes

**Health & Safety:** The cement is flammable and must not be stored or used near open flame. PVC Solvent is extremely flammable and harmful or fatal if swallowed. The vapor is harmful and may irritate eyes and skin. Adequate ventilation is required when using PVC Solvent. Shelf Life is approximately 3 years.

**Disposal:** Return empty cans to stores for disposal.

**Packaging & Marking:** Items shall be suitably packaged to prevent damage. The container shall be convenient for handling and storage. Manufacturer's name or symbol and catalog number shall be on each part and/or its packaging.

**Approved Manufacturers**

PUD IDENTIFICATION		MANUFACTURER CATALOG NUMBER		
Stock Description	Stock No.	Oatey	Carlon	IPS WELD_ON
Cement - PVC Solvent – All Weather - Clear 10°F to 100°F – FAST SETTING – Pint Can	042210	31132	VC9983	DUIT 413 12086